

HTK135 Series

HTK135 | HTK135C

SG WIA Heavy Duty Boring Machine

Technical Leader

The Heavy Duty Boring Machine HTK135/HTK135C, designed by SGWIA with years of expertise and the latest technology, provides high performance and maximum productivity.

		HTK135	HTK135C
Pallet Size (L×W)	mm(in)	2,000×1,800	2,000×1,800
Max. Load Capacity	kg(lb)	10,000	15,000 [20,000]
Min. Indexing Angle	deg	0.001° / 90° (LOCATING PIN)	
Spindle Quill Dia.	mm(in)	Ø135	
Spindle Taper	-	NT #50	
Spindle Speed	r/min	2,000 [2,000] [2,000]	2,000 [2,000] [2,000] [2,000]
Spindle Power	kW (HP)	22 (30) [26 (35)] [37 (50)]	22 (30) [26 (35)] [37 (50)] [37 (50)]
Spindle Driving Method	-	3 Step Gear	
No. of Tools	EA	40 [60, 90, 120]	40 [60]
Travel (X/Y/Z/W)	mm(in)	3,000/2,000/1,600/700 (118.1"/78.7"/63"/27.6") [4,000/2,500/1,600/700 (157.5"/98.4"/63"/27.6")]	3,000/2,000/1,600/700 (118.1"/78.7"/63"/27.6") [4,000/2,500/2,000/700 (157.5"/98.4"/78.7"/27.6")]
Rapid Traverse Rate	m/min(ipm)	8/8/8/8 (315/315/315/315)	10/10/10/8 (394/394/394/315) [7/10/10/8 (276/394/394/315)]

[] : Option • SIEMENS

- One-piece bed construction for ultra precision (HTK135)
- Movable column structure for high-load, heavy load and heavy duty cutting (HTK 135C)
- X/Y-axis expansion up to 1,000mm (39.4") and 500mm (19.7") respectively
- 3 step gear driven spindle for heavy duty cutting
- Optimal boring processing with W-axis travel of 700mm (27.6")
- Linear scale and rotary scale for ultra precision
- Position Encoder on B-axis for highly precise positioning



HTK135C

HTK135

01 BASIC FEATURES

The Most Advanced Mechanism, Revolutionized Productivity & High Performance

ATC & Magazine

- Tool Shank : BT50
- No. of Tools
HTK135 : 40 [Opt. : 60, 90, 120] EA
HTK135C : 40 [Opt. : 60] EA

NC Rotary Table

- Table Size : 2,000×1,800 mm
- Max. Load Capacity
HTK135 : 10,000 kg (22,046 lb)
HTK135C : 15,000 [20,000] kg
(33,069 lb [44,092 lb])
HTK135C Expand : 20,000 kg (44,092 lb)
- B-axis Built-in Position Encoder
- B-axis Spur Gear (HTK135C Series)

High Precision Spindle

- 3 Step Gear Type Spindle
- Cylindrical Roller Bearings
- 2,000 r/min
- W-axis 700 mm (27.6")

Convenient Maintenance

Oil and Air devices are located in front of the machine for easy repair and maintenance.



INCREASED RIGIDITY, OPTIMUM MACHINING CAPABILITY

HIGH RIGIDITY STRUCTURE

Column Moving Type – HTK135C

The column moving Z-axis enables precise machining of large work and prevents sagging of table when loading or machining. Also, table column separate structure provides high rigidity.

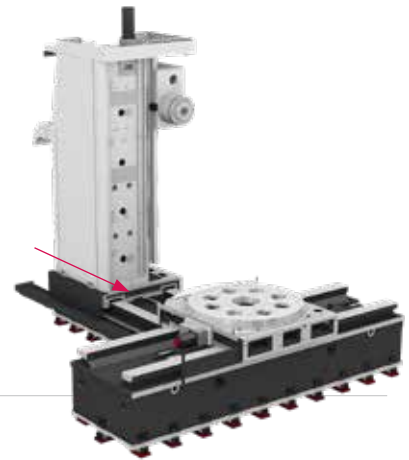

HIGH PRECISION STRUCTURE

Table Moving Type – HTK135

The one-piece bed structure of X/Z-axis helps maintain high accuracy and makes it easier to adjust the machine for better precision.



Fully Protected Slidecover

Slidecover of each axis is fully protected from chips and debris.



Air Semi-Rising Slideway

By applying the Air Semi-Rising Slideways, the load on the X/Z-axis slideway is decreased. Therefore, positioning and repeatability accuracy can be maintained for a long time.

HIGH PRECISION

Linear & Rotary Scales on All Axis

Linear scales on X/Y/Z-axis and rotary scale on B-axis provide High accuracy positioning and enabling precise machining.



02 HIGH PRECISION SPINDLE

Long Lasting, High Accuracy & Excellent Performance

Spindle Specifications

[] : Option

ITEM	Speed r/min	Power (Max./Cont.)	Torque (Max./Cont.)
HTK135	2,000 prm	22/18.5 kW (30/25 HP)	3,114/2,618 N·m
	[2,000 prm]	[26/22 kW (35/30 HP)]	[3,677/3,111 N·m]
	[2,000 prm]	[37/30 kW (50/40 HP)]	[6,824/5,538 N·m]
HTK135C	2,000 prm	22/18.5 kW (30/25 HP)	3,114/2,618 N·m
	[2,000 prm]	[26/22 kW (35/30 HP)]	[3,677/3,111 N·m]
	[2,000 prm]	[37/30 kW (50/40 HP)]	[6,824/5,538 N·m]
	[2,000 prm (SIEMENS)]	[37/31 kW (50/41.6 HP)]	[6,862/5,717 N·m]

HEAVY DUTY CUTTING, 3-STEP GEAR TYPE SPINDLE

SPINDLE

Gear Type Spindle

By using ultra precision cylindrical roller bearings, fast acc/ deceleration of the spindle is achieved. The spindle head is designed to minimize the thermal displacement of the spindle, and with the use of a hydraulic tool locking system the machining stability is increased.

HTK135 series is designed with a 3 step gear driven spindle, providing high torque at low speed and stable machining at high speed.

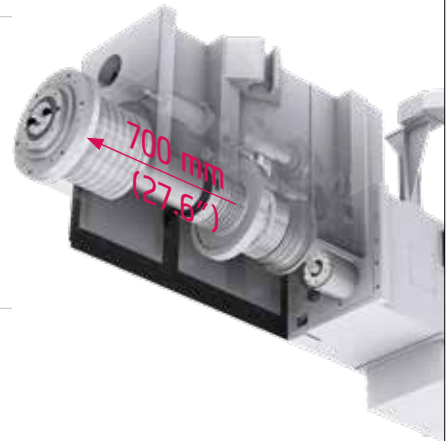

W-Axis Spindle

The W-axis travel of **700mm(27.6")** contributes to the HTK135 series reputation as among the very best boring machines.

Through Spindle Coolant **OPTION**

Through spindle coolant is particularly useful for deep hole drilling and helps increase tool life and decrease cycle time.



SPECIAL HEAD

OPTION

Angle Head (Manual)

Angle head comes with rotary body, which enables machining items that are set perpendicular to the spindle. It is connected to arbors that transfer the torque generated from the main spindle motors.

Angle Head Specifications

- Length : 500 mm (19.6"), 800 mm (31.5") - Angle : 90°, 180°, 270° or or any other customer needs



Facing Head (Manual)

A facing head is attached to the cross section of the spindle for various types of operations: outer facing, inner facing, cylindrical and conical boring and threading etc. It shows excellent performance in machining parts such as flange faces of large valves.



03 MAGAZINE & TABLE

High Productivity Achieved with High Rigidity, Accuracy Machining

ATC & Magazine Specifications

[] : Option

Model	No. of Tools	Max. Tool Dia. (W.T/W.O)	Max. Tool Length	Max. Tool Weight
HTK135	40 [60, 90, 120] EA	Ø125/Ø25 mm (4.9"/1")	600 mm (23.6")	20 [30] kg (44.1 [66.1] lb)
HTK135C	40 [60] EA			

NC Rotary Table Specifications

Model	Table Size (L×W)	Max. Load Capacity	Min. Indexing Angle	B-axis Driven
HTK135	2,000×1,800 mm (78.7"×70.9")	10,000 kg (22,046 lb)	0.001° / 90° (Locating Pin)	Spur Gear
HTK135C		15,000 [20,000] kg (33,069 [44,092] lb)		

❖ HTK135/C : within 300mm (11.8") of the biased weight)

HIGH RIGIDITY, TOOL CHANGE SYSTEM

ATC & MAGAZINE

Magazine

HTK135 holds 40 tools as standard and maximum of 120 tools as an option. Fixed address tool selection method and a special controlling panel increase convenience.

(HTK135C : 40 Tool Standard / 60 Tool Option)



☉ Machine Dimensions According to Magazine Selection (HTK135)

40 Tool	60 Tool	90 Tool	120 Tool
6,900 mm (271.7")	7,300 mm (287.4")	8,275 mm (325.8")	9,250 mm (364.2")

TABLE

NC Rotary Table

High ratio worm gear leads to high precision machining and **built-in position encoder** in B-axis enables precise rotation in 90° and 0.001° which is suitable for machining various shapes. Also it has the largest machining area and best load capacity in its class which enables easier work setting.

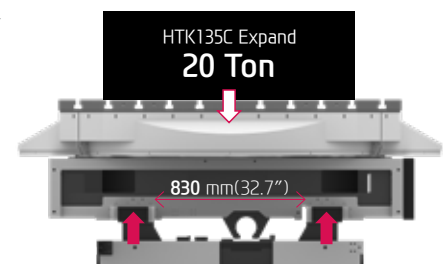

B-AXIS SPUR GEAR

The B-axis is driven by a spur gear to improve productivity, and increase the table positioning speed.

(HTK135C : 2 rpm, HTK135C Expand Option : 1 rpm)

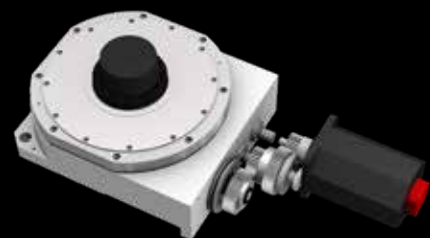

04 USER CONVENIENCE

Various Devices for User Friendly



SHUTTLE TYPE APC OPTION

HTK135C >>



Shuttle Type APC

The HTK135C is equipped with a shuttle type APC as standard. The pallet can be rotated in the loading station for quick and easy load/unload of machined parts. The powerful clamping by clamping plate is suitable for heavy duty cutting.

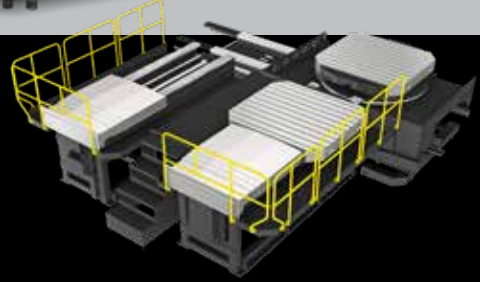

Optional

CHIP DISPOSAL SOLUTION & COOLANT UNIT



Spindle Nozzle & Cutting Air Blow



Gun Coolant



Air Gun



Spindle Cooling Unit

The application of the inverter type, $\pm 0.1^\circ$, enables rapid and effective control of the spindle thermal displacement.

PRECISION & ECO SYSTEM



Linear & Rotary Scale <Std.>



TLM (Laser & Touch) <Opt.>



Touch Sensor <Opt.>

CENTRALIZED CONTROL PANEL

Control Panel

Swing type control panel minimizes unnecessary movement of workers and allows optimal control and handling.

Also, movable MPG which is standard adds even more accessibility to workers.



HTK135



HTK135C



05 MACHINING CAPABILITY

The Best Performance, Powerful Cutting CNC Boring Machine

MACHINING AREA

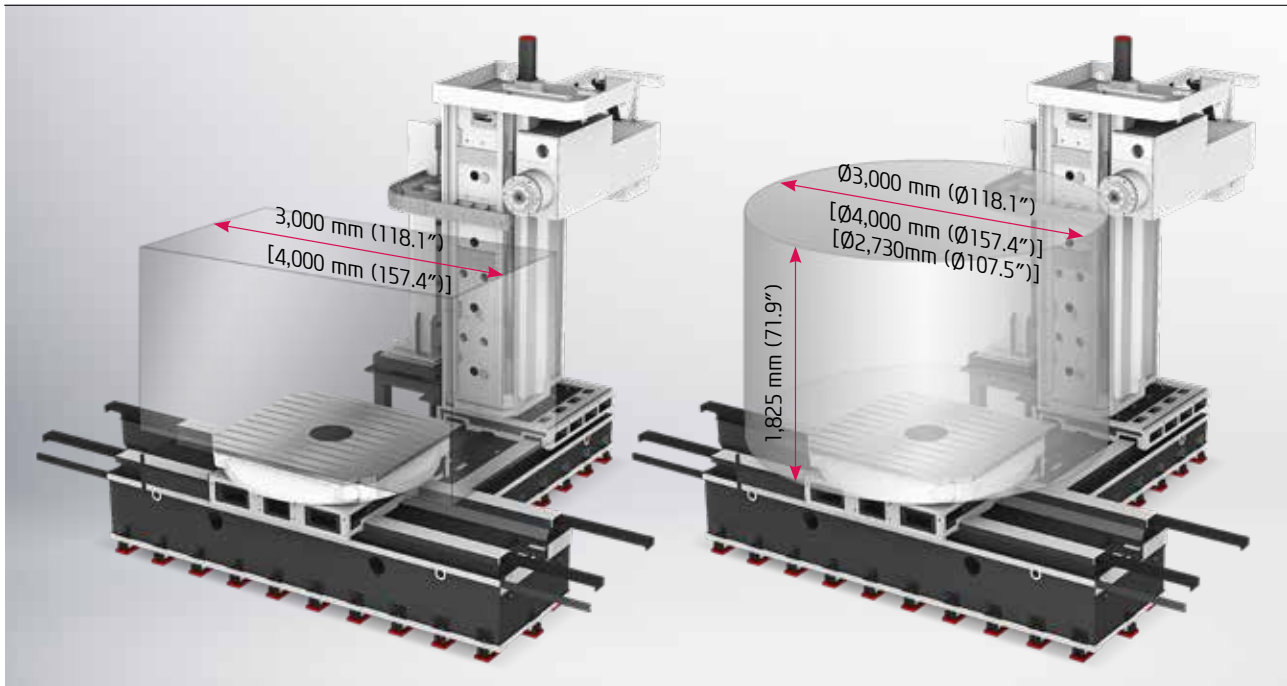

Expansion of Machining Area **OPTION**

HTK135

Unit : mm(in)

ITEM	X-axis	Y-axis	Z-axis	W-axis
Standard	3,000 (118.1")	2,000 (78.7")	1,600 (63")	700 (27.5")
Expansion	4,000 (157.4")	2,500 (98.4")	↑	↑

HTK135C

Unit : mm(in)

ITEM	X-axis	Y-axis	Z-axis	W-axis
Standard	3,000 (118.1")	2,000 (78.7")	1,600 (63")	700 (27.5")
Expansion	4,000 (157.4")	2,500 (98.4")	2,000 (78.7")	↑

Optional Specific Processing Area

Unit : mm(in)

Division	Max. Swing	X-axis Loading Length	Remark
Non Table Around Cover	Ø4,760 (Ø187.4")	4,760 (187.4")	Standard
Standard Table Around Cover	Ø2,940 (Ø115.4")	3,550 (139.8")	Option
Coolant splash cover	Ø2,730 (Ø107.5")	3,550 (139.8")	Option
Expansion Table Around Cover	Ø2,940 (Ø115.4")	4,000 (157.5")	Option

HTK135 / HTK135C

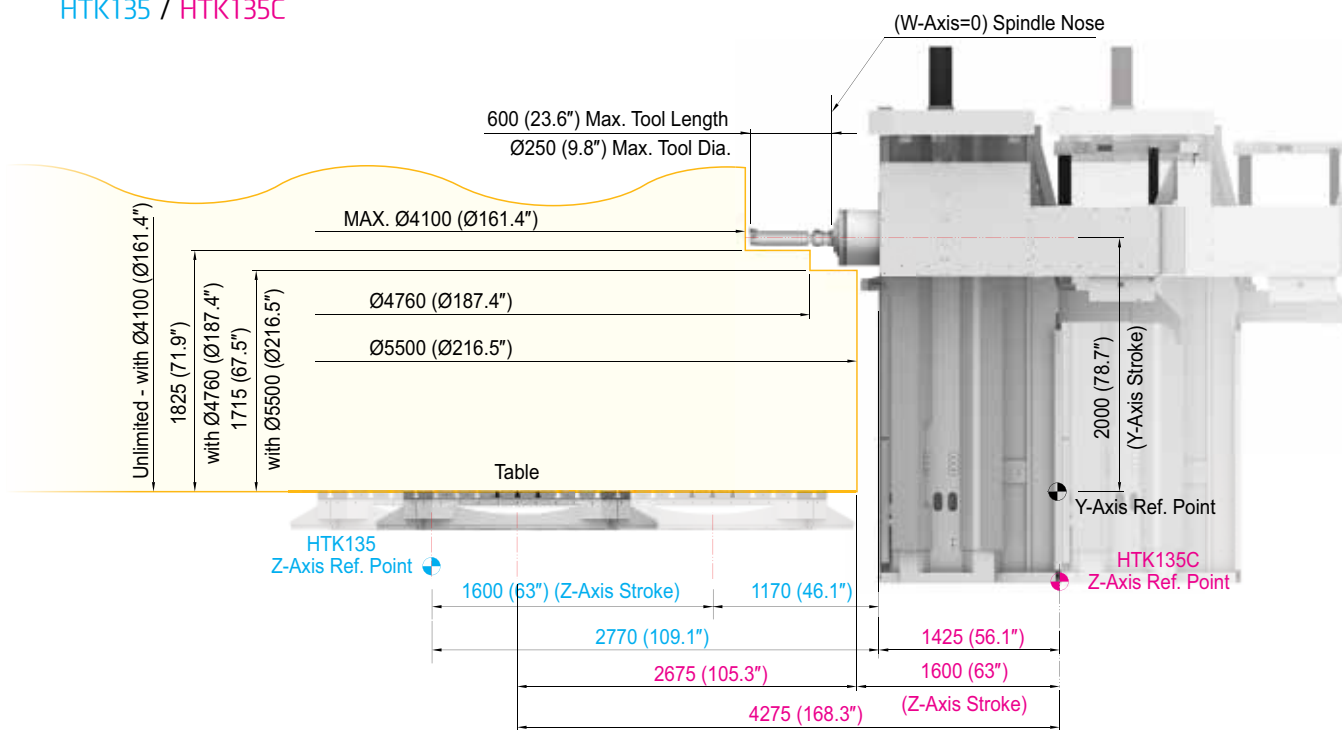

FACE MILLING CAPABILITY

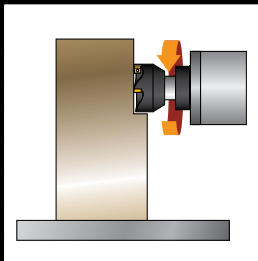

Quill : 0 mm

Speed	450 rpm
Cutting depth	6 mm
Feed	320 mm/min
No. of blades	10 ea
Tool Dia.	160 mm

SS400 (Rolled Structural Steel)

► Excellent Machined Quality

Quill : 300 mm (11.8")

Speed	450 rpm
Cutting depth	5 mm
Feed	320 mm/min
No. of blades	8 ea
Tool Dia.	160 mm

SS400 (Rolled Structural Steel)

► Excellent Machined Quality

❖ The above results might be different by types of processing circumstances.

SPECIFICATIONS

Standard & Optional

Spindle		HTK135	HTK135C
2,000rpm (22kW [30HP])	FANUC	●	●
2,000rpm (26kW [35HP])	FANUC	○	○
2,000rpm (37W [50HP])	FANUC	○	○
2,000rpm (37kW [50HP])	SIEMENS	-	○
Spindle Cooling System		●	●
W Axis Support Sleeve		○	○
ATC			
ATC Extension	40	●	●
	60	○	○
	90	○	☆
	120	○	☆
Tool Shank Type	BT50	●	●
	CAT50	○	○
Heavy Weight Tool	30kg (66lb)	○	○
U-Center	D'andrea	☆	☆
	45°	●	●
Pull Stud	60°	☆	☆
	90°	☆	☆
Facing Head		○	○
Facing Tool Holder (Facing heads when applying)		○	○
Telescopic Tool Holder (Facing heads when applying)		○	○
Angle Head	500mm(19.7")	○	○
	800mm(31.5")	○	○
Auto Indexing Head	730mm(28.7")	☆	☆
Table & Column			
T-Slot Table		●	●
B Axis Table	0.001°	●	●
X Axis Extension	4,000mm(157.4")	○	○
Y Axis Extension	2,500mm(98.4")	○	○
Z Axis Extension	2,000mm(78.7")	-	○
Index Pin (4x90°)		●	●
Table Auto Clamp Device		●	●
Coolant System			
Coolant Device		○	○
Through Spindle Coolant*	20 bar	○	○
	30 bar	-	○
Gun Coolant (Only for Coolant Device)		○	○
Air Gun		○	○
Cutting Air Blow		○	○
Tool Measuring Air Blow (Only for TLM)		○	○
Coolant Chiller (Only for Coolant Device)		☆	☆
Chip Disposal			
Coolant Tank	400 ℓ (105.7 gal)	-	○
	500 ℓ (132 gal)	○	-
Cabin Screw Chip Conveyor		●	●
Cabin Hinge Chip Conveyor	Left	-	○
Chip Conveyor (Hinge/Scraper) -Only for Coolant Device	Left(Front)	○	-
	Left(Rear)	○ (60 Tool : -)	○
	Left(Left)	○	○
Chip Wagon	Standard (180 ℓ [47.5 gal])	○	○
	Swing (200 ℓ [52.8 gal])	○	○
	Large Swing (290 ℓ [76.6 gal])	○	○
	Large Size (330 ℓ [87.2 gal])	○	○
	Customized	☆	☆
ETC			
Tool Box		●	●
CAD&CAM Software	Need for Munsel No.	☆	☆
Customized Color		☆	☆
W Axis Clamp Device		●	●
Y Axis Clamp Device		●	●

● : Standard ○ : Option ☆ : Prior Consultation - : Non applicable

Safety Device		HTK135	HTK135C
Front Full Cover		●	●
Table Around Cover (Only for Thru. Coolant)		○	○
Extension Table Around Cover		☆	☆
Safety Fence		○	○
Electric Device			
Call Light	1 Color : ●	●	●
Call Light & Buzzer	3 Color : ● ● ● B	○	○
Work Light		●	●
Electric Cabinet Light		○	○
Remote MPG		●	●
3 Axis MPG		○	○
Work Counter	Digital	○	○
Total Counter	Digital	○	○
Tool Counter	Digital	○	○
	6 EA	☆	☆
Multi Tool Counter	9 EA	☆	☆
Electric Circuit Breaker		○	○
AVR (Auto Voltage Regulator)		☆	☆
Transformer	50kVA	○	○
	60kVA	○	○
Auto Power Off		○	○
Back up Module for Black out		○	○
Measuring Device			
Air Zero		○	○
TLM (Marposh/Renishaw/Blum)	Touch	○	○
	Laser	○	○
Tool Broken Detective Device		☆	☆
Linear Scale	X/Y/Z Axis	●	●
Rotary Scale	B Axis	●	●
Coolant Level Sensor		☆	☆
Enviornment			
Air Conditioner		○	○
Dehumidifier		○	○
Oil Mist Collector		☆	☆
Oil Skimmer (Only for Chip Conveyor)		○	●
MQL (Minimal Quantity Lubrication)		☆	☆
Fixture & Automation			
Sub O/P		☆	-
Control of Additional Axis	1Axis	☆	☆
	2Axis	-	-
External M Code 4ea		○	○
I/O Extension (In & Out)	16 Contact	☆	☆
	32 Contact	☆	☆
Hyd. Device			
Std. Hyd. Unit	45bar, 200 ℓ (52.8 gal)	●	●
Center Hyd. Supply Device		-	-
Hyd. Unit for Fixture	45bar	☆	☆
	70bar	☆	☆
	100bar	☆	☆
Customized		☆	☆
S/W			
Automatic CAM (HW-ACAM)		-	-
Dialogue Program (HW-DPRO)		○	○
DNC software (HW-eDNC)		○	○
Machine Monitoring System (HW-MMS Cloud)		☆	☆
Machine Monitoring System (Customer Installation : HW-MMS Edge)		☆	☆
Smart Guide-i : FANUC		☆	☆
Smart S/W		☆	☆

Through Spindle Coolant* : Please check the filter types with sales representative.

Specifications are subject to change without notice for improvement. / Please refer to the S/W catalog (iRIS) for details by S/W product.

SPECIFICATIONS

Spindle Output/Torque Diagram

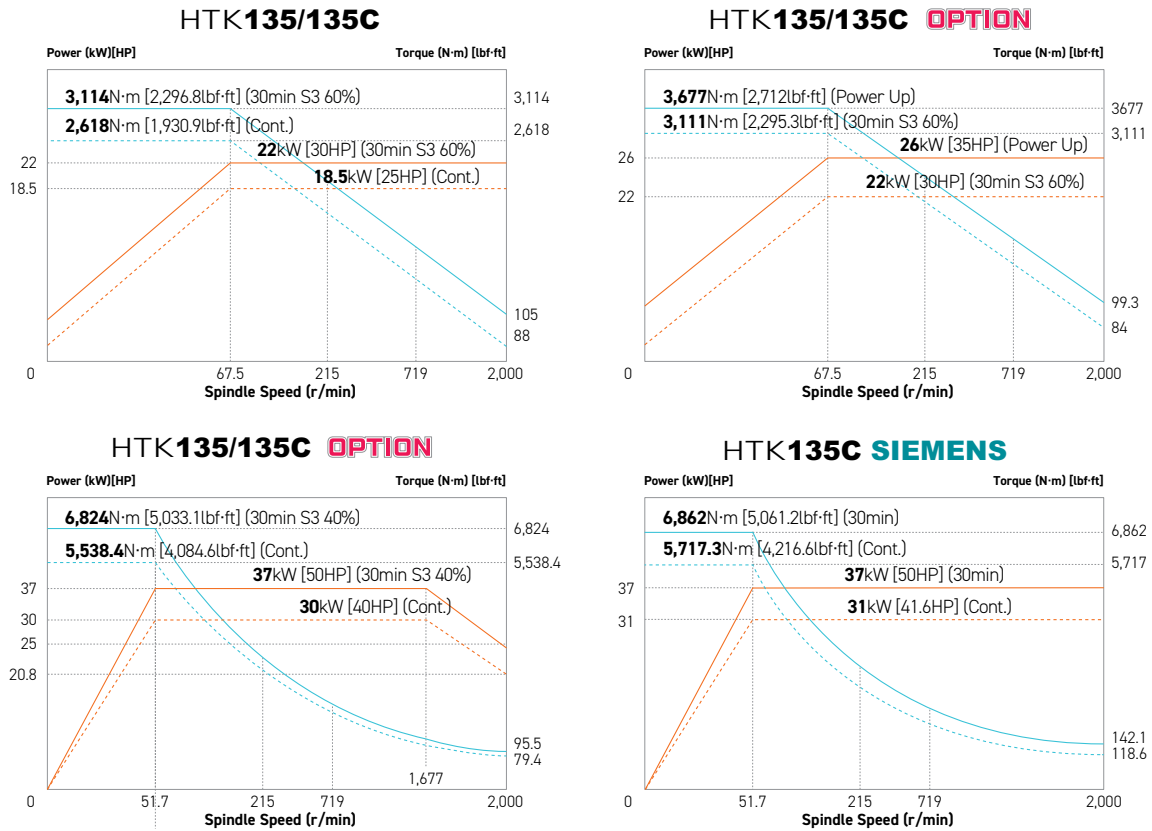

Special Head Specifications

Angle Head	
Length	500 mm (19.7")
Spindle Speed	800 rpm
Speed Ratio	1:1
Lubrication	Grease
Tool Change	Manual
Tool Shank	BT50
Tool Clamping	Bolting (M24)
Max. Tool Weight	20 kg (44.1 lb)
Machine Weight	230 kg (507 lb)

Facing Head	
Radial Transverse	160 mm (6.3")
Max. Rotation	170 rpm
Body Diameter	Ø600 mm (Ø23.6")
ax. Cutting Diameter	Ø920 mm (Ø36.2")
Feed Ratio (Quill:Slide)	1:2
Clamping Bolt	4-M20
T-Slot Distance	190 mm (7.5")
Machine Weight	320 kg (705.5 lb)

SPECIFICATIONS

External Dimensions

unit : mm(in)

HTK135 (Expand Option)

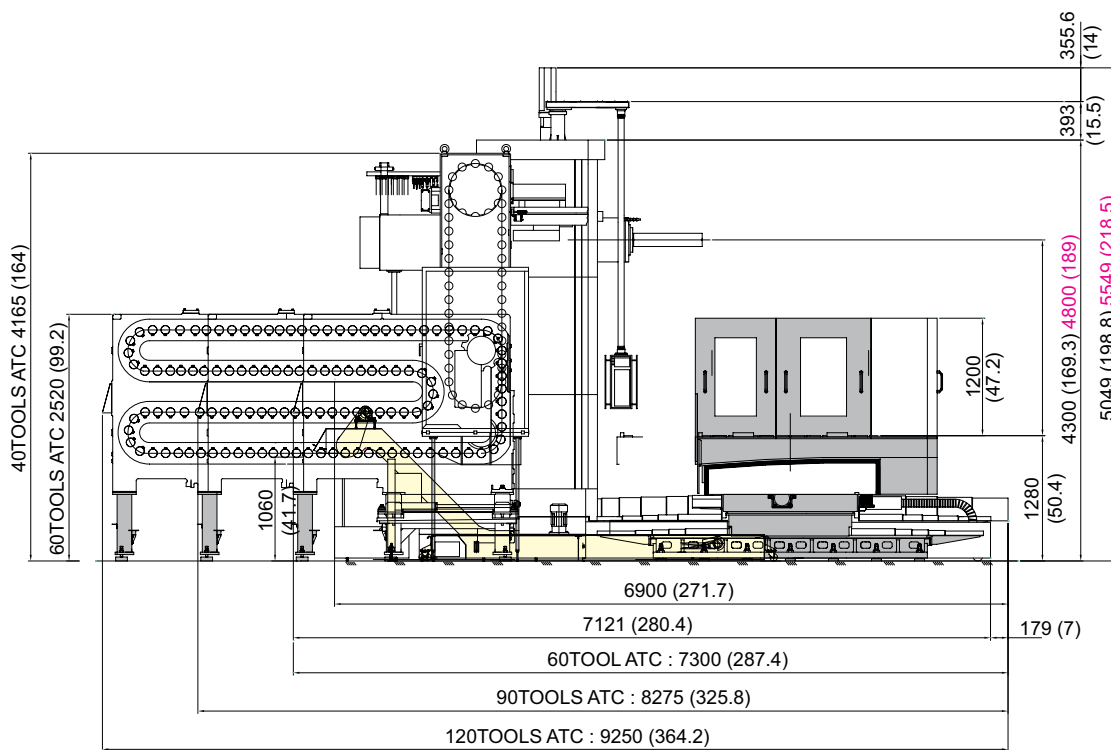
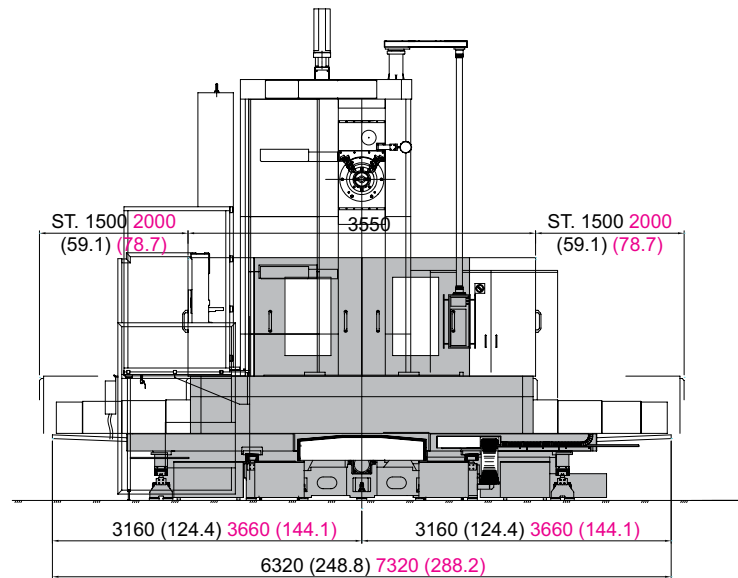

SPECIFICATIONS

External Dimensions

unit : mm(in)

HTK135C (Expand Option)

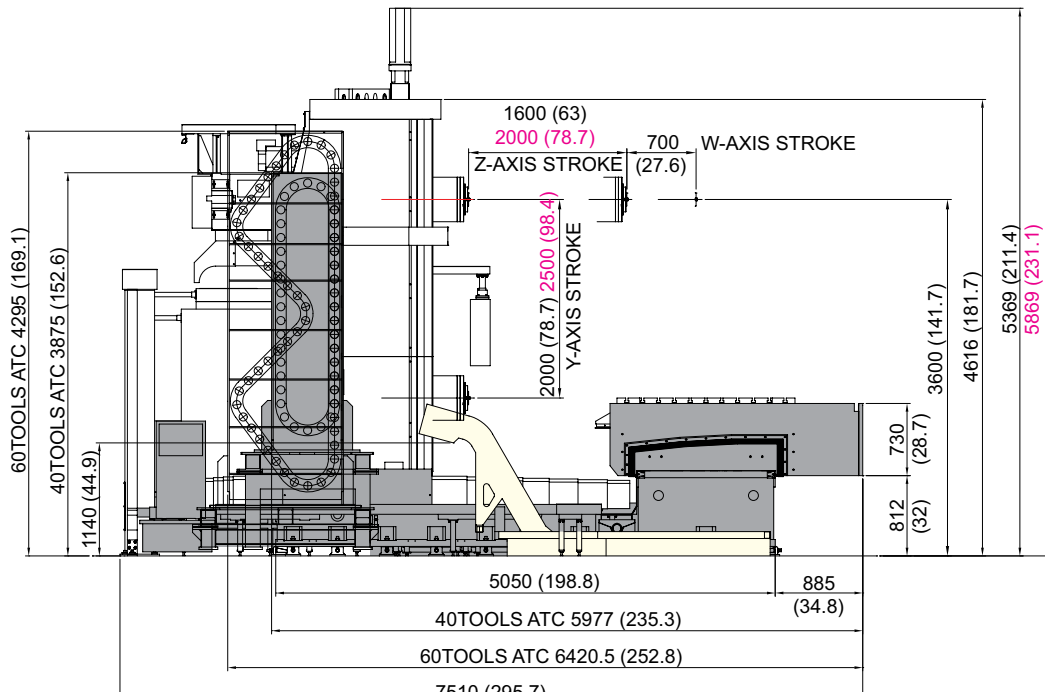
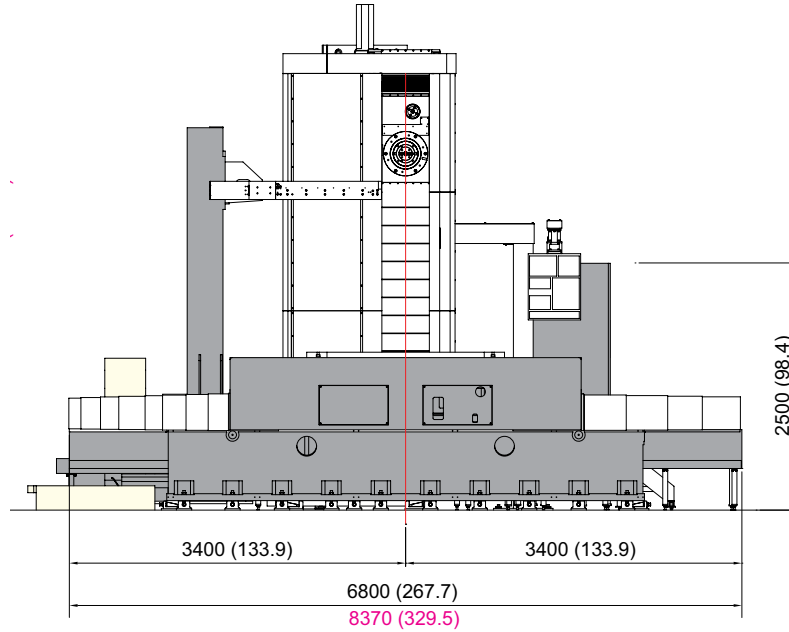

Height when upper hydraulic supply device is attached: 3,845mm (151.4")

SPECIFICATIONS

External Dimensions

unit : mm(in)

HTK135C (APC Type)

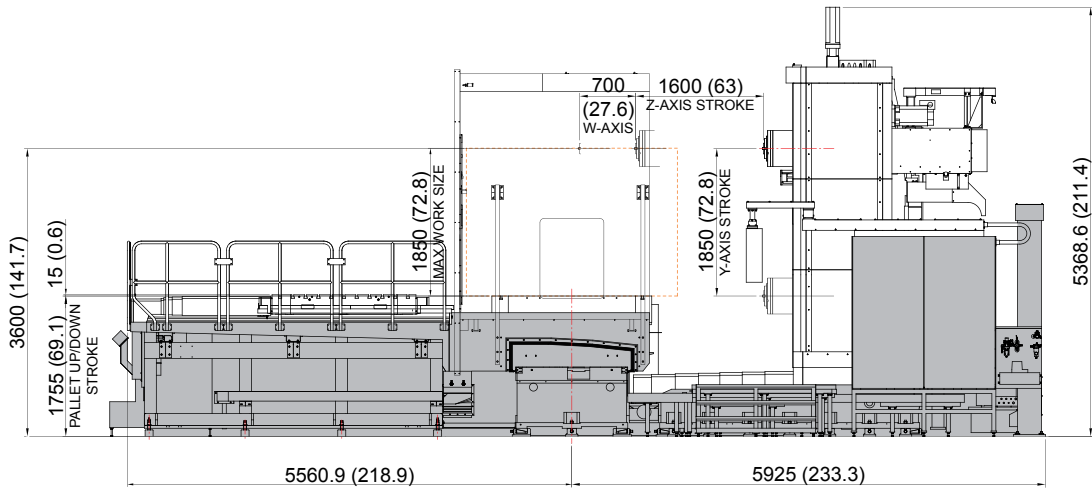
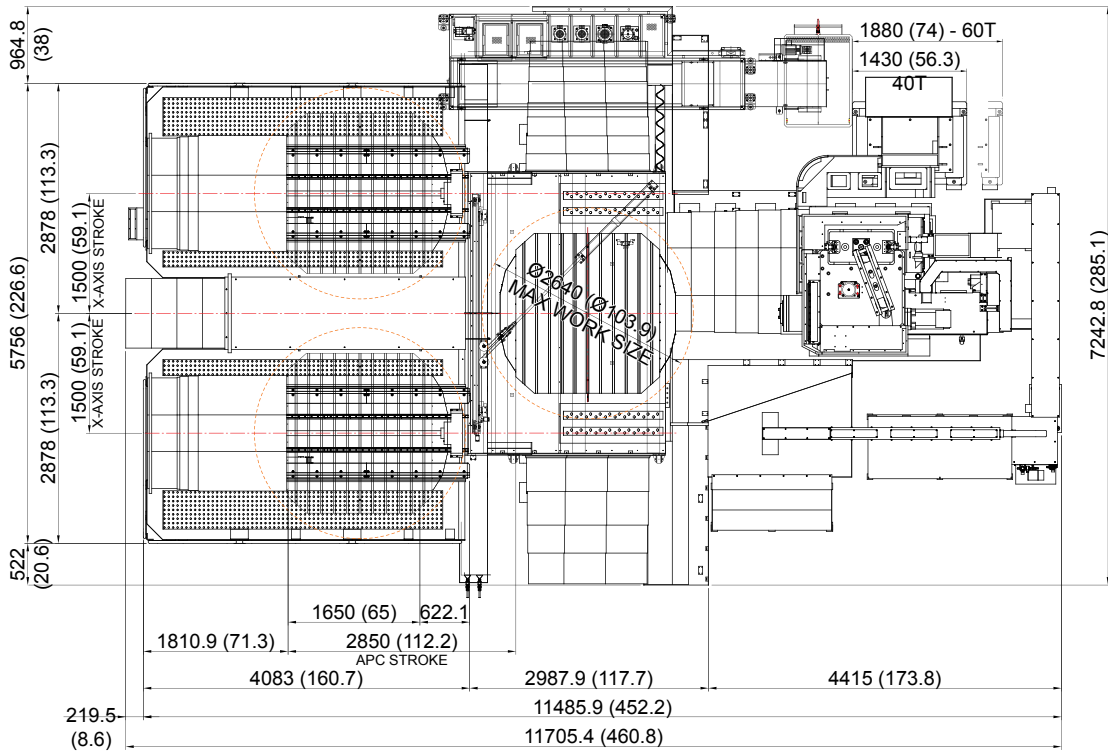

SPECIFICATIONS

Splash Guard

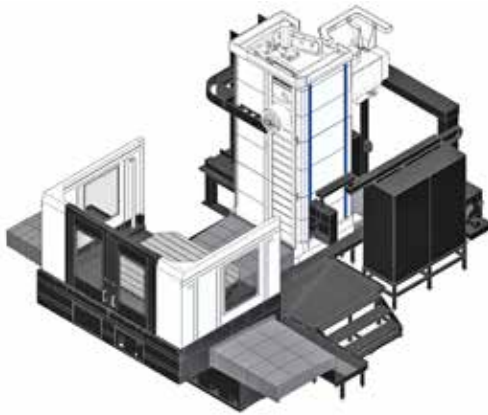

A-Type Table Around Cover

HTK135	○	HTK135C	○
--------	---	---------	---

※ Cannot open or close on HTK135

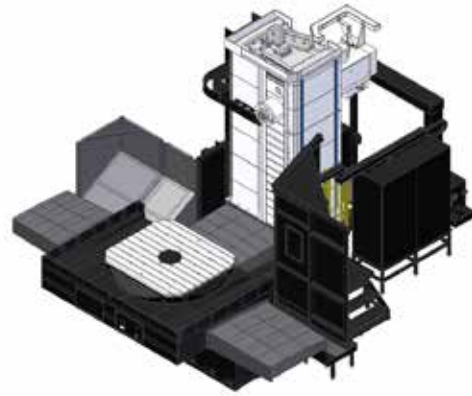

B-Type Coolant Protect Cover

HTK135	-	HTK135C	○
--------	---	---------	---

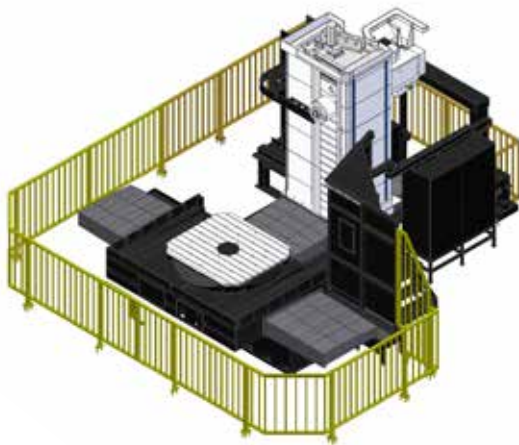

C-Type Safety Fence

HTK135	○	HTK135C	○
--------	---	---------	---

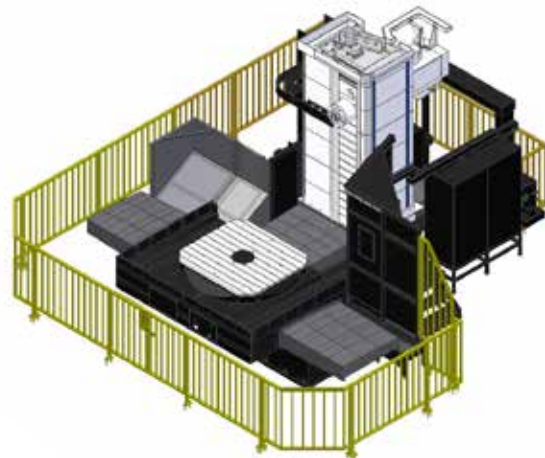

D-Type B+C Type

HTK135	-	HTK135C	○
--------	---	---------	---

Splash guard specifications need to be confirmed with a salesperson.

SPECIFICATIONS

Table Dimensions

unit : mm(in)

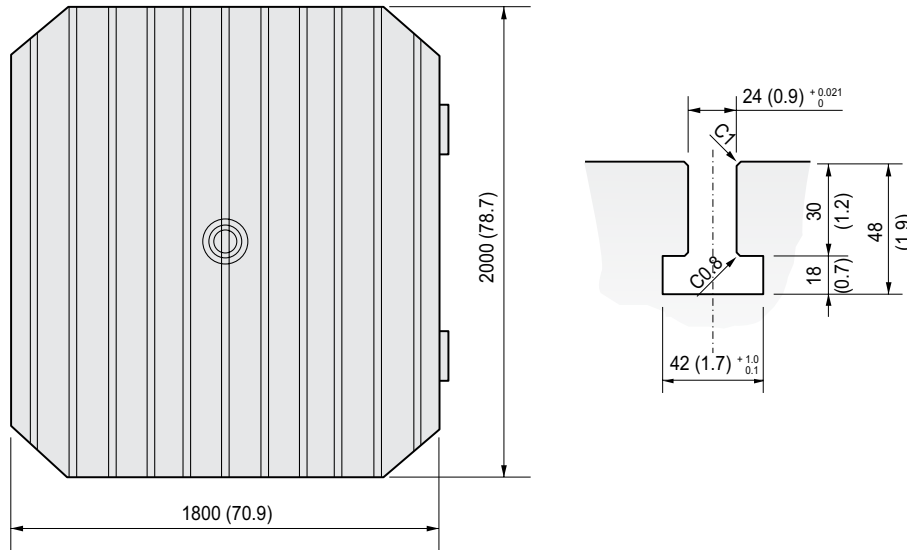

Tool Shank

unit : mm

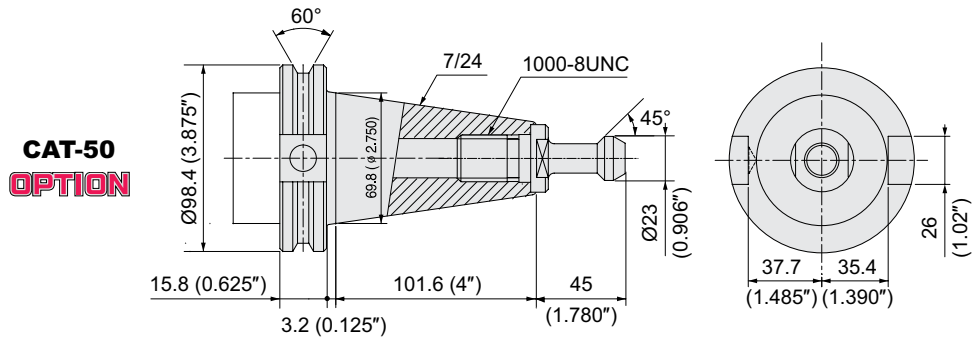
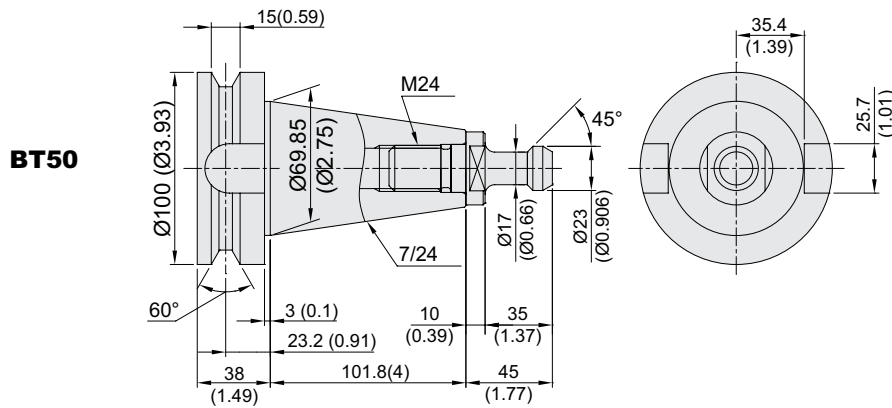

CONTROLLER

Specifications

[] : Option

ITEM			HTK135	HTK135 (Expand Option)	
TABLE	Table Size	mm(in)	2,000×1,800 (78.7"×70.9")		
	Maximum Load Capacity	kgf(lb)	10,000 (22,046)		
	Min. Indexing Angle	deg	0.001° / 90° (LOCATING PIN)		
SPINDLE	Spindle Quill Diameter	mm	Ø135 (5.3")		
	Spindle Taper	-	BT50		
	Spindle Speed (rpm)	r/min	2,000 [2,000] [2,000]		
	Spindle Power (Max./Cont.)	kW(HP)	22/18.5 (30/25) [26/22 (35/30)] [37/30 (50/40)]		
	Spindle Torque(Max./Cont.)	N·m	3,114/2,618 [3,677/3,111] [6,824/5,538]		
	Spindle Driving Method	-	3 STEP GEAR		
FEED	Travel	X-axis	mm(in)	3,000 (118.1")	4,000 (157.5")
		Y-axis	mm(in)	2,000 (78.7")	2,500 (98.4")
		Z-axis	mm(in)	1,600 (63")	
		W-axis	mm(in)	700 (27.6")	
	Distance from Table Surface to SP. Center	mm(in)	0 ~ 2,000(78.7")	0 ~ 2,500(98.4")	
	Distance from Table center to SP. Nose	mm(in)	800 ~ 2,400 (31.5"~94.5")		
	Rapid Traverse Rate (X/Y/Z/W)	m/min(ipm)	8/8/8/8 (315/315/315/315)		
Slide Type	-	BOX GUIDE			
ATC	Number of Tools	EA	40 [60, 90, 120]		
	Tool Shank	-	BT50		
	Max. Tool Dia. (W.T/W.O)	mm(in)	Ø125/Ø250 (4.9"/9.8")		
	Max. Tool Length	mm(in)	600 (23.6")		
	Max. Tool Weight	kg(lb)	20 [30] (44.1 [66.1])		
	Tool Selection Method	-	FIXED ADDRESS		
	Tool Change Time	T-T	sec	30	
C-C		sec	70		
TANK CAPACITY	Coolant Tank	ℓ (gal)	500 (132.1)		
	Lubricating Tank	ℓ (gal)	8.5 (2.2)		
	Hydraulic Tank	ℓ (gal)	200 (52.8)		
POWER SUPPLY	Air Consumption (0.5MPa)	ℓ /min(gal/min)	250 (66)		
	Electric Power Supply	KVA	42		
	Thickness of Power Cable	mm ²	Over 50		
	Voltage	V/Hz	220/60 (200/50*)		
MACHINE	Floor Space (L×W)	mm(in)	6,320×6,900 (248.8"×271.7")	7,320×6,900 (288.2"×271.7")	
	Height	mm(in)	5,049 (198.9")	5,549 (218.4")	
	Weight	kg(lb)	37,200 (82,012)	44,000 (97,003)	
PC	Controller	-	FANUC 31i-B		

◆ within 300mm(11.8") of the biased weight

*) Using 50Hz voltage instead of 60Hz may lower the output of motors. (excluding servo motors and inverter motors)

Specifications are subject to change without notice for improvement.

SPECIFICATIONS

Specifications

[] : Option

ITEM			HTK135C	HTK135C (APC Option)	HTK135C (Expand Option)	
TABLE	Table Size	mm(in)	2,000×1,800 (78.7"×70.9")			
	Maximum Load Capacity	kgf(lb)	❖ 15,000 (33,069) [20,000 (44,092)]	10,000 (2,2046)	❖ 20,000 (44,092)	
	Min. Indexing Angle	deg	0.001° / 90° (LOCATING PIN)			
SPINDLE	Spindle Quill Diameter	mm	Ø135 (5.3")			
	Spindle Taper	-	BT50			
	Spindle Speed (rpm)	r/min	2,000 [2,000] [2,000] [2,000]			
	Spindle Power (Max./Cont.)	kW(HP)	22/18.5 (30/25) [26/22 (35/30)] [37/30 (50/40)] [37/31 (50/41.6)]			
	Spindle Torque(Max./Cont.)	N·m	3,114/2,618 [3,677/3,111] [6,824/5,538] [6,862/5,717]			
	Spindle Driving Method	-	3 STEP GEAR			
	FEED	Travel	X-axis	mm(in)	3,000 (118.1")	
Y-axis			mm(in)	2,000 (78.7")	1,845 (72.6")	2,500 (98.4")
Z-axis			mm(in)	1,600 (63")		2,000 (78.7")
W-axis			mm(in)	700 (27.6")		
Distance from Table Surface to SP. Center		mm(in)	0 ~ 2,000 (78.7")	0 ~ 1,845 (72.6")	0 ~ 2,500 (98.4")	
Distance from Table center to SP. Nose		mm(in)	800 ~ 2,400 (31.5"~94.5")		800 ~ 2,800 (31.5"~110.2")	
Rapid Traverse Rate (X/Y/Z/W)		m/min(ipm)	10/10/10/8 (394/394/394/315)		7/10/10/8 (276/394/394/315)	
Slide Type		-	BOX GUIDE			
ATC	Number of Tools	EA	40 [60]			
	Tool Shank	-	BT50			
	Max. Tool Dia. (W.T/W.O)	mm(in)	Ø125/Ø250 (4.9"/9.8")			
	Max. Tool Length	mm(in)	600 (23.6")			
	Max. Tool Weight	kg(lb)	20 [30] (44.1 [66.1])			
	Tool Selection Method	-	FIXED ADDRESS			
	Tool Change Time	T-T	sec	22.4		30
C-C		sec	33.2		70	
[APC]	No. of Pallet	EA	-	[2]	-	
	Pallet Change Time	sec	-	[250]	-	
	APC Type	-	-	[SHUTTLE]	-	
TANK CAPACITY	Coolant Tank	ℓ (gal)	400 (105.7)			
	Lubricating Tank	ℓ (gal)	8.5 (2.2)			
	Hydraulic Tank	ℓ (gal)	200 (52.8)			
POWER SUPPLY	Air Consumption (0.5MPa)	ℓ/min(gal/min)	250 (66)			
	Electric Power Supply	KVA	42			
	Thickness of Power Cable	mm ²	Over 50			
	Voltage	V/Hz	220/60 (200/50*)			
MACHINE	Floor Space (L×W)	mm(in)	6,880×7,510 (270.9"×295.7")	7,243×11,705 (285.2"×460.8")	8,370×7,910 (329.5"×311.4")	
	Height	mm(in)	5,369 (211.4")	5,367 (211.3")	5,869 (231")	
	Weight	kg(lb)	46,500 (102,515)	65,000 (143,300)	52,000 (114,640)	
NC	Controller	-	FANUC 31i-B [SIEMENS 840D sl]			

❖ within 300mm(11.8") of the biased weight

*) Using 50Hz voltage instead of 60Hz may lower the output of motors. (excluding servo motors and inverter motors)

Specifications are subject to change without notice for improvement.

CONTROLLER

FANUC 31i-B

☆ Needed technical consultation

Controlled axis / Display / Accuracy compensation	
Control axis	5 axis (X, Y, Z, W, B)
Simultaneously controlled axis	4 axis
Least setting Unit	X, Y, Z axis : 0.001 mm (0.0001 inch) B axis : 0.001 deg
Least input increment	X, Y, Z axis : 0.001 mm (0.0001 inch) B axis : 0.001 deg
Inch / Metric conversion	G20 / G21
High response vector control	
Interlock	All axis / Each axis
Machine lock	All axis
Backlash compensation	± 0 ~ 9999 pulses (Rapid traverse / Cutting feed)
Position switch	
LCD / MDI	10.4 inch color LCD
Feedback	Absolute motor feedback
Stored stroke check 1	Over travel
Stored pitch error compensation	
Operation	
Automatic operation (Memory)	
MDI operation	
DNC operation	Needed DNC software / CF card
Program restart	
Wrong operation prevention	
Program check function	Dry run, Program check Z axis Machine lock, Stroke check before move
Single block	
Search function	Program Number / Sequence Number
Interpolation functions	
Pano interpolation	
Positioning	G00
Linear interpolation	G01
Cylindrical interpolation	G02, G03
Exact stop mode	Single : G09, Continuous : G61
Dwell	G04, 0 ~ 9999.9999 sec
Skip	G31
Reference position return	1st reference : G28 2nd reference : G27 Ref. position check : G30
Thread synchronous cutting	G33
Helical interpolation	Circular + Linear interpolation 2 axis(max.)
Feed function / Acc. & Dec. control	
Manual feed	Rapid traverse Jog : 0~5,000mm/min (197 ipm) Manual handle : x1, x10, x100 pulses Reference position return
Cutting feed command	Direct input F code
Feedrate override	0 ~ 200% (10% Unit)
Rapid traverse override	F0% (F1%), F25%, F50%, F100%
Override cancel	
Feed per minute	G94
Feed per revolution	G95
Look-ahead block	40 Block 200 Block (Mold)
Program input	
Tape Code	EIA / ISO
Optional block skip	1 ea
Absolute / Incremental program	G90 / G91
Program stop / end	M00, M01 / M02, M30
Maximum command unit	± 999,999.999 mm (± 99,999.9999 inch)
Plane selection	X-Y : G17 / Z-X : G18 / Y-Z : G19
Workpiece coordinate system	G52, G53, 48 pairs (G54.1 P1 ~ 48)
Manual absolute	Fixed ON
Programmable data input	G10
Sub program call	10 folds nested
Custom macro	#100 ~ #149, #500 ~ #549
G code system	A
Programmable mirror image	G51.1, G50.1
G code preventing buffering	G4.1
Including Chamfering / Corner R	
Canned cycle	G73, G74, G76, G80 ~ G89
Coordinate rotation	G68, G69

Auxiliary function / Spindle speed function	
Auxiliary function	M 4 digit
Level-up M Code	Multi / Bypass M code
Spindle speed command	S 5 digit , Binary output
Spindle override	0% ~ 150% (10% Unit)
Spindle orientation	M19
FSSB high speed rigid tapping	
Tool function / Tool compensation	
Tool function	Max. T 8 digit
Tool life management	256 pairs ☆
Tool offset pairs	99 pairs
Tool nose radius compensation	G40, G41, G42
Tool nose length compensation	G43, G44, G49
Tool offset memory C	Tool length, diameter, abrasion(length, diameter)
Tool length measurement	Z axis Input C
Editing function	
Part program storage size	640m (256KB)
No. of registerable programs	1000 EA
Program protect	
Background editing	
Extended part program editing	Copy, move and change of NC program
Memory card program edit	
Data input / output & Interface	
I/O interface	CF card, USB memory Embedded Ethernet interface
Screen hard copy	
External message	
External key input	
External workpiece number search	
Automatic data backup	
Setting, display and diagnosis	
Self-diagnosis function	
History display	Alarm & Operator message & Operation
Run hour / Parts count display	
Maintenance information	
Actual cutting feedrate display	
Display of spindle speed / T code	
Graphic display	
Operating monitor screen	Spindle / Servo load etc.
Power consumption monitoring	Spindle & Servo
Spindle / Servo setting screen	
Multi language display	Support 20 languages
Display language switching	Selection of 5 optional Languages
LCD Screen Saver	Screen saver
Processing select	Speed/rigidity setting
Option	
Additional optional block skip	9 ea ☆
Fast ethernet	Needed option board
Data server	Needed option board
Protection of data at 8 levels	
Sub Spindle control	
Polar coordinate command	G15, G16
Polar coordinate interpolation	G12.1, G13.1
Cylindrical interpolation	G07.1
One-way positioning	G60
Stored stroke check 2, 3	
Inverse-time feed	G93
Scaling	G50, G51
Manual guide i	Conversational auto program
Handle interrupt	
Manual handle feed	2/3 units
Additional custom macro variables	#100~#199, #500~#999 #100~#199, #500~#999, #98000~#98499
Retraction for rigid tapping	
Tool offset number	Max. 2000 pair ☆
Program storage capacity	512KB ~ 8MB ☆
Program registration number	Max. 4000 ea ☆
Additional work coordinate	Max. 300 pair (G54.1 P1 ~ P300)
AICC II	200 block 400 / 600 / 1000 block ☆

Figures in inch are converted from metric values.

The FANUC controller specifications are subject to change based on the policy of company CNC supplying.

CONTROLLER

SIEMENS 840D SL : HTK135

[] : Option ☆ Needed technical consultation

Controlled axis / Display / Accuracy Compensation	
Control axis	5 axis (X1, Y1, Z1, B1, W)
Simultaneously controlled axis	Max. 4 axis
Least setting Unit	X, Y, Z axis : 0.001 mm (0.0001 inch), B axis : 1 deg
Least input increment	X, Y, Z axis : 0.001 mm (0.0001 inch), B axis : 1 deg
Inch / Metric changeover	G70 (inch) / G71 (metric)
Interlock	All axis / Each axis
Machine lock	All axis
Backlash compensation	
Pitch error compensation	
Feedforward control (Torque control)	
LCD / MDI	19 inch color LCD
Keyboard	QWERTY full keyboard
Stored stroke check	Over travel
Operation	
Automatic operation (Memory)	
MDI operation	
Program restart	
Program check function	Dry run / Program check / Machine lock
Single block	
Block search	Block search
Reposition	
Working area limit	Working area limitations
Interpolation functions	
Positioning	G00
Linear interpolation	G01
Circular interpolation	Circular Interpolation CW (G02) Circular Interpolation CCW (G03)
Exact position stop	Single block exact stop (G09) Exact stop G60 (G601, G602, G603)
Dwell	Dwell (G04)
Reference position return	Return to reference point Return to 2nd reference point
Helical interpolation	
Spline interpolation	Non-uniform rational B splines
Feed function / Acc. & Dec. control	
Manual feed	Rapid traverse Jog Manual handle Reference position return
Cutting Feed command	Direct input F code
Feedrate override	0 ~ 120%
Rapid traverse override	1%, 25%, 50%, 100%
Feed per minute	G94
Feed per revolution	G95
Program input	
ISO correspondence	G291(ISO)/G290 (SIEMENS) (ISO G Code system-A)
Optional block skip	8 ea (0~7)
Program stop / end	G90 / G91
Absolute / Incremental program	M00, M01 / M02, M30
Maximum command unit	± 999,999,999 mm, ± 99,999,9999 inch
Plane selection	X-Y : G17, X-Z : G18, Y-Z : G19 G54 ~ G57, G505~G549
Workpiece coordinate system	G500 (Basic frame - settable zero offset) G53 (Work offset non modal) G153 (basic frame non modal)
Sub program call	16 folds nested
G code preventing buffering	STOPRE
Drilling/Milling cycle	with programing support
User cycle	

Auxiliary function / Spindle speed function	
Auxiliary function	M Code 4 digit
Spindle speed function	S Code 5 digit
Spindle override	0% ~ 120%
Spindle orientation	SPOS
Rigid tapping	
Automatic mode Interchange	Spindle / Axis mode
Constant surface speed control	G96, G97
Spindle speed limitation	LIMS
Tool function / Tool compensation	
Tool function	Tool number & Tool name
Tool life management	
Tools in tool list	600 ea
Cutting Edges in tool list	1,500 ea
Tool radius compensation	ISO (G40, G41, G42)
Geometry / Wear compensation	
Tool management function	
Editing function	
Part program storage size	10MB
External Storage devices	USB
Background editing	
Extended part program editing	Copy, move and change of NC program
Memory card program edit	
Data input / output & Interface	
I/O interface	USB memory interface Embedded Ethernet memory interface
Screenshot	
Setting, display and diagnosis	
Self-diagnosis function	
History display & Operation	Alarm & Operator message & Operation
Run hour / Parts count display	
Actual cutting feedrate display	
Display of spindle speed / T code	
Graphic display	
Operating monitor screen	Spindle / Servo load etc.
Multi language display	Support 7 languages Chinese, English, French, German, Italian, Korean, Spanish
LCD Screen Saver	Screen saver & Motion sensing
Option	
ShopMill	Machining step programming for milling
3D simulation	
Real time simulation	
Compressor (Improving machining quality)	Compcad / Compcurv (Cycle 832)
Look-ahead block	3,000 block (With Mdynamics)
Measurement of tool length	
Built-in PC	Industrial PC (IPC427E)
Multi language display	☆ 20 Support languages : Inquiry need