

KV D Series

KV43D | KV52D | KV60D

SG WIA Column Moving Type Vertical Machining Center

Technical Leader

Column Moving Type Vertical Machining Center with High-speed and large work space

The Vertical Machining Center KV-D Series designed by SG WIA with years of expertise and the latest technology, is a column moving type machining center equipped with Dual Table to maximize productivity.

		KV43D	KV52D	KV60D
Table Size (L×W)	mm(in)	2-660×480 (2-26"×18.9")	2-860×570 (2-33.9"×22.4")	2-950×650 (2-37.4"×25.6")
Max. Load Capacity	kg(lb)	2-300 (2-661)	2-350 (2-772)	2-500 (2-1,102)
Spindle Taper	-	BBT40 [HSK-A63]		
Spindle Speed	r/min	8,000 [8,000 : High Torque] [12,000] [15,000]		
Sp. Power (Max./Cont.)	kW(HP)	18.5/15 (25/20) [15/11 (20/15)] [18.5/15 (25/20)] [18.5/15 (25/20)]		
No. of Tools	EA	42 : Pick-up Type		45 : Pick-up Type
Travel (X/Y/Z)	mm(in)	560/430/570 (22.1"/20.5"/22.4")	760/520/570 (29.5"/20.5"/22.4")	830/600/635 (32.7"/23.6"/25")
Rapid Traverse Rate	m/min	42/42/42		

[] : Option

Dual Table & Column Moving Type Vertical Machining Center

- Dual Tables for enhanced productivity
- High-precision machining by improved spindle quality (Max. 15,000 rpm direct spindle)
- High-speed roller type LM guide in all axis (Rapid Traverse Rate : 42 m/min)
- 42 Tool pickup type magazine application that does not require automatic tool loading device (KV60D : 45 Tool)
- Improved user convenience by applying the latest controller of FANUC

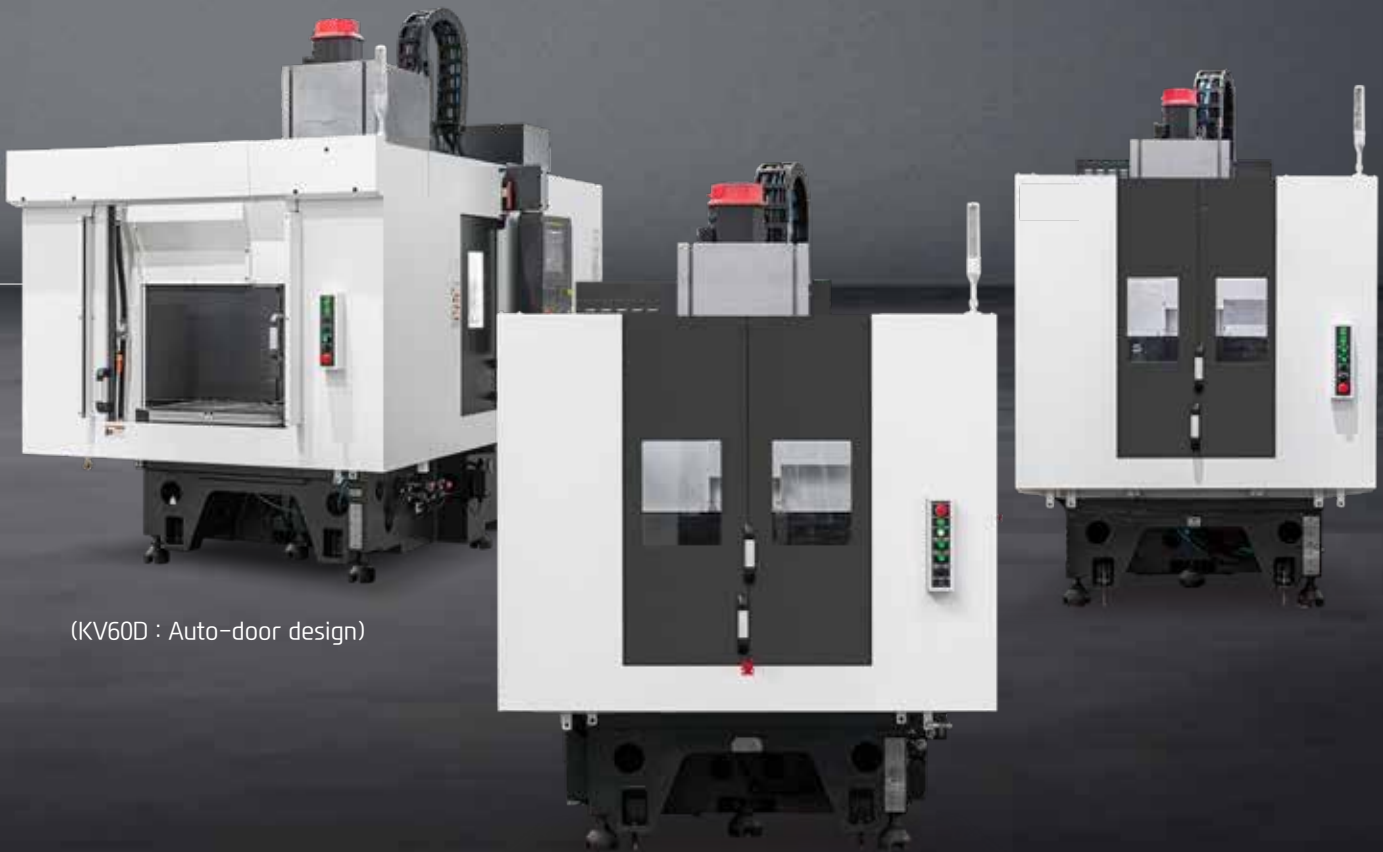

(KV60D : Auto-door design)

01 BASIC STRUCTURE

High Speed & Productivity Column Moving Type Vertical Machining Center

Pick-up Type Magazine

- No. of Tools :
KV43D/52D : 42 EA
KV60D : 45 EA
- Tool Shank : BT40
- Max. Tool Length : 300 mm (11.8")
- Max. Tool Dia. : $\varnothing 125$ ($\varnothing 4.9$ ")
- Max. Tool Weight
BBT 40 : 8kg (17.6 lb)
HSK-A63 : 5kg (11 lb)

High Precision Spindle

- Spindle Type : Direct
8,000/12,000/15,000 rpm
- Spindle Heat Distortion Compensation
Device Standard (Sensorless)

Dual Table

ITEM	Size (X/Y) / Load Capa.
KV43D	2-660×480mm (26"×18.9") 2-300 kg (661 lb)
KV52D	2-860×570 mm (33.9"×22.4") 2-350 kg (772 lb)
KV60D	2-950×650 mm (37.4"×25.6") 2-500 kg (1,102 lb)

KV52D >

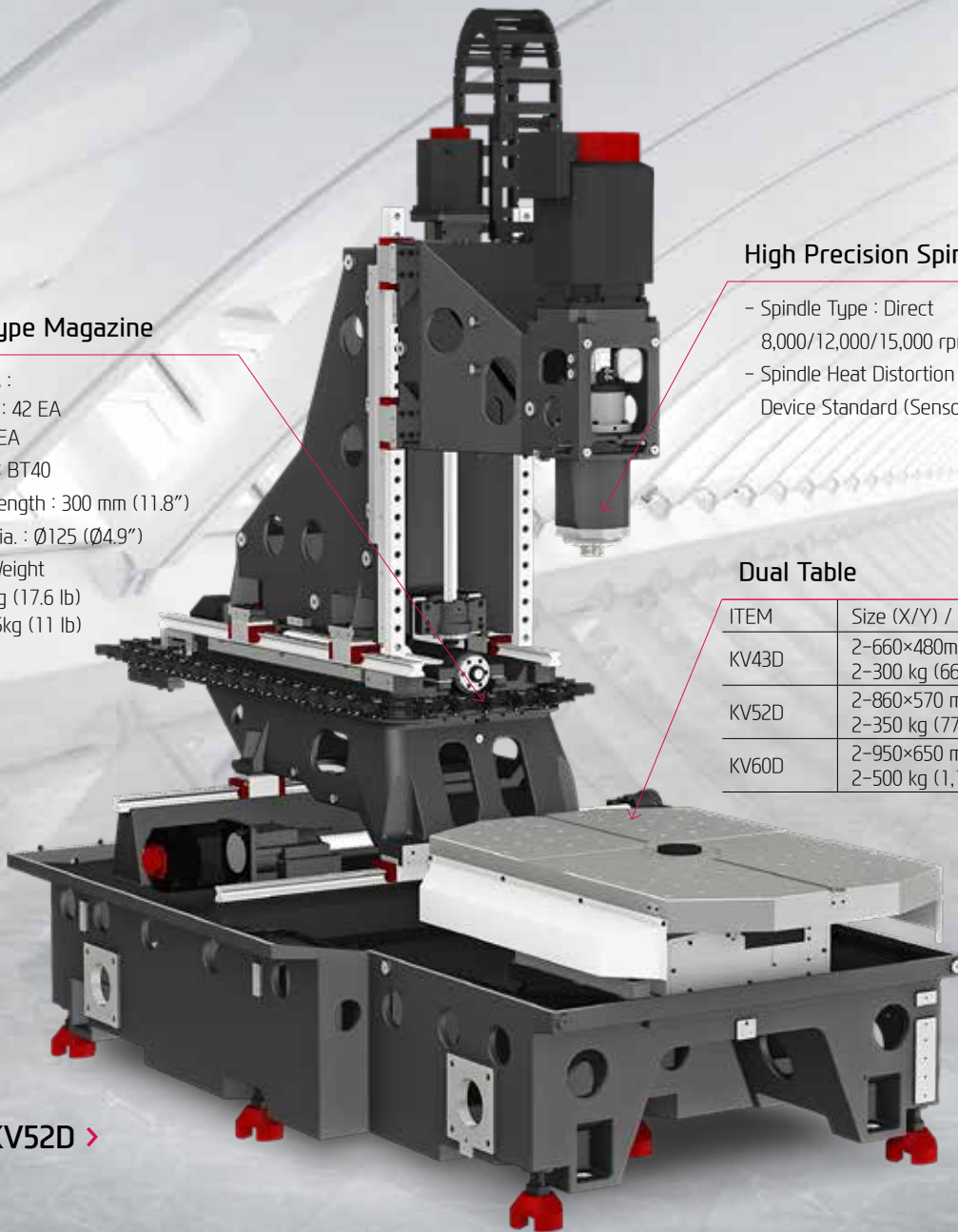

HIGH-PRECISION, SPEED & LARGE WORKING AREA

HIGH-PRECISION STRUCTURE

Optimal Structural Analysis

KV-D series is designed to have optimal structure through SG WIA's unique structural analysis. In particular, enhancement of bed and column's rigidity makes excellent performance even in heavy duty cutting.

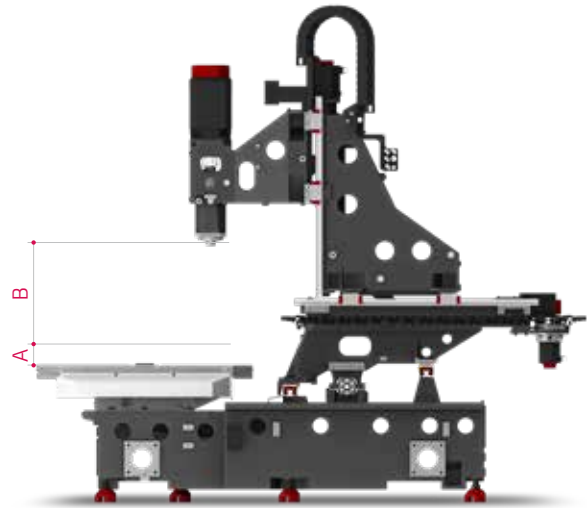

Moving Column

The KV-D Series is designed with a moving column in order to maximize productivity of the incorporated Dual Table. In addition, due to the enlargement of the column's width and symmetrical heat behavior column structure, heat displacement is minimized and machining accuracy is increased.

Z-axis

A (Distance from Table Top to SP. Nose) : 200 mm (7.9")
B (Stroke) : 570 mm (22.4")

Minimized Heat Displacement

To prevent heat displacement of the bed from high temperature coolant, coolant leakage prevention bed cover is applied. This can provide stable machining precision even during long working hours.

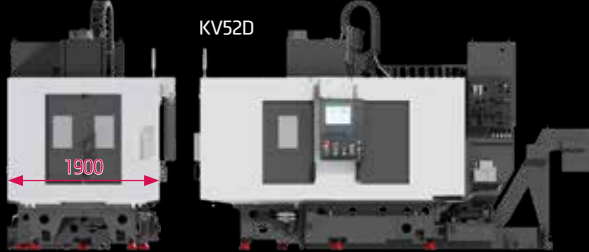

Optimal Structure For Line Automation

- Machine width 1.9m Decreased by 21%
- Rear chip disposal available (Prior model unavailable)

KVSeries

02 HIGH-SPEED FEED

Highest Quality, High-speed Vertical Machining Center



REDUCED NON-CUTTING TIME & IMPROVED FEED PRECISION

GUIDE WAY

High-Speed Roller LM Guideway

By applying an roller LM guide structure with high speed and rigidity, a rapid traverse rate of **42m/min** is achieved based on the all axes.

Ball Screw

The pretensioned ball screw minimizes the expansion and contraction according to the heat and further reinforces the rigidity by the double anchor support method.



● Improved rapid traverse speed

Previous Machine	X-axis	40 m/min	
KV52D	X-axis	42 m/min	5% Improvement
Previous Machine	Y-axis	40 m/min	
KV52D	Y-axis	42 m/min	5% Improvement
Previous Machine	Z-axis	30 m/min	
KV52D	Z-axis	42 m/min	40% Improvement

Travel (X/Y/Z)	Rapid Traverse Rate (X/Y/Z)
KV43D 560/430/570 mm (22.1"/20.5"/22.4")	KV43D 42/42/42 m/min
KV52D 760/520/570 mm (29.5"/20.5"/22.4")	KV52D 42/42/42 m/min
KV60D 830/600/635 mm (32.7"/23.6"/25")	KV60D 42/42/42 m/min

03 HIGH PRECISION SPINDLE

Excellent machining performance with high-precision spindle



Spindle Specifications

[] : Option

Speed r/min	Motor (Max./Cont.)	Torque (Max./Cont.)	Type	Tool Shank
8,000 rpm	18.5/15 kW (25/20 HP)	118/95.5 N·m (87/70.4 lbf·ft)	Direct	BBT40 [HSK-A63]
[8,000 rpm (High-torque)]	[15/11 kW (25/15 HP)]	[286/143 N·m (210.9/105.5 lbf·ft)]		
[12,000 rpm]	[18.5/11 kW (25/15 HP)]	[118/52.5 N·m (87/38.7 lbf·ft)]		
[15,000 rpm]	[18.5/11 kW (25/15 HP)]	[118/52.5 N·m (87/38.7 lbf·ft)]		

HIGH-PERFORMANCE, HIGH-PRECISION SPINDLE

SPINDLE

Direct Type Spindle

The spindle motor is directly connected to the main spindle by a high speed and high precision coupling. Rapid spindle acc/deceleration is performed without backlash. The coupling also minimizes vibration and heat transfer from the motor preventing thermal displacement.

Spindle Cooling **OPTION**

The spindle cooling system minimizes thermal displacement which can happen during lengthy machining operations, and offers continued accuracy based on the thermal stability.

❖ Improved cooling capability with chilling through head frame

Through Spindle Coolant (20/30/70 bar) **OPTION**

Through Spindle Coolant is exceedingly useful when drilling deep holes. It helps increase the lifetime of the tool, while decreasing cycle time.

Prevents oil leakage by applying high-quality rotary joints



Dual Contact Spindle

The Big Plus spindle system (BBT40) provides dual contact between the spindle face and the flange face of the tool holder.

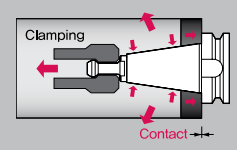

● Increased Maximum Cutting Capacity

Previous Machine	SM45C	368 cc/min
KV52D	SM45C	535 cc/min 45% Improvement

HSK TOOL HOLDER

OPTION

HSK tool holder is utilized for precise positioning with less expansion in the spindle taper during high speed rotation. This ensures an excellent level of precision for die mold machining.



HSK Tool

04 ATC & TABLE

High Productivity Achieved with High Rigidity, Accuracy Machining

ATC Specifications

[] : Option

Model	No. of Tools	Max. Tool Length	Max. Tool Dia. (W.T/W.O)	Tool Shank	Driving Method
KV43D KV52D	42 EA	Ø50 : 300 mm (11.8") Ø125 : 170 mm (6.7")	Ø80/125 mm (Ø3.1"/Ø4.9")	BBT40 [HSK-A63]	Pick-up Type
KV60D	45 EA				

HIGH RIGIDITY, TOOL CHANGE SYSTEM

ATC & MAGAZINE

Pick-up Type Magazine

Automatic tool loading device with unnecessary pick-up type magazine has excellent maintainability.

Chip disposal is enhanced by making the disposal direction going under the tools.

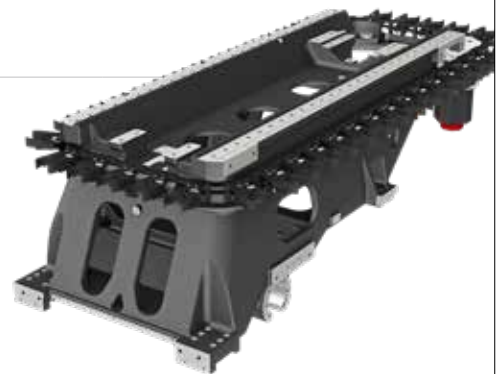

Tool Change Time (C-C)

KV43D : 4.6 sec

KV52D : 4.7 sec

KV60D : 4.8 sec

TABLE

Dual Table

High productivity is achieved by the dual table which enables workers to setup a new workpiece while the machine is processing. Especially, the rotary table is designed for the simpler positioning by the location pin due to the application of hydraulic methods.

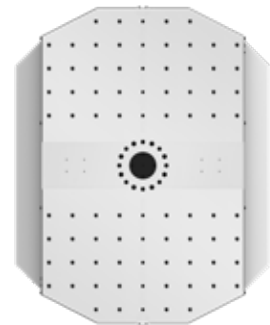

Previous Machine	Change Time	6 sec
------------------	-------------	-------

KV43D	Change Time	5 sec	1 sec Reduction
-------	-------------	-------	-----------------

Previous Machine	Table Size	2-700×500 mm
------------------	------------	--------------

KV52D	Table Size	2-860×570 mm	40% Improvement
-------	------------	--------------	-----------------

Model	Table Size (L×W)	Max. Load Capacity	Change Time
KV43D	2-660×480 mm (26"×18.9")	2-300 kg (2-661 lb)	5 sec
KV52D	2-860×570 mm (33.9"×22.4")	2-350 kg (2-772 lb)	5.5 sec
KV60D	2-930×650 mm (37.4"×25.6")	2-500 kg (2-1,102 lb)	8.3 sec

05 USER CONVENIENCE

Various Devices for User Friendly

CHIP DISPOSAL SOLUTION & COOLANT UNIT



- ❶ Upper part of machining area sealed to prevent chip leakage.
- ❷ Installation taps for oil mist collector & gantry loader applied.
- ❸ Convenient layout with rear disposal chip conveyor design.

High Flexibility in Fixture Installation

Rotary valve for fixture under the table and maintenance space secured
Route for fixture rotary valve hose & wire secured on top of the table
Taps on all sides of the bed for fixture clamp valve installation (No.2, 4)



Std. Coolant (Spindle Nozzle)



Shower Coolant (Opt.)



Gun Coolant (Opt.)



Air Gun (Opt.)

Upper-type Conveyor (Std.)

The upper type chip conveyor is applied as a standard to efficiently remove chips generated during machining. In addition, the 415 liter of large coolant tank provides a seamless machining environment even with large amounts of coolant.

Hinge	Chip Type : Roughing Chip, Long Chip, Chip complex	Material : SS41, SM45C, Cast Steel	Rear Direction
	Highly efficient when disposing a lot of chips. Capable of handling stringy chips..		
Scraper	Chip Type : Finely broken chip blown out	Material : cast Iron, Nonferrous	
	Convenient for shortly cut chips.		
❖ Screw	Chip Type : The lower portion of micro-chips	Material : Steel, Casting	
	Compresses and ejects chips to reduce chip Trouble.		
❖ Drum Filter	Chip Type : Powder, Micro Chip	Material : AL	
	Advantageous in precision, as the chips do not flow in to the coolant nozzle.		

❖ When ordering a screw or drum filter chip conveyor, prior consult with hyundai wia's sales person.

Optional

SG WIA
MACHINE TOOL

CONVENIENT WORK LOADING

Top Cover Open When Door Open

Crane can approach the table when the door is open through the upper side, which allows superior workpiece loading access and maintainability.

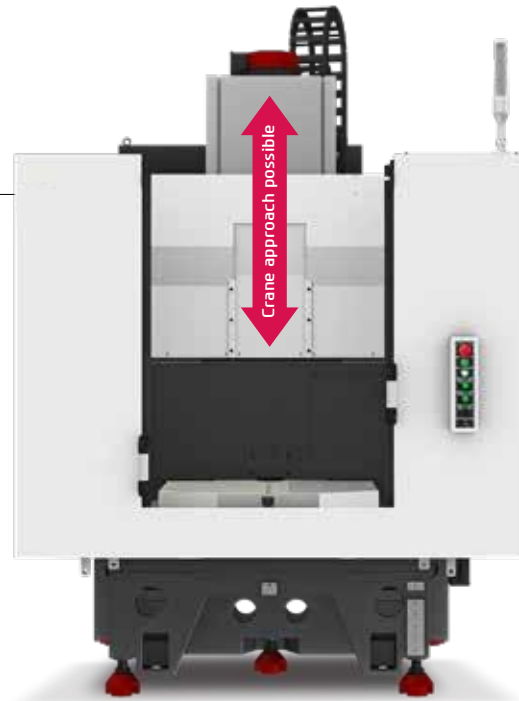

KV-D Series
Vertical Machining Center

12
+
13

PRECISION SYSTEM



Linear Scale

Linear scales increase positioning accuracy and reduce distortion caused by thermal growth, thus ensuring a more accurate finished part



Touch Sensor

Workpiece coordinate values can be set automatically using the optional spindle probe.



TLM (Laser & Touch)

Tool lengths and diameters can be set automatically using the optional tool setter. This can also be used to monitor attrition and detect broken tools.

CREATING VALUE
IN SEAMLESS MOBILITY



CNC ROTARY TABLE & HYDRAULIC SUPPLY UNIT

Various shapes of products can be processed when using CNC Rotary Table. In addition, 100 bar of high pressure hydraulic unit for the fixture increases the tightening power of the teeth.

06 FANUC – Smart Plus

The Compatible All-round Control



15" Touch-type Monitor as a standard

Smart Machine Control	Fast Cycle Time Technology
Conversational Program	Fine Surface Technology
i-HMI	Smart Guide-i
AI Contour Control	Machining-aid Function
Smooth Tolerance Control	AICC-2 (200 blocks)
JERK Control	0.1 μ m command and specify tolerance
Machining Condition Selection	Diminished vibration by controlling acceleration speed
Machining Quality Control Function	Designated machining level based on speed & quality
Part Program Storage	Smooth Tolerance+ integrated support
No. of Registerable Programs	5120M (2MB)
	1000 EA

MMS (Machine Monitoring System)



MMS Cloud

A cloud server-based equipment monitoring system for collecting and analyzing facility operation data.

Manufacturing big data solution with design, manufacturing, and intelligence technology of SG-WIA
(Big data collection/Analysis/Visualization)

SMART CNC (FANUC Smart Plus)

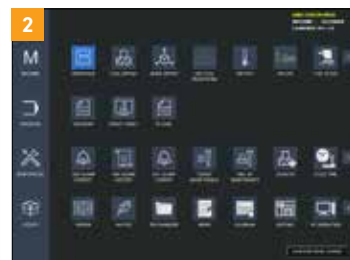

1. Dialogue Program (Smart Guide-i)

This software offers the maximum user convenience through dialogue manipulation from setup to processing. This includes writing processing programs and simulation checks.

2. LAUNCHER

This software offers shortcuts for quick access to specialized features and frequently used features.

SPECIFICATIONS

Standard & Optional

● : Standard ○ : Option ☆ : Prior Consultation - : Non Applicable

Spindle		KV43D	KV52D	KV60D
8,000rpm (18.5kW)	Direct	●	●	●
8,000rpm (15kW)	Direct (High Torque)	○	○	○
12,000rpm (18.5kW)	Direct	○	○	○
15,000rpm (18.5kW)	Direct	○	○	○
Spindle Cooling System	8,000rpm	○	○	○
	12,000/15,000rpm	●	●	●
ATC				
ATC Extension	42	●	●	-
	45	-	-	●
ATC Type	Pick-up	●	●	●
Tool Shank Type	BBT40-8kg (17.6 lb)	●	●	●
	HSK-A63-5kg (11 lb)	○	○	○
U-Center	D'andrea	-	-	-
Pull Stud	45°	●	●	●
Table & Column				
APC	Rotary Turn	●	●	●
Tap Type Table	mm Type	●	●	●
	inch Type	○	○	○
T-Slot Table		○	○	○
NCRotary Table		☆	☆	☆
Coolant System				
Std. Coolant (Main Spindle Nozzle)		●	●	●
* Through Spindle Coolant	20bar	○	○	○
	30bar	○	○	○
	70bar	○	○	○
Top Cover (Machining Room Upper)		●	●	●
Shower Coolant		○	○	○
Gun Coolant		○	○	○
Air Gun		○	○	○
Cutting Air Blow		○	○	○
Tool Measuring Air Blow (Only for TLM)		○	○	○
Air Blow for Automation		☆	☆	☆
Thru MQL Device (Without MQL)		☆	☆	☆
Coolant Chiller (Sub Tank)		☆	☆	☆
Power Coolant System (For Automation)		☆	☆	☆
Chip Disposal				
Coolant Tank	415 ℓ (109.6 gal)	●	●	●
Chip Conveyor (Hinge/Scraper)	Rear(Rear)	○	○	○
	Right(Rear)	○	○	○
Short Type Chip Conveyor (Hinge)+Coolant Tank+Shower Coolant	Rear(Rear)	☆	☆	☆
Special Chip Conveyor (Drum Filter)		☆	☆	☆
Chip Wagon	Standard (180 ℓ [47.5 gal])	○	○	○
	Swing (200 ℓ [52.8 gal])	○	○	○
	Large Swing (290 ℓ [76.6 gal])	○	○	○
	Large Size (330 ℓ [87.2 gal])	○	○	○
	Customized	☆	☆	☆
S/W				
Dialogue Program (HW-DPRO)		○	○	○
DNC software (HW-eDNC)		○	○	○
Machine Monitoring System (HW-MMS Cloud)		☆	☆	☆
Smart Guide-i : FANUC		●	●	●
Smart S/W		☆	☆	☆

Electric Device		KV43D	KV52D	KV60D
Call Light	1 Color : ●	●	●	●
Call Light & Buzzer	3 Color : ● ● ● B	○	○	○
Electric Cabinet Light		○	○	○
Remote MPG		●	●	●
3 Axis MPG		○	○	○
Work Counter	Digital	○	○	○
Total Counter	Digital	○	○	○
Tool Counter	Digital	○	○	○
Multi Tool Counter	Digital	☆	☆	☆
Electric Circuit Breaker		○	○	○
Transformer	40KVA	○	○	○
Auto Power Off		○	○	○
Back up Module for Black out		○	○	○
Measuring Device				
Air Zero	TACO	☆	☆	☆
	SMC	☆	☆	☆
Work Measuring Device		○	○	○
TLM (Marposs/Renishaw/Blum)	Touch	○	○	○
Tool Broken Detective Device	Laser	○	○	○
Linear Scale	X/Y/Z Axis	○	○	○
Coolant Level Sensor (Only for Chip Conveyor, Bladder Type)		☆	☆	☆
Environment				
Air Conditioner		○	○	○
Oil Mist Collector		☆	☆	☆
Oil Skimmer (Only for Chip Conveyor)		○	○	○
MQL (Minimal Quantity Lubrication)		☆	☆	☆
Fixture & Automation				
Auto Door		○	○	○
Sub O/P		☆	☆	☆
NC Rotary Table/F	Single	☆	☆	☆
	Channel	☆	☆	☆
Control of Additional Axis	1Axis	☆	☆	☆
	2Axis	☆	☆	☆
External M Code 4ea		○	○	○
Automation Interface		☆	☆	☆
I/O Extension (In & Out)	16 Contact	☆	☆	☆
	32 Contact	☆	☆	☆
Hyd. Device				
Std. Hyd. Unit	45bar/50 ℓ [13.2 gal]	○	○	○
	2x3 (6 Port)	○	○	○
	2x5 (10 Port)	○	○	○
Center Hyd. Supply Device		○	○	○
ETC				
Tool Box		●	●	●
Customized Color	Need for Munsel No.	☆	☆	☆
CAD&CAM Software		☆	☆	☆

Through Spindle Coolant* : Please check the filter types with sales representative.

Specifications are subject to change without notice for improvement. / Please refer to the S/W catalog (iRIS) for details by S/W product.

SPECIFICATIONS

Spindle Output/Torque Diagram

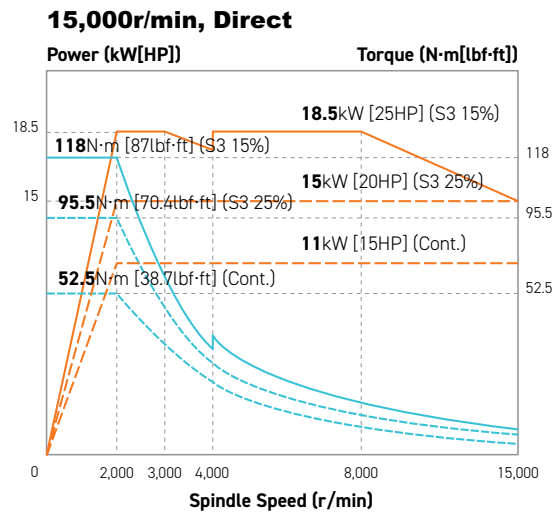
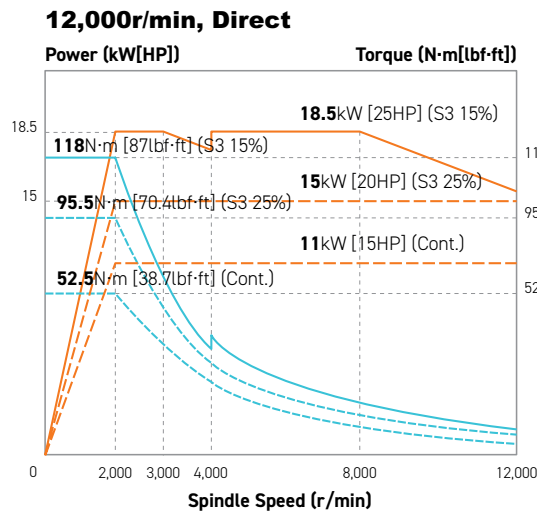
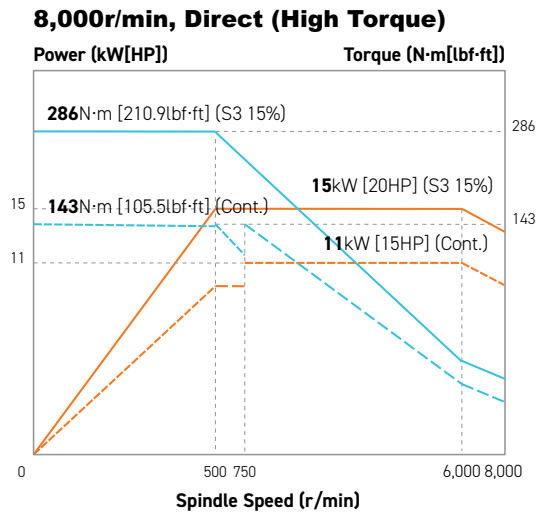
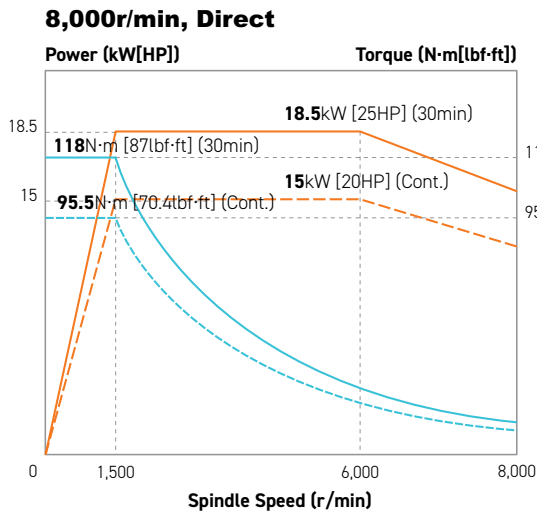

SPECIFICATIONS

External Dimensions

unit : mm(in)

KV43D (Rear Chip Conveyor : Standard)

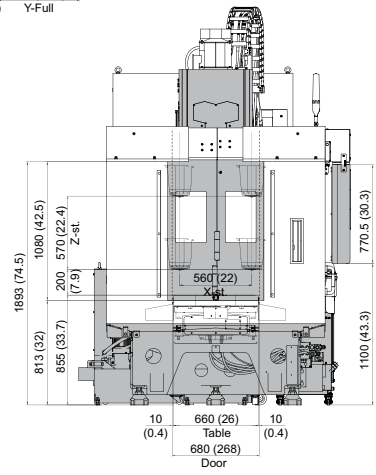
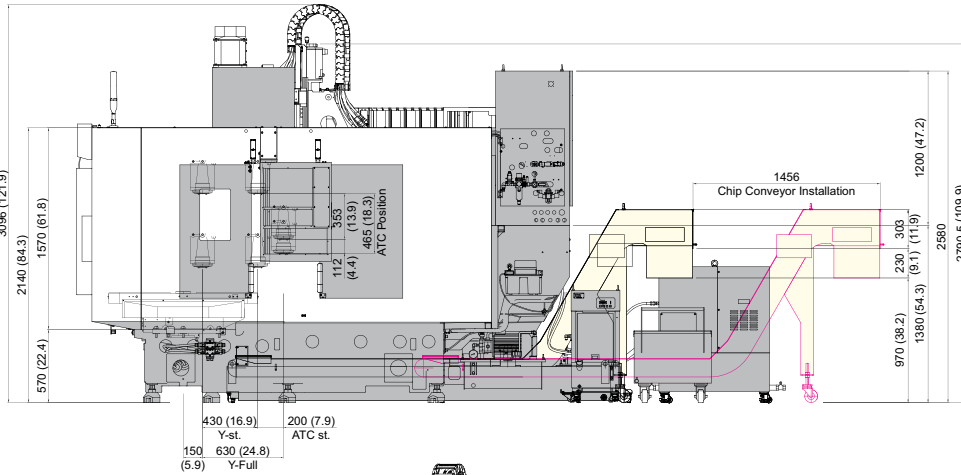
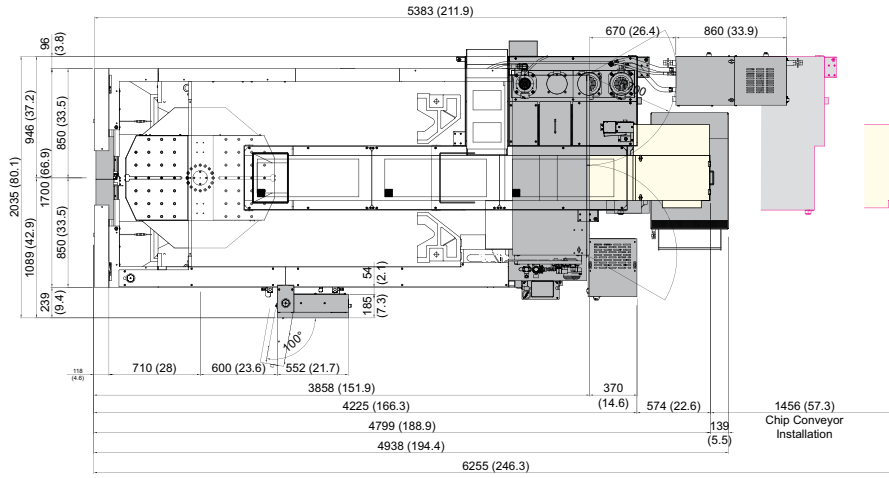

SPECIFICATIONS

External Dimensions

unit : mm(in)

KV43D (Rear Chip Conveyor : Short Type)

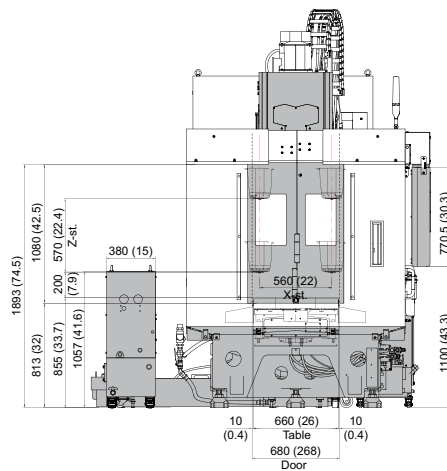
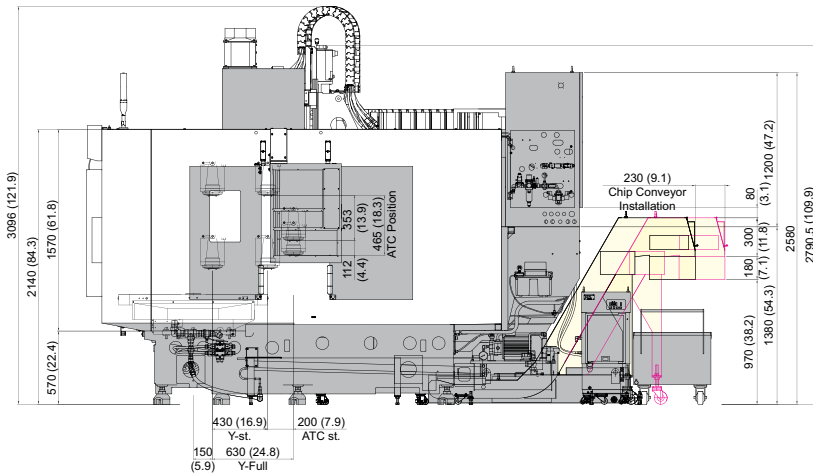
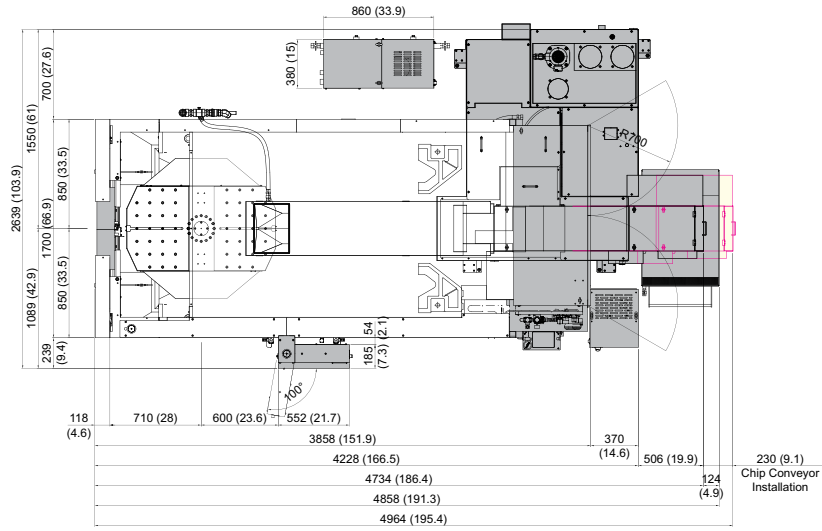

SPECIFICATIONS

External Dimensions

unit : mm(in)

KV52D (Rear Chip Conveyor : Standard)

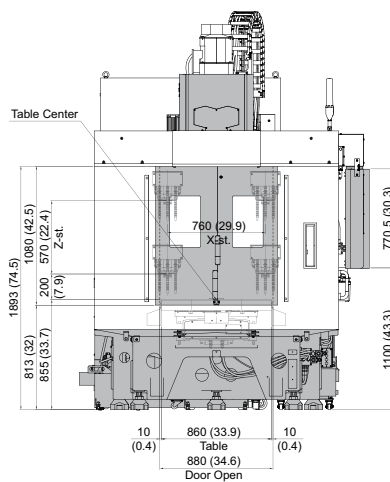
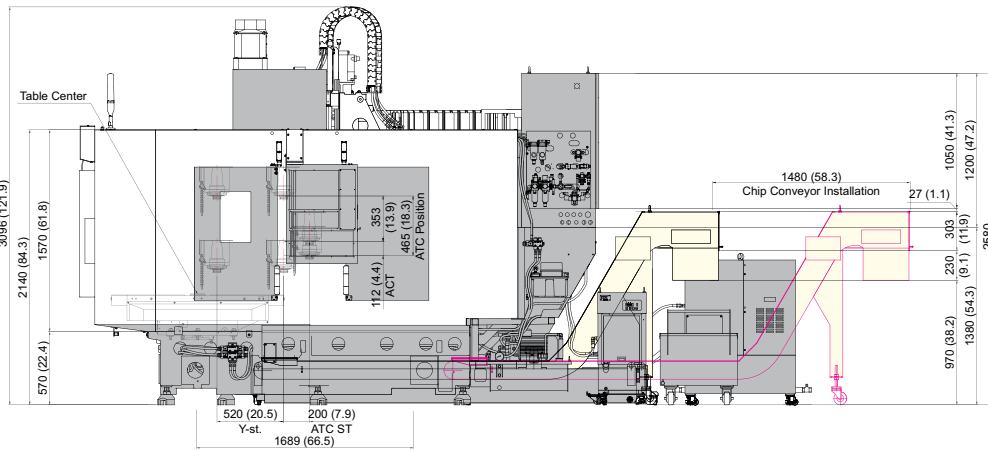
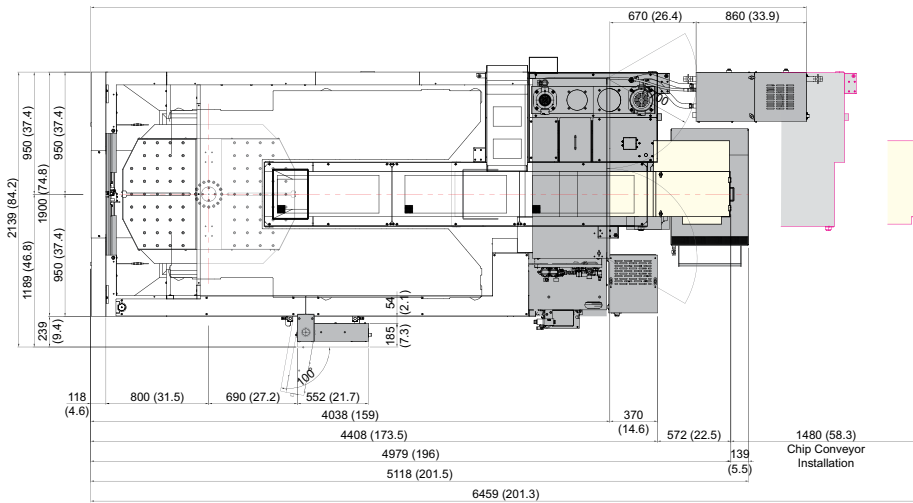

SPECIFICATIONS

External Dimensions

unit : mm(in)

KV52D (Right Side Chip Conveyor)

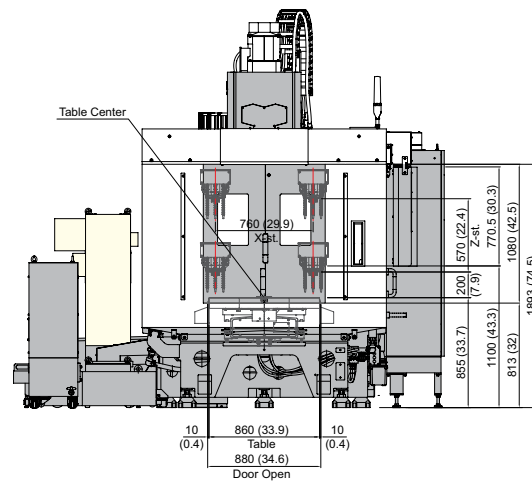
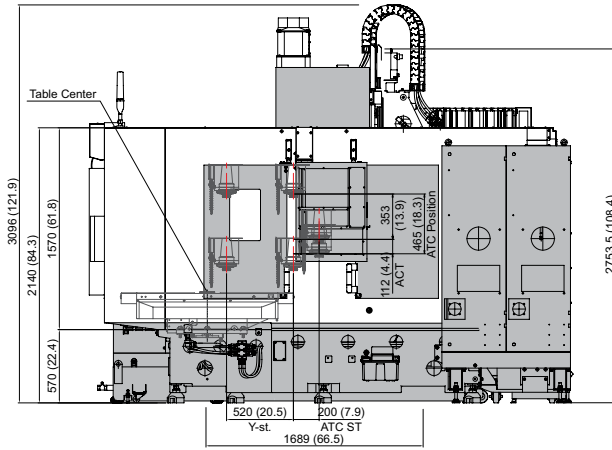
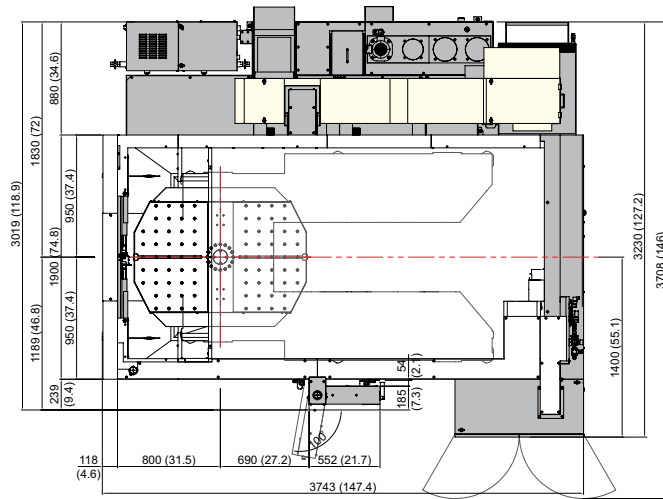

SPECIFICATIONS

External Dimensions

unit : mm(in)

KV52D (Rear Chip Conveyor : Short Type)

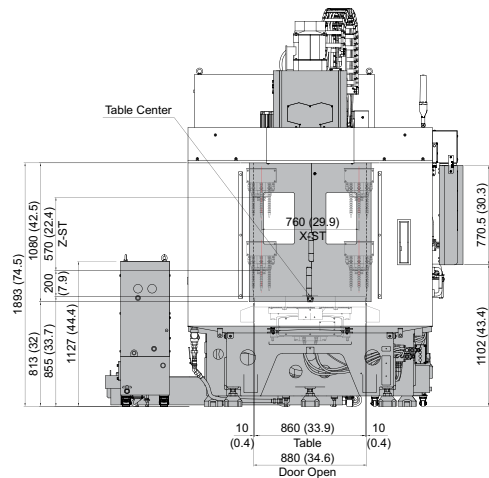
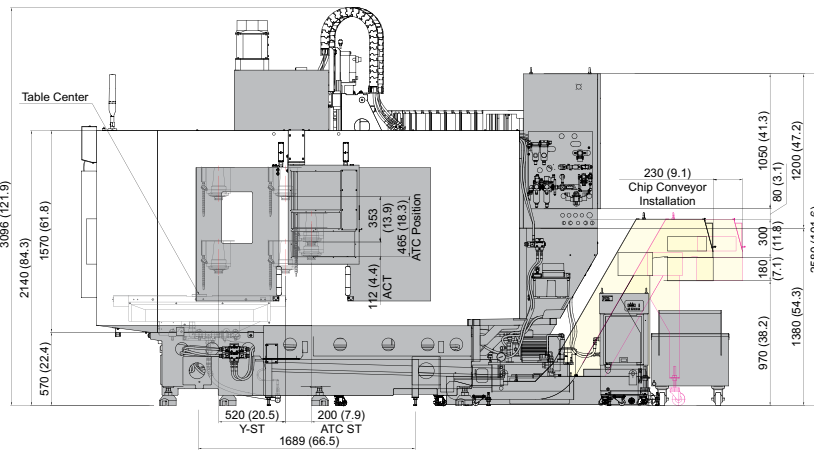
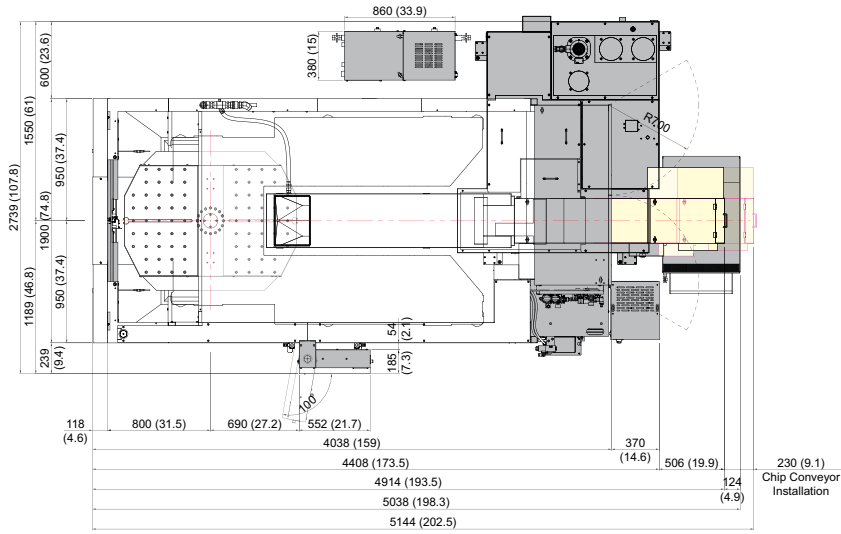

SPECIFICATIONS

External Dimensions

unit : mm(in)

KV60D (Rear Chip Conveyor : Standard)

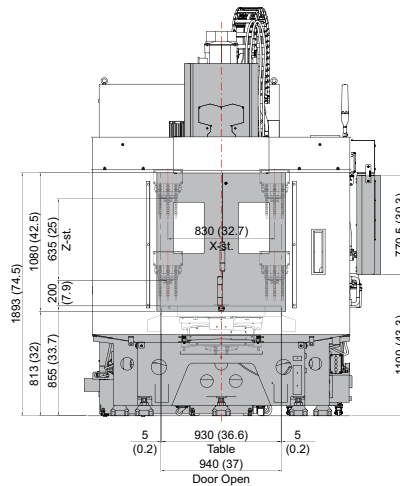
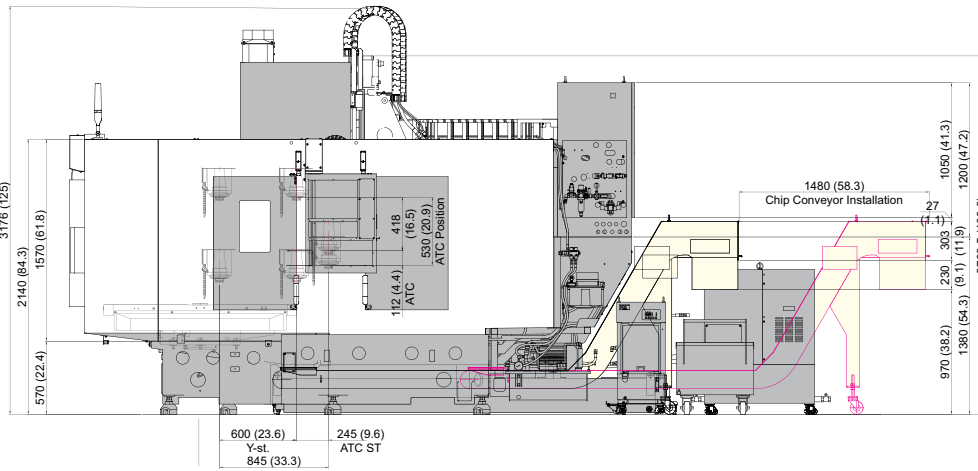
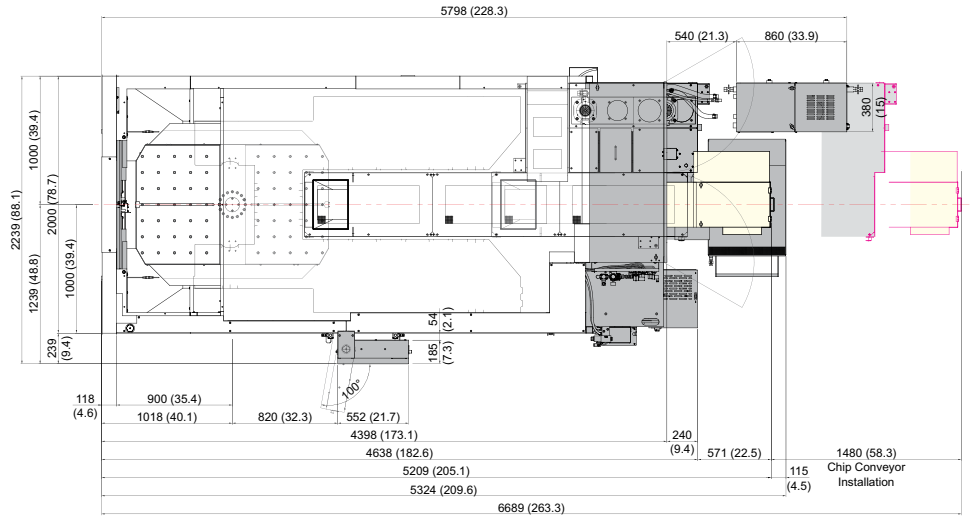

SPECIFICATIONS

Table Dimensions

unit : mm(in)

KV43D

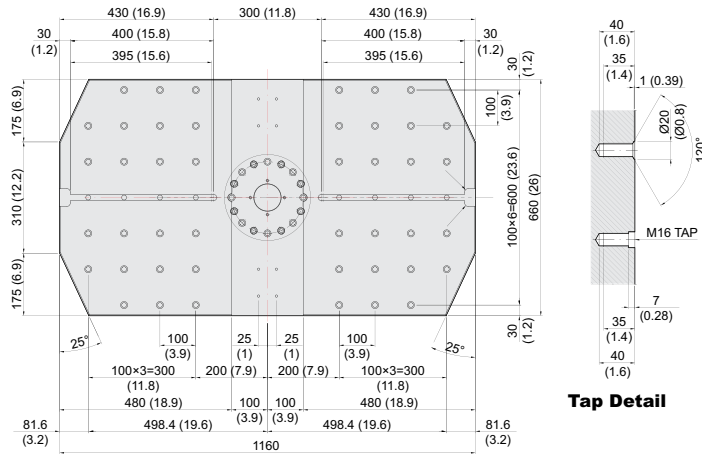

KV52D

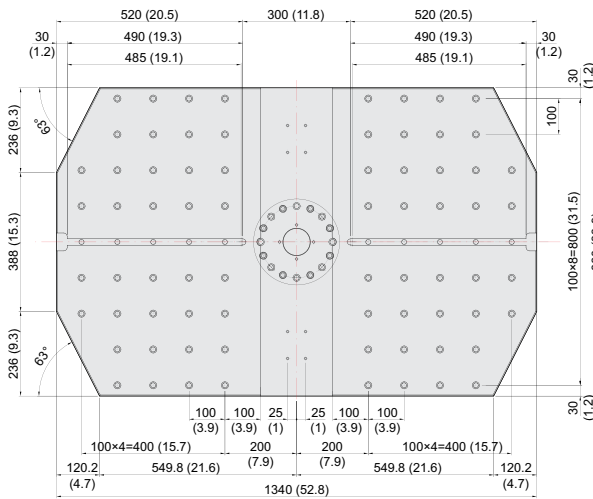

KV60D

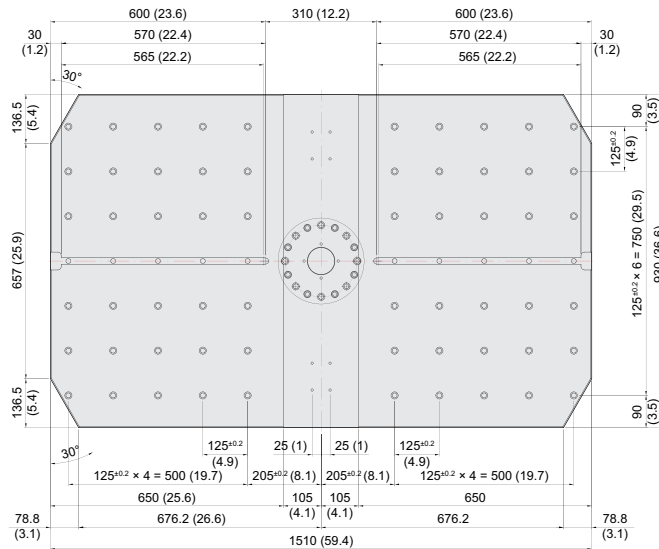

SPECIFICATIONS

Tool Dimensions

unit : mm

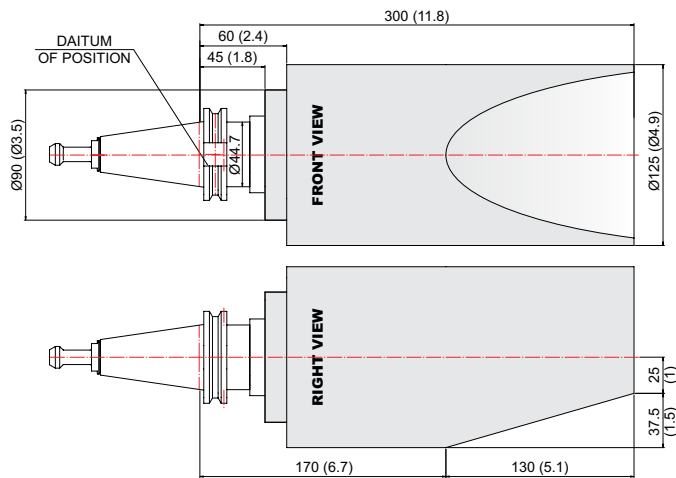
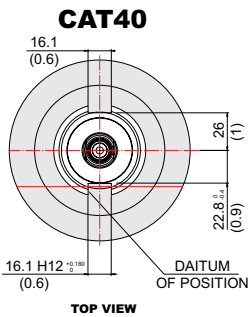
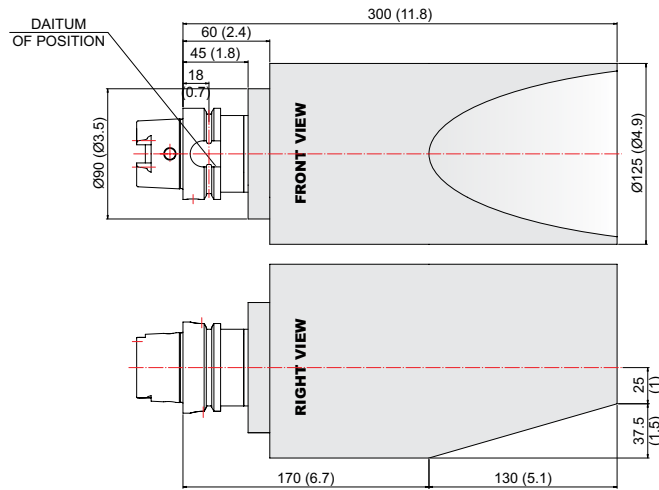
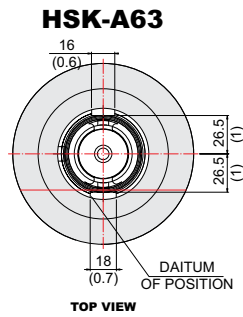
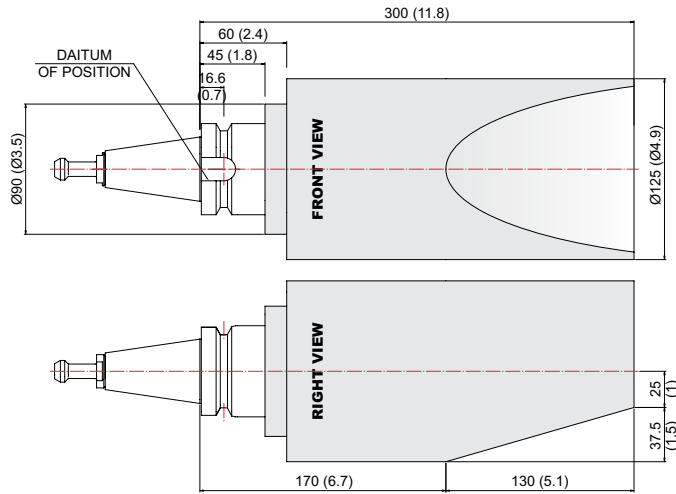
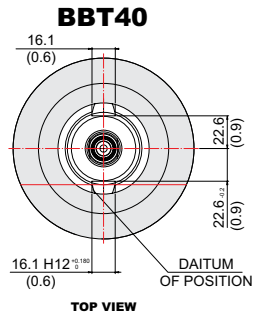

* Please note that the tool length varies depending on the tool diameter.

SPECIFICATIONS

Tool Shank

unit : mm(in)

BT40/BBT40, BIG PLUS

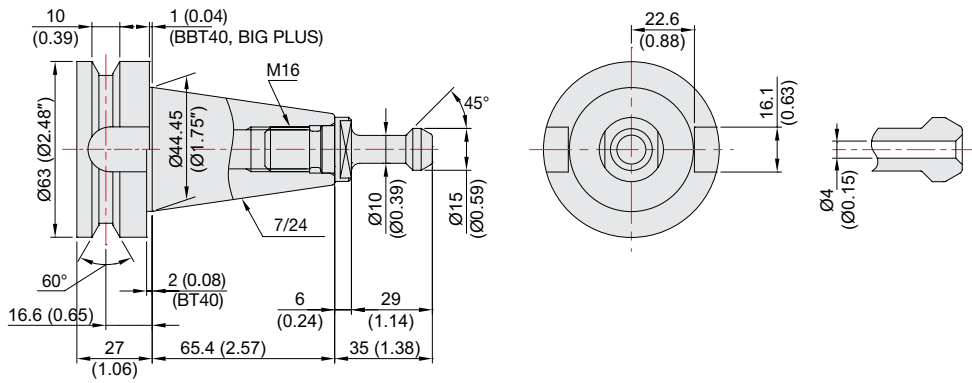

HSK A-63

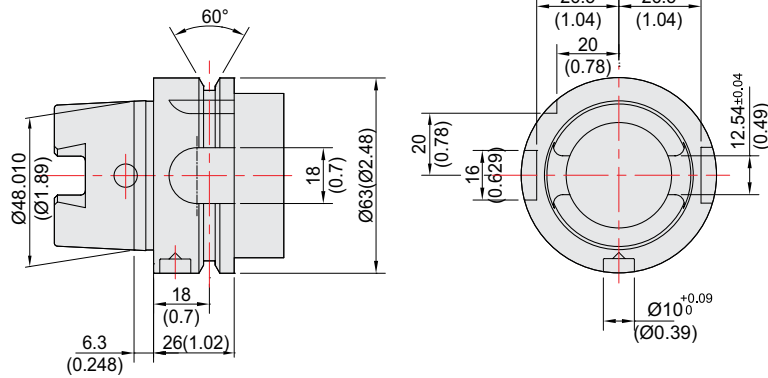

CAT40/BCV40

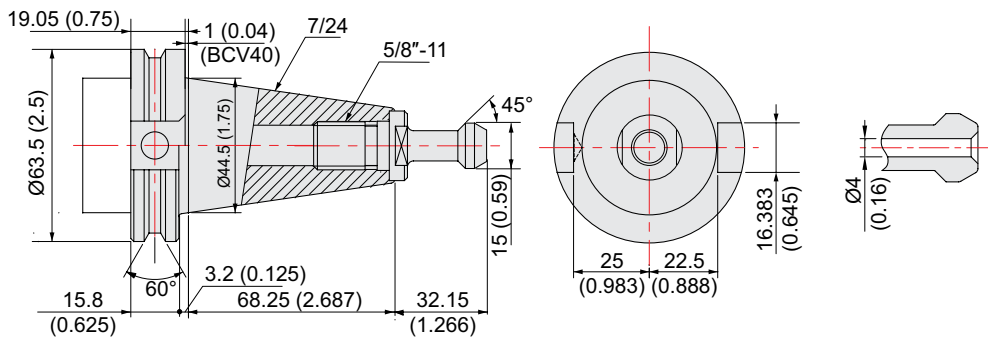

SPECIFICATIONS

Specifications

[] : Option

ITEM		KV43D	KV52D	KV60D
TABLE	Table Size	mm(in) 2-660×480 (26"×18.9")	2-860×570 (33.9"×22.4")	2-950×650 (37.4"×25.6")
	Maximum Load Capacity	kg(lb) 2-300 (661)	2-350 (772)	2-500 (1,102)
	Table Change Time	sec 5	5.5	8.3
	Change Method	-	Rotary Turn	
	Table Driving Method	-	Rotating Cylinder	
FEED	Travel	X/Y/Z mm 560/430/570 (22.1"/20.5"/22.4")	760/520/570 (29.5"/20.5"/22.4")	830/600/635 (32.7"/23.6"/25")
	Rapid Traverse Rate	X/Y/Z m/min(ipm) 42/42/42 (1,654/1,654/1,654)		
	Slide Type	-	Roller Guide	
ATC	Tool Shank	-	BBT40 [HSK-A63]	
	Number of Tools	EA 42 : Pick-up Type	45 : Pick-up Type	
	Max. Tool Dia. (W.T / W.O)	mm(in) Ø80/Ø125 (Ø3.1"/Ø4.9")		
	Max. Tool Length	mm(in) Ø50 : 300 (11.8") / Ø125 : 170 (6.7")		
	Max. Tool Weight	kg(lb) BBT40 : 8 (17.6) [HSK-A63 : 5 (11)]		
	Tool Selection Method	-	Fixed	
	Tool Change Time	C-C sec 4.6	4.7	4.8
TANK CAPACITY	Coolant Tank	ℓ (gal) 415 (109.6)		
	Lubricating Tank	ℓ (gal) 4 (1.1)		
	Air Consumption (0.5MPa)	ℓ/min 470		
POWER SUPPLY	Electric Power Supply	kVA 34		
	Thickness of Power Cable	mm ² Over 35		
	Voltage	V/Hz 220/60 (200/50)		
MACHINE	Floor Space (L×W)	mm(in) 1,796×4,200 (70.7"×165.4")	1,900×4,290 (74.8"×168.9")	2,000×4,398 (78.7"×173.1")
	Height	mm(in) 3,096 (121.9")	3,176 (125")	
	Weight	kg(lb) 7,000 (15,432)	8,400 (18,519)	9,100 (20,062)
NC	Controller	-	FANUC i Series - Smart Plus [FANUC 31i-B Plus]	

Spindle

[] : Option

Speed r/min	Power (Max./Cont.) kW (HP)	Torque (Max./Cont.) N·m (lbf·ft)	Driving Method	Spindle Taper
8,000	18.5/15 (25/20)	118/95.5 (87/70.4)	DIRECT	BBT40 [HSK-A63]
[8,000 : High-torque]	15/11 (20/15)	286/143 (210.9/105.5)		
[12,000]	18.5/11 (25/15)	118/52.5 (87/38.7)		
[15,000]	18.5/11 (25/15)	118/52.5 (87/38.7)		

CONTROLLER

FANUC i Series – Smart Plus

[] : Option ☆ Needed technical consultation

Controlled axis / Display / Accuracy Compensation	
Control axis	3 axis (X, Y, Z) [4 axis (X, Y, Z, A)] [5 axis (X, Y, Z, A, C)]
Simultaneously controlled axis	3 axis [Max. 4 axis]
Least setting Unit	X, Y, Z axis : 0.001 mm (0.0001 inch) B axis : 1 deg [0.001] deg
Least input increment	X, Y, Z axis : 0.001 mm (0.0001 inch) B axis : 1 deg [0.001] deg
Inch / Metric conversion	
High response vector control	
Interlock	All axis / Each axis
Machine lock	All axis
Backlash compensation	± 0 ~ 9999 pulses (Rapid traverse / Cutting feed)
Position switch	
LCD / MDI	15 inch LCD unit (with Touch Panel)
Feedback	Absolute motor feedback
Stored stroke check 1	Over travel
Stored stroke check 2, 3	
Stored pitch error compensation	
Operation	
Automatic operation (Memory)	
MDI operation	
DNC operation	Needed DNC software / CF card
Program restart	
Wrong operation prevention	
Program check function	Dry run, Program check, Z axis Machine lock Stored limit check before move
Single block	
Search function	Program Number / Sequence Number
Handle interruption	
Interpolation functions	
Nano interpolation	
Positioning	G00
Linear interpolation	G01
Circular interpolation	G02, G03
Exact stop mode	Single : G09, Continuous : G61
Dwell	G04, 0 ~ 9999.9999 sec
Skip	G31
Reference position return	1st reference, G28 / 2nd reference, G30 Ref. position check, G27
Single direction positioning	G60
Thread synchronous cutting	G33
Helical interpolation	Circular + Linear 2 axis (Max.)
Feed function / Acc. & Dec. control	
Manual feed	Rapid traverse Jog : 0~2,000mm/min (79 ipm) Manual handle : x1, x10, x100 pulses Reference position return
Cutting Feed command	Direct input F code
Feedrate override	0 ~ 200% (10% Unit)
Rapid traverse override	1%, 25%, 50%, 100%
Override cancel	
Feed per minute	G94
Feed per revolution	G95
Cylindrical interpolation	G07.1
Inverse time feed	G93
Look-ahead block	200 blocks (AI APC)
Program input	
Tape Code	EIA / ISO
Optional block skip	9 ea
Absolute / Incremental program	G90 / G91
Program stop / end	M00, M01 / M02, M30
Maximum command unit	± 999,999,999 mm (± 99,999,9999 inch)
Plane selection	X-Y, G17 / Z-X, G18 / Y-Z, G19
Workpiece coordinate system	G52, G53, 48 pairs (G54.1 P1 ~ 48)
Manual absolute	Fixed ON
Programmable data input	G10
Sub program call	10 folds nested
Custom macro	#100 ~ #199, #500 ~ #999
Programmable mirror image	G51.1, G50.1
G code preventing buffering	G4.1
Optional chamfering corner R	

Program input	
Polar coordinate command	G15, G16
Canned cycle	G73, G74, G76, G80 ~ G89
Scaling	G50, G51
Coordinate system rotation	G68, G69
Conversational Program	Smart Guide-i
Auxiliary function / Spindle speed function	
Level-up M Code	Multi / Bypass M code
Spindle speed function	S & 5 digit , Binary output
Spindle override	0% ~ 150% (10% Unit)
Spindle orientation	M19
Retraction for rigid tapping	
FSSB high speed rigid tapping	
Tool function / Tool compensation	
Tool function	Max. T8 digit
Tool life management	
Tool offset pairs	400 pairs
Tool nose / radius compensation	G40, G41, G42
Tool length offset	G43, G44, G49
Tool offset memory C	Tool geometry and wear (Cutter and tool length)
Tool length measurement	Z axis Input C
Editing function	
Part program storage size	5,120m (2MB)
No. of registerable programs	1,000 ea
Program protect	
Background editing	
Extended part program editing	Copy, move and change of NC program
Memory card program edit	
Data input / output & Interface	
I/O interface	CF card, USB memory Embedded Ethernet interface
Screen hard copy	
External message	
External key input	
External workpiece number search	
Automatic data backup	
Setting, display and diagnosis	
Self-diagnosis function	
History display & Operation	Alarm & Operator message & Operation
Run hour / Parts count display	
Maintenance information	
Actual cutting feedrate display	
Display of spindle speed / T code	
Graphic display	
Operating monitor screen	Spindle / Servo load etc.
Power consumption monitoring	Spindle & Servo
Spindle / Servo setting screen	
Multi language display	Support 24 languages
Display language switching	Selection of 5 optional Languages
LCD Screen Saver	Screen saver
Option	
Fast ethernet	Needed option board
Data server	Needed option board
Protection of data at 8 levels	
Additional Axis	
Manual handle feed	2/3 units #100 ~ #199, #500 ~ #999, #98000 ~ #98499
Add. Workpiece	Max. 300 pairs (G54.1 P1 ~ P300)
AICC II	400 blocks ☆

Figures in inch are converted from metric values.

The FANUC controller specifications are subject to change based on the policy of company CNC supplying.

CONTROLLER

FANUC 31i-B Plus

[]: Option ☆ Needed technical consultation

Controlled axis / Display / Accuracy Compensation	
Control axis	3 axis (X, Y, Z) [4 axis (X, Y, Z, A)]
Simultaneously controlled axis	3 axis [Max. 4 axis]
Least setting Unit	X, Y, Z axis : 0.001 mm (0.0001 inch) B axis : 1 deg [0.001] deg
Least input increment	X, Y, Z axis : 0.001 mm (0.0001 inch) B axis : 1 deg [0.001] deg
Inch / Metric conversion	G20 / G21
High response vector control	
Interlock	All axis / Each axis
Machine lock	All axis
Backlash compensation	± 0 ~ 9999 pulses (Rapid traverse / Cutting feed)
Position switch	
LCD / MDI	15" color LCD with Touch screen
Feedback	Absolute motor feedback
Stored stroke check 1	Over travel
Stored stroke check 2, 3	
Pitch error compensation	
Operation	
Automatic operation (Memory)	
MDI operation	
DNC operation	Needed DNC software / CF card
Program restart	
Wrong operation prevention	
Program check function	Dry run, Program check Z axis Machine lock, Stroke check before move
Single block	
Search function	Program Number / Sequence Number
Retraction for rigid tapping	
Manual guide i	Smart Guide i
Interpolation functions	
Nano interpolation	
Positioning	G00
Linear interpolation	G01
Cylindrical interpolation	G02, G03
Exact stop mode	Single : G09, Continuous : G61
One-way positioning	G60
Inverse-time feed	G93
Dwell	G04, 0 ~ 9999.9999 sec
Skip	G31
Reference position return	1st reference : G28 2, 3, 4 reference : G30 P2, P3, P4 Ref. position check : Z7
Thread synchronous cutting	G33
Helical interpolation	Circular + Linear interpolation 2 axis (max.)
Feed function / Acc. & Dec. control	
Manual feed	Rapid traverse Jog : 0~5,000mm/min (197 ipm) Manual handle : x1, x10, x100 pulses Reference position return
Cutting Feed command	Direct input F code
Feedrate override	0 ~ 200% (10% Unit)
Rapid traverse override	F0% (F1%), F25%, F50%, F100%
Override cancel	
Feed per minute	G94
Feed per revolution	G95
Look-ahead block	1,000 Block
Program input	
Tape Code	EIA / ISO
Optional block skip	9 ea
Absolute / Incremental program	G90 / G91
Program stop / end	M00, M01 / M02, M30
Maximum command unit	± 999,999.999 mm (± 99,999.9999 inch)
Plane selection	X-Y : G17 / Z-X : G18 / Y-Z : G19
Workpiece coordinate system	G52, G53, 48 pairs (G54.1 P1 ~ P48)
Manual absolute	Fixed ON
Programmable data input	G10
Sub program call	10 folds nested
Custom macro	#100~#199, #500~#599, #98000~#98499
Programmable mirror image	G51.1, G50.1

Controlled axis / Display / Accuracy Compensation	
Polar coordinate command	G15, G16
Do not look ahead function	G4.1
Including Chamfering / Corner R	
Canned cycle	G73, G74, G76, G80 ~ G89
Coordinate rotation	G68, G69
Scaling	G50, G51
Auxiliary function / Spindle speed function	
Auxiliary function	M 4 digit
Level-up M Code	Multi / By-Pass
Spindle speed command	S 5 digit , Binary output
Spindle override	50% ~ 120% (10% Unit)
Spindle orientation	M19
FSSB high speed rigid tapping	
Tool function / Tool compensation	
Tool function	Max. T 8 digit
Tool life management	256 pairs ☆
Tool offset pairs	400 pairs
Tool nose radius compensation	G40, G41, G42
Tool nose length compensation	G43, G44, G49
Tool offset memory C	Tool length, diameter, abrasion(length, diameter)
Tool length measurement	Z axis Input C
Editing function	
Part program storage size	10240m (4MB)
No. of registerable programs	1,000 ea
Program protect	
Background editing	
Extended part program editing	
Memory card program edit	Copy, move and change of file program
Protection of data at 8 levels	
Data input / output & Interface	
I/O interface	Memory card, USB memory interface Embedded Ethernet interface
Screen hard copy	
External message	
External key input	
External workpiece number search	
Automatic data backup	
Setting, display and diagnosis	
Self-diagnosis function	
History display	Alarm & Operator message & Operation
Run hour / Parts count display	
Maintenance information	
Actual cutting feedrate display	
Display of spindle speed / T code	
Graphic display	
Operating monitor screen	
Power consumption monitoring	Spindle & Servo
Multi language display	Support 25 languages
Display language switching	Selection of 5 optional Languages
LCD Screen Saver	Screen saver
Macro Excutor	Custom software 8MB (WIA Screen)☆
Processing select	Speed/ridigity setting
Option	
Fast ethernet	Needed option board
Data server	Needed option board (1GB, 2G, 4GB)
Sub Spindle control	☆
Polar coordinate interpolation	G12.1, G13.1
Cylindrical interpolation	G07.1
Manual handle feed	2/3 units
Tool management function	
Tool offset number	Max. 2,000 pair
Program storage capacity	~ 8 MByte
Program registration number	Max. 4,000 ea
Additional work coordinate	300 pair (G54.1 P1 ~ P300)

Figures in inch are converted from metric values.

The FANUC controller specifications are subject to change based on the policy of company CNC supplying.