

2200TTSYY

TCM22TTSY | TCM22TTSYC

SG WIA CNC Multi Axis Turning Center

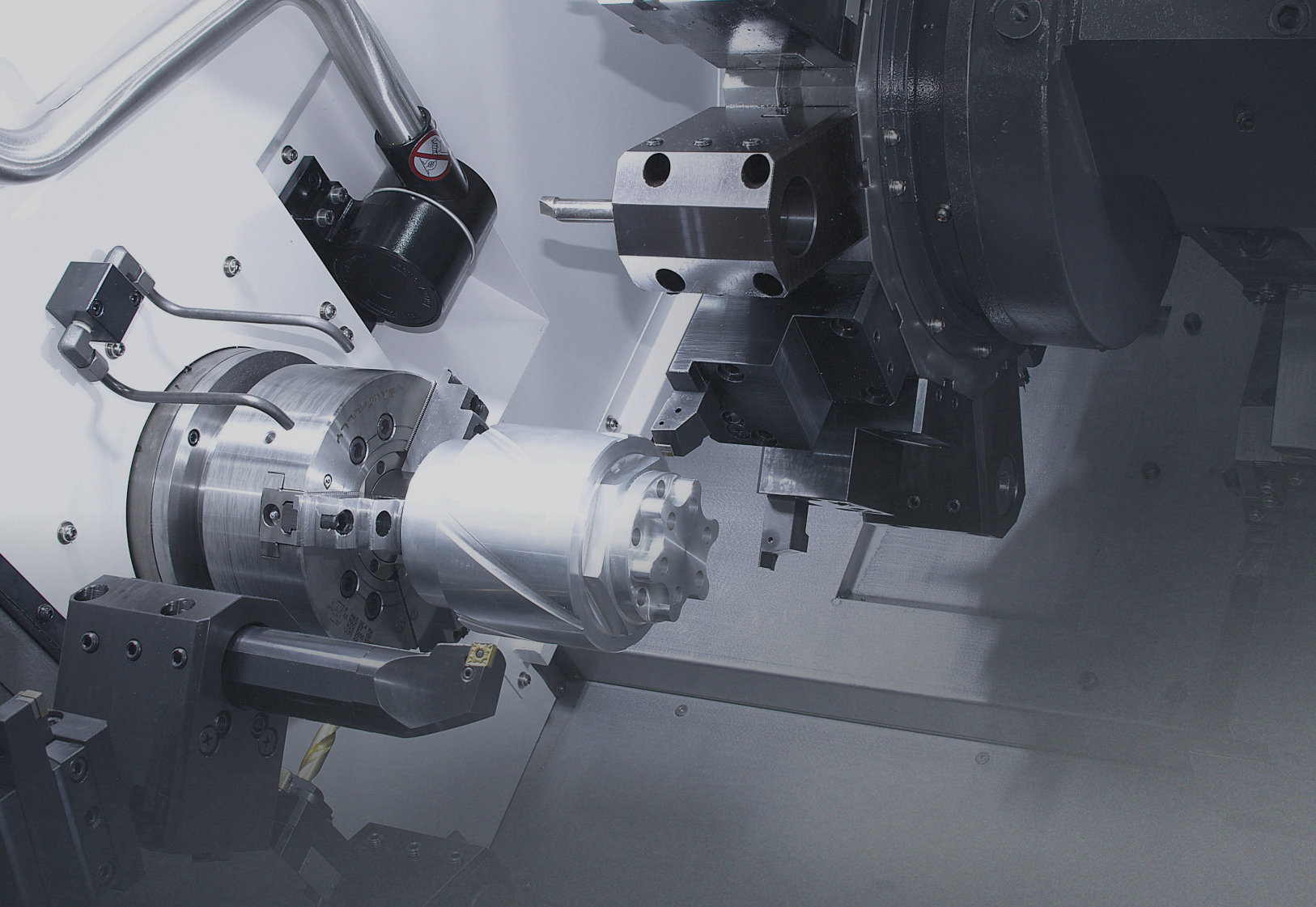

Technical Leader

The CNC Turning Center TCM22TTSYY/C, designed by SG WIA with years of expertise and the latest technology, is designed to maximize productivity by utilizing twin spindles and twin turrets.

		TCM22TTSYY	TCM22TTSYYC
Max. Turning Dia.	mm(in)	Upper : Ø230 (Ø9.1") / Lower : Ø230 (Ø9.1")	
Max. Turning Length	mm(in)	230 (9.1") <1st, 2nd Sp. Separate Workpiece Chucking>	
Chuck Size	inch	1st : 8" 2nd : 8"	1st : 10" 2nd : 8"
Bar Capacity	mm(in)	1st : Ø65 (Ø2.6") 2nd : Ø65 (Ø2.6")	1st : Ø81 (Ø3.2") 2nd : Ø65 (Ø2.6")
Spindle Speed	r/min	4,500	3,500
Sp. Power (Max./Cont.)	kW(HP)	18.5/15 (25/20)	18.5/15 (25/20)
No. of Tools	EA	2×12 [2×24] (BMT55)	
Travel	mm(in)	X1/Y1/Z1/X2/Y2/Z2/ZB : 165/100/700/165/100/700/730 (6.5"/3.9"/27.6"/6.5"/3.9"/27.6"/28.7")	
Rapid Traverse Rate	m/min	X1/Y1/Z1/X2/Y2/Z2/ZB : 20/10/36/20/10/36/36	

[] : Option

- Complex machining ability enhanced through upper/lower twin turret & twin Y-axis structure
- Front & rear surface machining with twin spindle
- Hybrid travel structure with box guide & roller LM guide combination
- Diverse work piece size coverage with 8" & 10" spindle configuration
- High performance latest FANUC control applied



01 BASIC STRUCTURE

Twin Spindle and Turret for High Productivity – Multitasking CNC Turning Center

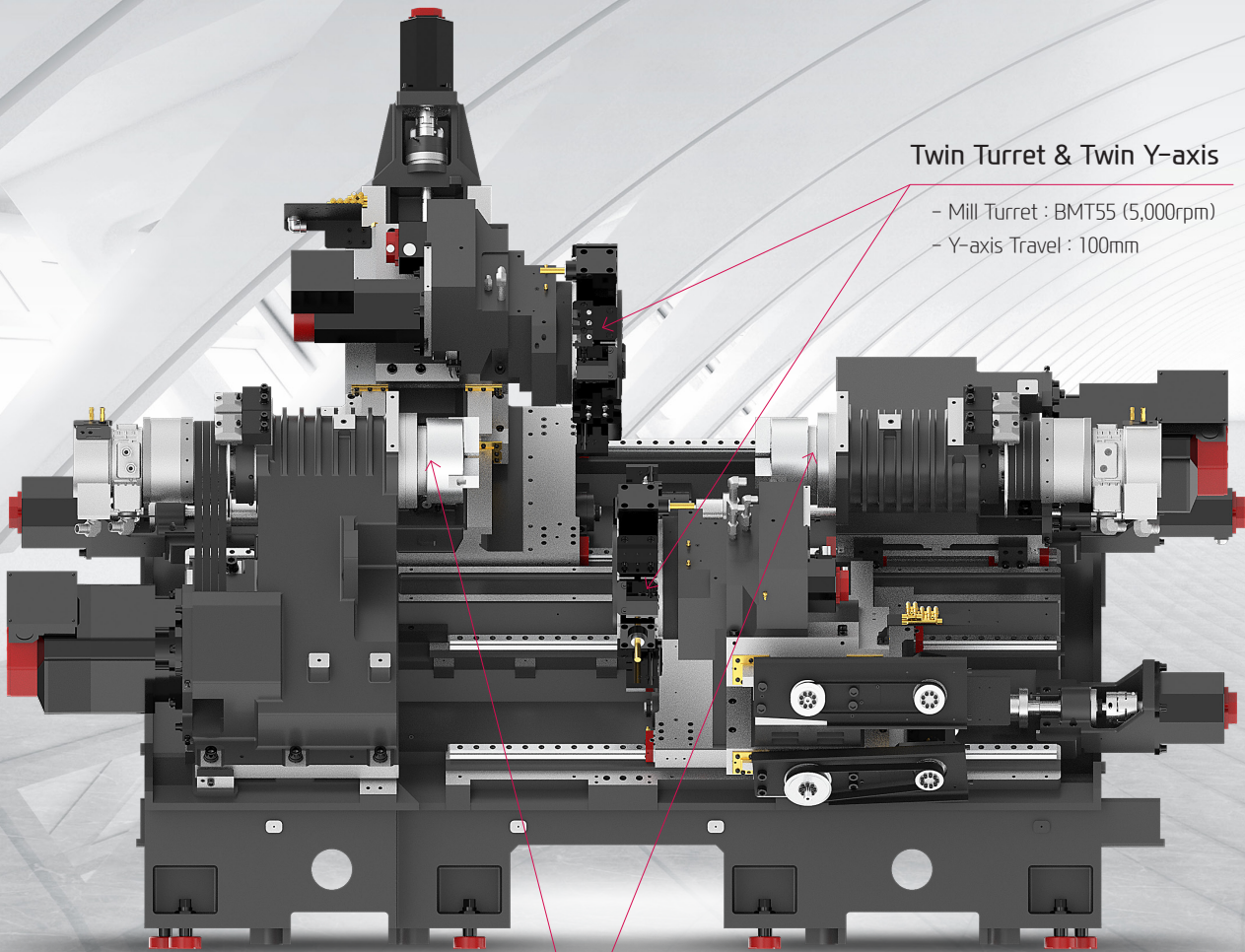

Twin Turret & Twin Y-axis

- Mill Turret : BMT55 (5,000rpm)
- Y-axis Travel : 100mm

Twin Spindle

- TCM22TTSYY - 8" : 4,500 [5,000] rpm
- TCM22TTSYYC - 10" : 3,500 [3,500] rpm
- C-Axis Control : 0.001°

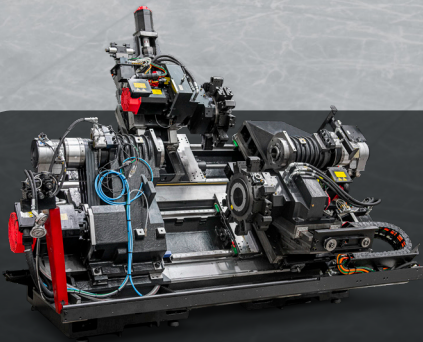

High Precision, High Rigidity Bed Structure

The TCM22TTSYY features a one-piece 45° slant bed design based on FEM analysis to provide improvement in vibration absorption and thermal displacement. This unique design ensures stable and precise processing.

REDUCTION OF NON-CUTTING TIME BY FAST RAPID SPEED

GUIDEWAY

Hybrid Slideway

Each axis on the TCM22TTSYY is designed with slideways that optimize the characteristics of the axis. For the X/Y-axis, box guideways are used to endure heavy load.

For the Z-axis, roller type LM guideways are used to optimize feed capability.

Ball Screw

In order to eliminate thermal growth and increase accuracy, all axis are driven by high precision double anchored ballscrews.

Box Guide

Roller LM Guide

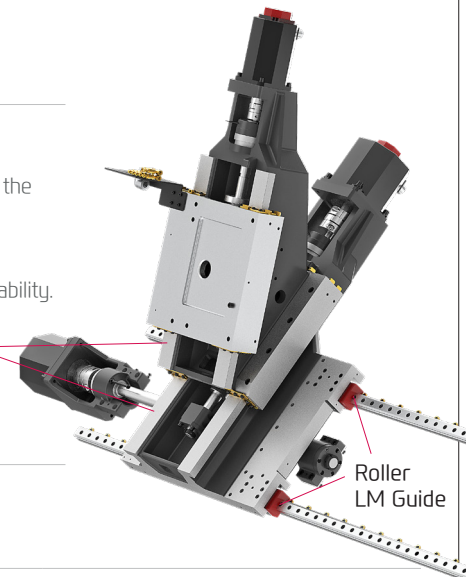

Rapid Traverse Rate (X1/Y1/Z1/X2/Y2/Z2/ZB)

20/10/36/20/10/36/36 m/min (787/394/1,417/787/394/1,417/1,417 ipm)

Travel (X1/Y1/Z1/X2/Y2/Z2/ZB)

165/100{±50}/700/165/100{±50}/700/730 mm

(6.5"/3.9"{±2"}/27.6"/6.5"/3.9"{±2"}/27.6"/28.7")

Advantages of X/Y-axis Box Guide Application

- X-axis face cutting feed increase & enhanced surface finishing

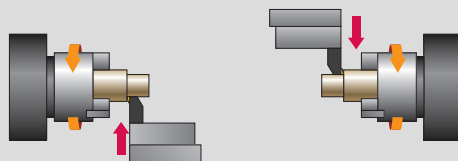

- X/Y-axis milling cutting feed increase & enhanced milling surface finishing

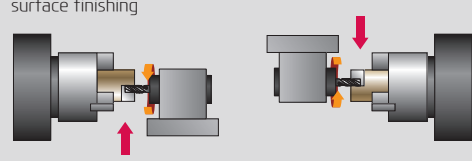

- X/Y-axis face milling cutting feed increase & enhanced milling surface finishing

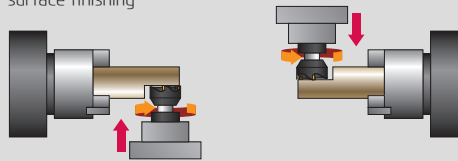

- X/Y-axis drilling & tapping ability enhanced

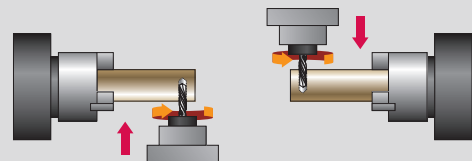

MACHINING PROCESS WITH ONLY ONE INITIAL SETTING

Y-AXIS

Wedge Type Y-Axis Structure

The TCM22TTSYY is designed with a wedge type Y-axis that is transferred by the simultaneous operation of the Ys-axis and the X-axis. In addition, excellent rigidity makes it possible to perform superb quality during heavy-duty cutting.

- Y1/Y2-axis Rapid Traverse Rate : 10 m/min (394 ipm)
- Y1/Y2-axis Travel : 100 (±50) mm (3.9" {±2"})

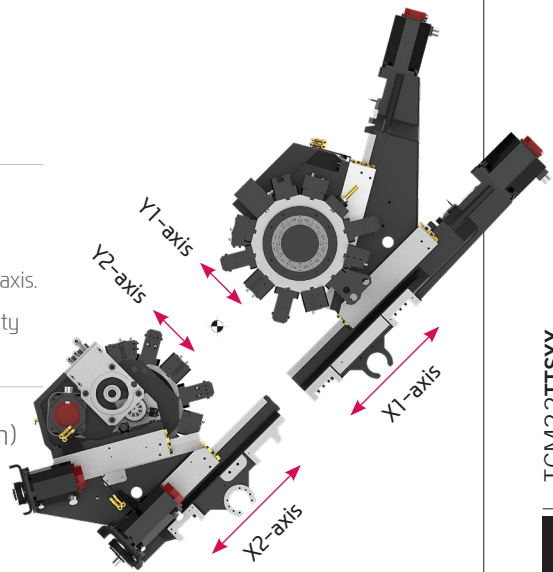

UPPER/LOWER TWIN Y-AXIS STRUCTURE

Compared to previous upper Y-axis only multi tasking machine, TCM22TTSYY is equipped with lower Y-axis which enhances Y-axis complex machining abilities.

Advantages of Lower Y-axis Application

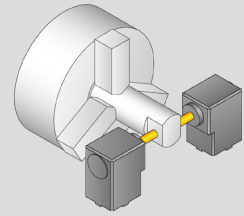
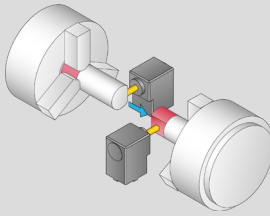
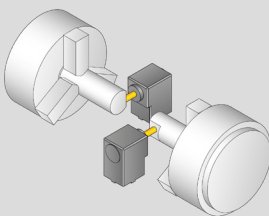
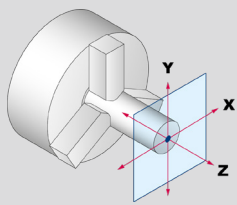
<ul style="list-style-type: none"> Upper/lower Y-axis turret usage → Cycle time decrease  <p>Vibration decrease through simultaneous machining</p>	<ul style="list-style-type: none"> Work piece rear side Y-axis machining possible  <p>Complex work piece machining</p>
<ul style="list-style-type: none"> Two units of Y-axis work piece machining simultaneously  <p>Productivity doubled</p>	<ul style="list-style-type: none"> Lower turret zero point setting  <p>Convenience enhanced</p>

TCM22TTSYY

03 HIGH PRECISION SPINDLE

High-performance Spindle for Powerful Cutting and Precision

Spindle Specifications

[] : Option

Model	Spindle Speed	Motor (Max./Cont.)	Torque (Max.)	Chuck Size
TCM22TTSYY (1st/2nd Spindle)	4,500 rpm	18.5/15 kW (25/20 HP)	206 N·m (151.9 lbft·ft)	8"
	[5,000 rpm]	[25/15 kW (33.5/20 HP)]	[223 N·m (164.5 lbft·ft)]	
TCM22TTSYYC (1st Spindle)	3,500 rpm	18.5/15 kW (25/20 HP)	286 N·m (210.9 lbft·ft)	10"
	[3,500 rpm]	[22/18.5 kW (29.5/25 HP)]	[244 N·m (180 lbft·ft)]	
TCM22TTSYYC (2nd Spindle)	4,500 rpm	18.5/15 kW (25/20 HP)	206 N·m (151.9 lbft·ft)	8"
	[5,000 rpm]	[25/15 kW (33.5/20 HP)]	[223 N·m (164.5 lbft·ft)]	

HIGH CUTTING PERFORMANCE & ACCURACY

SPINDLE

High Performance Twin Spindle

TCM22TTSYY spindle adopts the same bearing structure as large turning centers, combination of double cylindrical roller bearing & angular contact bearing, which provides heavy duty high performance.

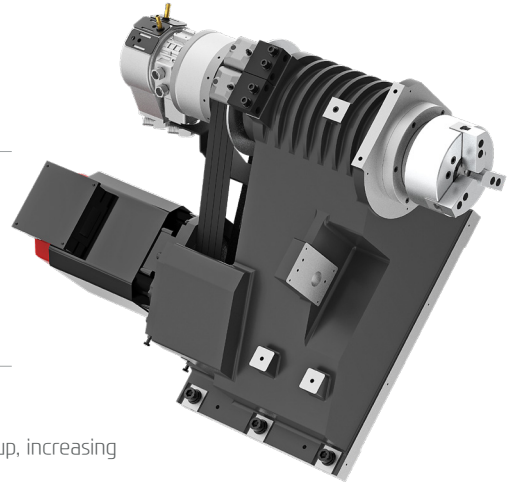

2nd Spindle

2nd spindle can perform secondary operations with a single setup, increasing flexibility and productivity.

C-Axis Control

C-axis of TCM22TTSYY can be controlled to 0.001° which makes it possible to process various shapes.

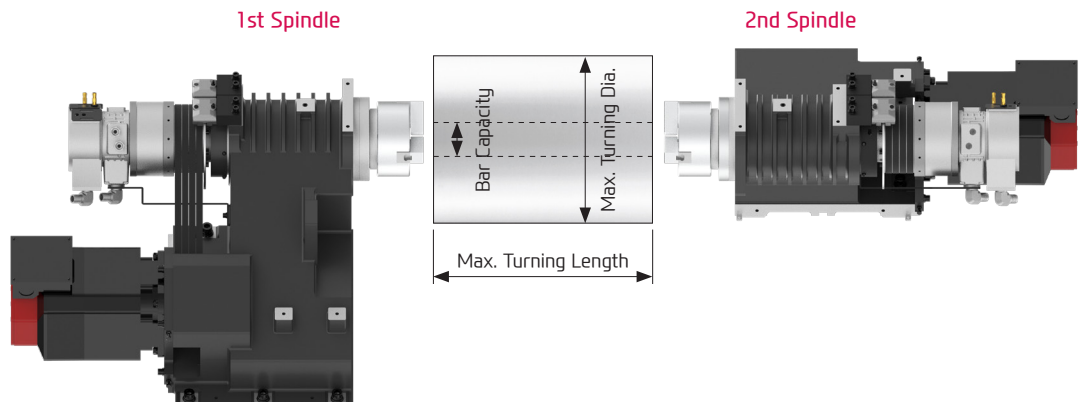

Item	TCM22TTSYY		TCM22TTSYYC	
	1st Spindle	2nd Spindle	1st Spindle	2nd Spindle
Spindle Type	-			
Max. Turning Dia.	mm(in) $\varnothing 230$ ($\varnothing 9.1$ ")			
Max. Turning Length	mm(in) 230 (9.1") <1st, 2nd Sp. Separate Workpiece Chucking>			
	673 (26.5") <1st, 2nd Sp. Synchronized>		660 (26") <1st, 2nd Sp. Synchronized>	
Chuck Size	inch 8"		10"	8"
Bar Capacity	mm(in) $\varnothing 65$ ($\varnothing 2.6$ ")		$\varnothing 81$ ($\varnothing 3.2$ ")	$\varnothing 65$ ($\varnothing 2.6$ ")

TCM22TTSYY

04 BMT TURRET

High speed, High Accuracy, Highly Reliable Servo Type Turret

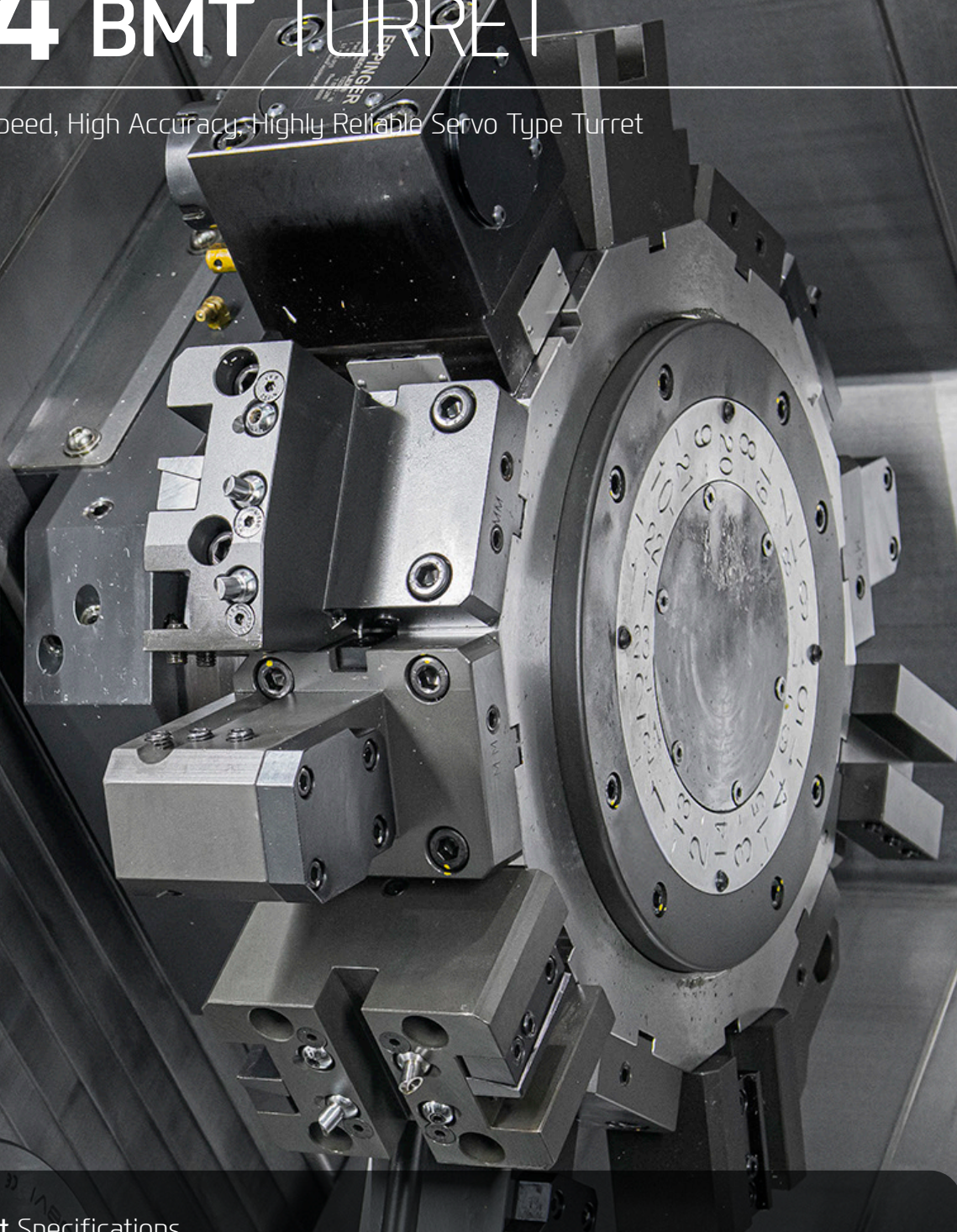

Mill Turret Specifications

[] : Option

Type	Speed	Motor (Max./Cont)	Torque (Max./Cont)	Collet Size
BMT55 (12 [24] Position)	5,000 rpm	5.5/3.7 kW (7.5/5 HP)	52.5/26.5 N·m (38.7/19.5 lbft-ft)	Ø16 (Ø5/8")
	[5,000 rpm]	[7.5/1.5 kW (10/2 HP)]	[47.7/16.9 N·m (35.2/12.5 lbft-ft)]	<ER25>

BMT TURRET WITH POWERFUL CUTTING

TURRET

Mill Turret

The upper and the lower turrets are equipped with powerful servo motors, which guarantee high productivity and precision.

In particular, a total of 24 (Option 48) tools can be installed on both turrets, and high speed precision machining of complex products is possible with a single setup.

- ⦿ Speed (rpm) : 5,000 r/min
- ⦿ Collet size : $\varnothing 16$ ($\varnothing 5/8''$) {ER25}
- ⦿ Indexing Time : 0.15 sec

STRAIGHT MILLING HEAD



ANGULAR MILLING HEAD

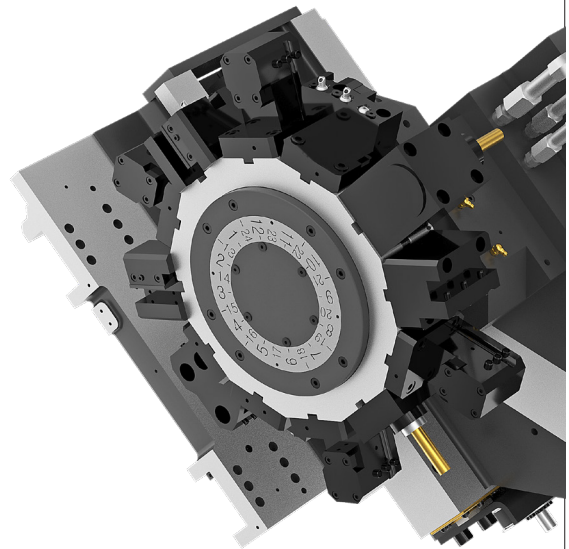

Mill Tool Holder

Machining capability has increased with the addition of straight milling head tool holder, which can machine workpieces from the side, and angular milling head tool holder, which can perform I.D. operations.

SPECIAL TOOL

OPTION

With the Y-axis, the TCM22TTSYY can process high value-added products using a variety of rotating tools. In particular, there is a multi-holder for attaching a variety of tools to one holder, and an eccentric rotary tool for handling eccentric parts without additional axis travel, which can realize integration of process with one machine.

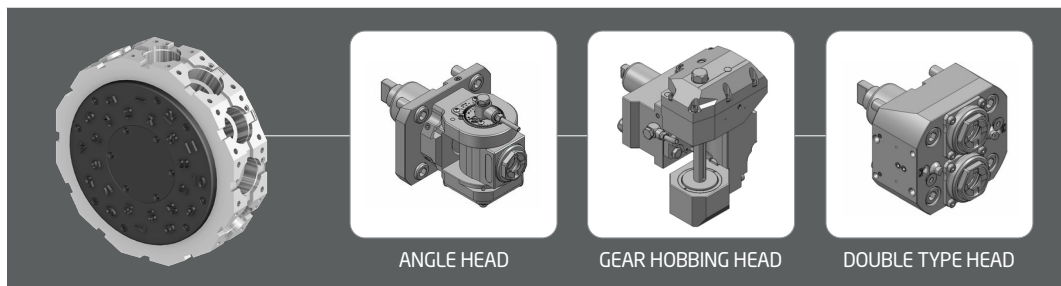

ANGLE HEAD

GEAR HOBGING HEAD

DOUBLE TYPE HEAD

❖ Consultation needed when ordering these options.

05 FANUC – Smart Plus

The Compatible All-round Control



15" Touch-type Monitor as a standard



Fast Cycle Time Technology	Smart Machine Control	Fine Surface Technology
Smart Servo Control Technology	Conversational Program	SmartGuide-i
Machining-aid Function	i-HMI	5120M (2MB)
No. of Registerable Programs 1000 EA	Part Program Storage	

Servo Learning Oscillation Function for Chip Breaking **OPTION**

- Machining Method : he tool cuts the workpiece moving in a zigzag pattern. (Oscillating) → Air cut section occurs → Long chips break
- Advantage : Increase tool life, Enhance surface finishing, Improve chip disposal
- Machine : All turning centers with FANUC controller (Option)

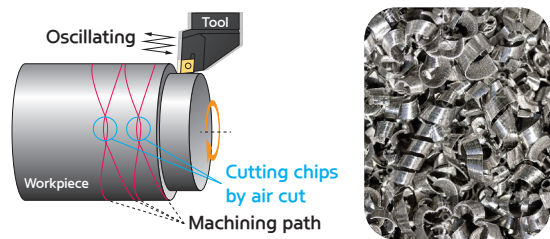

CHIP BREAKING		TOOL PATH CHECK	
SPINDLE SPEED S (min/rev)	1000	Z	
FEED F (mm/rev)	0.300	C	
FREQUENCY 1 (Hz)	0.500	0°	
AMPLITUDE K (mm)	1.200	360°	
CHIP LENGTH (mm)	100		
FREQUENCY (Hz)	0.3		
AMPLITUDE (mm)	0.600		

MAXIMUM CHIP LENGTH	
MAX. ϕ (mm)	200.000
MINIMUM CHIP LENGTH (mm)	100.000

THE POSITION SURFACE BOXES	
TOOL NOSE RADIUS (mm)	3.000
PRD. Rpt. μ m	41.000

(Developed special screen page for servo learning oscillation function / Even when this function is applied, the cycle time remains same.)

MMS (Machine Monitoring System)

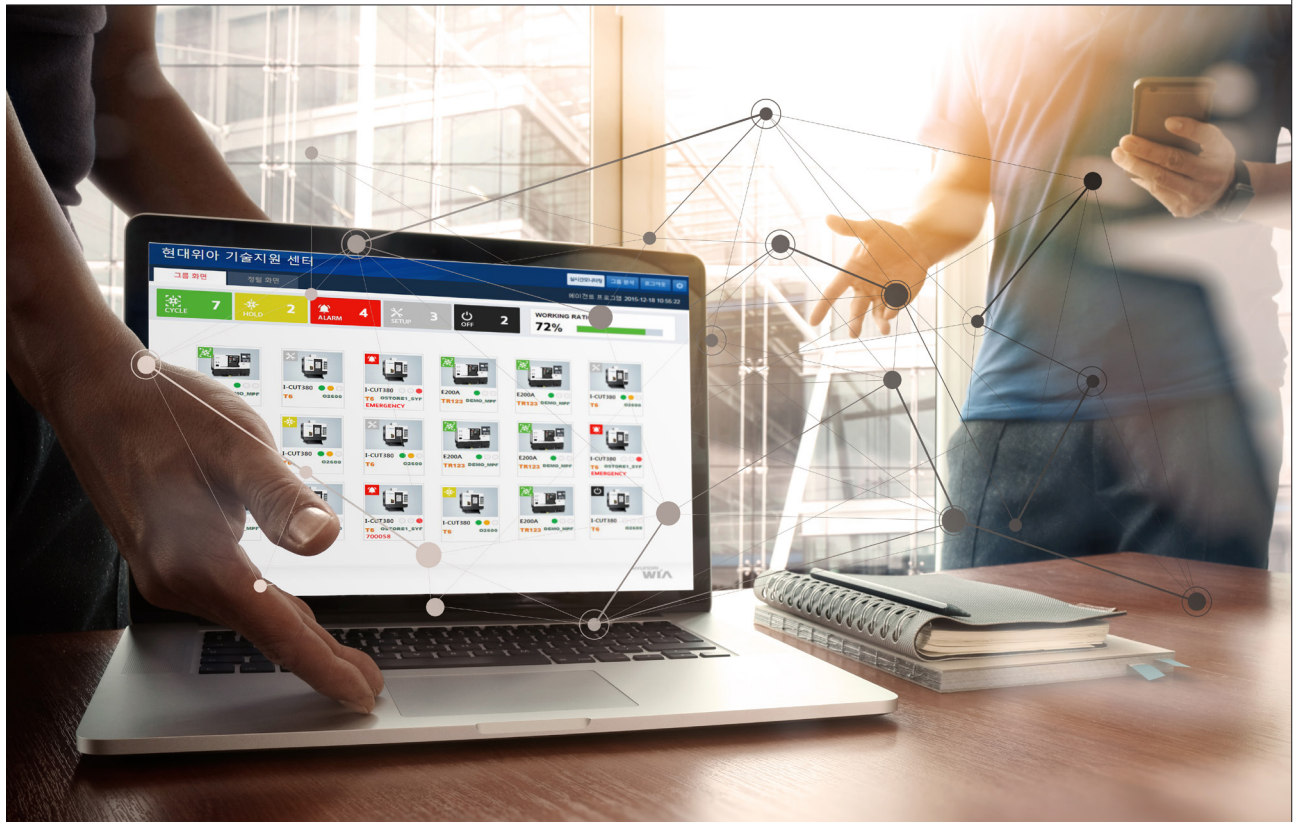

MMS Cloud

A cloud server-based equipment monitoring system for collecting and analyzing facility operation data.

Manufacturing big data solution with design, manufacturing, and intelligence technology of SG-WIA
(Big data collection/Analysis/Visualization)

SMART CNC (FANUC Smart Plus)

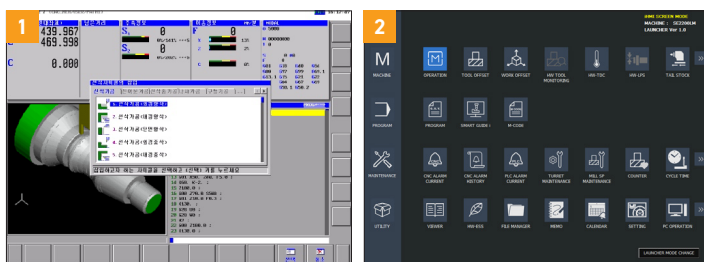

1. Dialogue Program (Smart Guide-i)

This software offers the maximum user convenience through dialogue manipulation from setup to processing. This includes writing processing programs and simulation checks.

2. LAUNCHER

This software offers shortcuts for quick access to specialized features and frequently used features.

06 USER CONVENIENCE

Various Devices for User Friendly

HIGH PRECISION SYSTEM

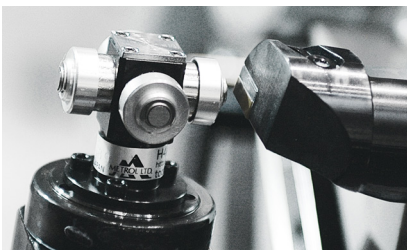

Automatic Q-Setter **OPTION**

Cutting tools are calibrated quickly and accurately with the addition of a q-setter. Each tool tip is touched off manually using a sensor that inputs the position automatically.



Linear Scale **OPTION**

Linear scales increase positioning accuracy and reduce distortion caused by thermal growth, thus ensuring a more accurate finished part. (TCM16/18 Series)



Work Probe **OPTION**

Workpiece coordinate values can be set automatically using the optional spindle probe.

CHIP DISPOSAL SOLUTION

Chip Conveyor

Timely and effective disposal of chips will enhance productivity as well as the working environment.

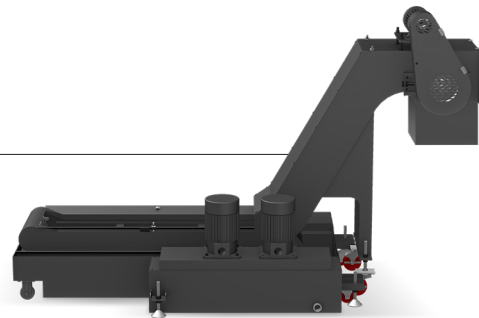

Hinge	Chip Type : Roughing Chip, Long Chip, Chip complex	Material : SS41, 45C, Cast Steel	Front-Right Direction
	Highly efficient when disposing a lot of chips. Capable of handling stringy chips..		
Scraper	Chip Type : Finely broken chip blown out	Material : cast Iron, Nonferrous	
	Convenient for shortly cut chips.		
❖ Drum Filter	Chip Type : Powder, Micro Chip	Material : AL	
	Advantageous in precision, as the chips do not flow in to the coolant nozzle.		

❖ When ordering a drum filter chip conveyor, prior consult with hyudai wia's sales person.

Optional

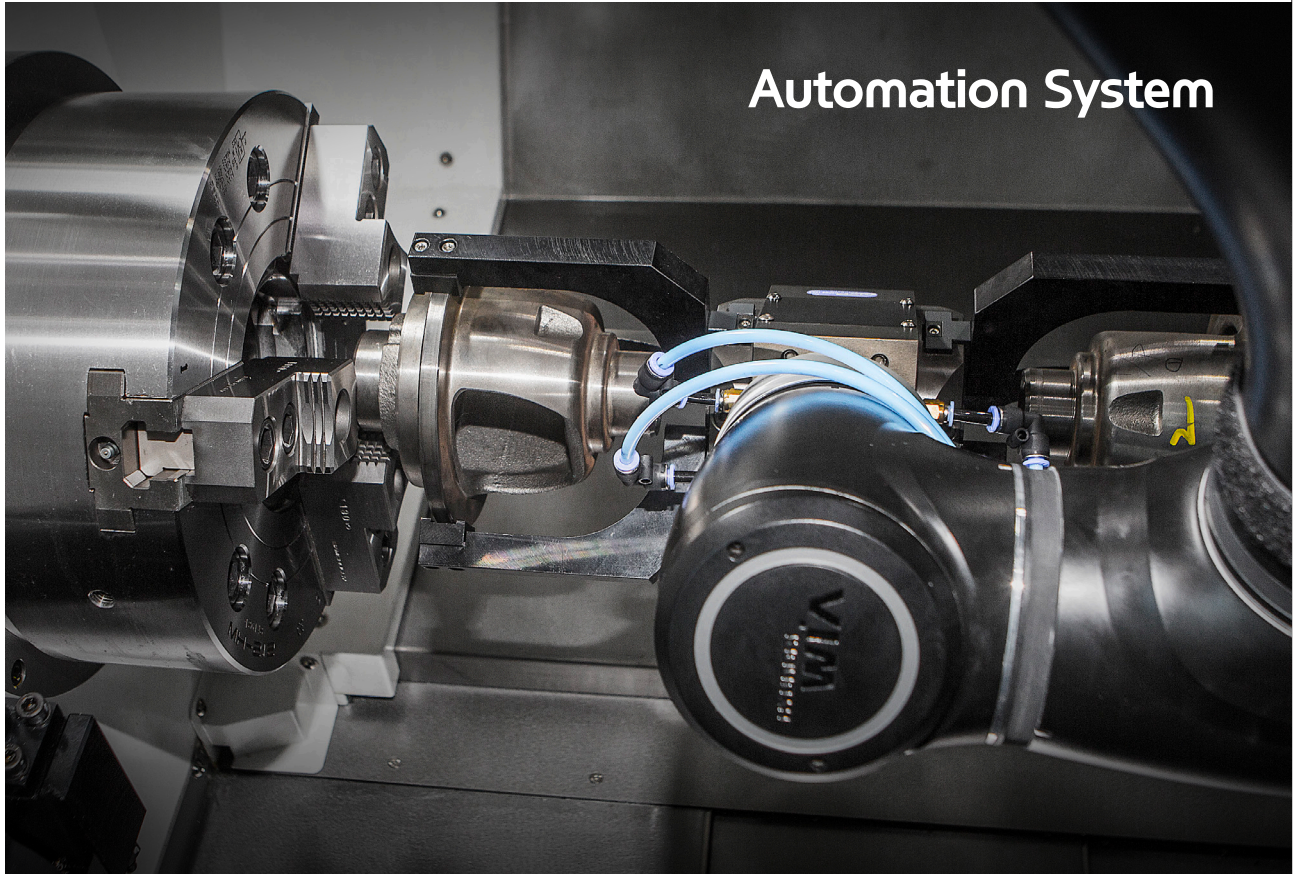

SG WIA
MACHINE TOOL

TCM22TTSY
Multi Axis Turning Center

14
+
15

CREATING VALUE
IN SEAMLESS MOBILITY

Robot System

With its know-how and experience, SG WIA is globally recognized in the field of automation.

Robot automation features flexible responsiveness, convenience and maintenance regardless of type for automation construction.

Bar Feeder System

Bar feeder system enables automation which leads to efficiency improvement.

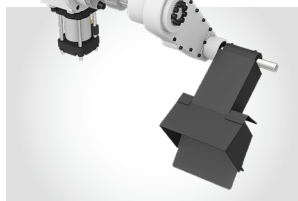

Parts Catcher

An optional parts catcher collects finished parts without the need to open the door, adding productivity, especially when a bar feeder is attached.

SPECIFICATIONS

Standard & Optional

● : Standard ○ : Option ☆ : Prior Consultation - : Non Applicable

Spindle		TCM22TTSYY	TCM22TTSYYC
1st Spindle Hollow Chuck 3 Jaw	8"	●	-
	10"	-	●
	Chuck No	○	○
2nd Spindle Hollow Chuck 3 Jaw	8"	●	●
	No Chuck	○	○
Standard Soft Jaw (1set)		●	●
Chuck Clamp Foot Switch		●	●
2 Steps Hyd. Pressure Device		○	○
Spindle Inside Stopper		○	○
Cs-Axis (0.001")		●	●
Turret			
Tool Holder	2×12EA	●	●
	2×24EA	○	○
Mill Turret	BMT	●	●
Straight Milling Head	Collet Type, 2ea	●	●
Angular Milling Head	Collet Type, 2ea	●	●
Straight Milling Head	Adapter Type	○	○
Angular Milling Head	Adapter Type	○	○
Boring Sleeve		●	●
Drill Socket		●	●
U-Drill Holder		●	●
U-Drill CAP		●	●
Angle Head		☆	☆
Adapter Set		○	○
Tail Stock & Steady Rest			
Built in Programable Tail Stock		-	-
Manual Hyd. Steady Rest		-	-
Coolant & Air Blow			
Standard Coolant (Nozzle)		●	●
Chuck Coolant (Upper Chuck)		○	○
Gun Coolant		○	○
Through Spindle Coolant (Only for Special Chuck)		☆	☆
Thru Coolant for Live Tool		○	○
Chuck Air Blow (Upper Chuck)		●	●
2nd Spindle Air Blow		●	●
Turret Air Blow		☆	☆
Air Gun		○	○
Through Spindle Air Blow (Only for Special Chuck)		☆	☆
High Pressure Coolant	0.5Bar (7.2psi)	●	●
	6Bar (87psi)	○	○
	20Bar (290psi)	○	○
	70Bar (1,015psi)	○	○
Power Coolant System (For Automation)		☆	☆
Coolant Chiller		-	-
Chip Disposal			
Coolant Tank	320ℓ (84.5 gal)-Side	●	●
	320ℓ (84.5 gal)-Rear	○	○
Chip Conveyor (Hinge/Scraper)	Front (Rear)	○	○
	Front (Right)	○	○
Special Chip Conveyor (Drum Filter)		-	-
Chip Wagon	Standard (180ℓ [47.5 gal])	○	○
	Swing (200ℓ [52.8 gal])	○	○
	Large Swing (290ℓ [76.6 gal])	○	○
	Large Size (330ℓ [87.2 gal])	○	○
	Customized	☆	☆
Safety Device			
Back Spin Torque Limiter (BST)		●	●
Total Splash Guard		●	●
Chuck Hydraulic Pressure Maintenance Interlock		☆	☆

Electric Device		TCM22TTSYY	TCM22TTSYYC
Call Light	1Color : ●	○	○
Call Light & Buzzer	3Color : ● ● ● B	●	●
Electric Cabinet Light		○	○
Remote MPG		●	●
Work Counter	Digital	○	○
Total Counter	Digital	○	○
Tool Counter	Digital	○	○
Multi Tool Counter	Digital	○	○
Electric Circuit Breaker		○	○
Transformer	50KVA	○	-
Auto Power Off)		○	○
Measurement			
Q-Setter		-	-
Automatic Q-Setter		○	○
Work Close Confirmation Device (Only for Special Chuck)	TACO	○	○
	SMC	○	○
Work Setter		☆	☆
HWTM (Tool Monitoring System)		○	○
Linear Scale	X Axis	○	○
	Z Axis	○	○
	X&Y Axis	○	○
Coolant Level Sensor(Only for Chip Conveyor)		☆	☆
Environment			
Air Conditioner		○	○
Oil Mist Collector		☆	☆
Oil Skimmer (Only for Chip Conveyor)		○	○
ML (Minimal Quantity Lubrication)		☆	☆
Fixture & Automation			
Auto Door		○	○
Auto Shutter (Only for Automatic System)		○	○
Sub Operation Panel		☆	☆
Bar Feeder Interface		○	○
Bar Feeder		☆	☆
2nd Sp. Work Eject (Pneumatic Type)		○	○
2nd Sp. Work Pusher (Spring Type)		○	○
Extra M-Code 4ea		○	○
Automation Interface		☆	☆
I/O Extension (IN & OUT)	16 Contact	○	○
	32 Contact	○	○
Parts Catcher	1st Sp.	○	○
	2nd Sp.	-	-
Parts Unloader (2nd Sp.) + Parts Conveyor		○	○
Turret Work Pusher (For Automation)		☆	☆
Parts Conveyor		○	○
Hyd. Device			
Standard Hyd. Cylinder	Hollow	●	●
Standard Hyd. Unit	35bar (507.6psi) / 24ℓ (6.3 gal)	●	●
S/W			
Dialogue Program (HW-DPRO) : FANUC		-	-
DNC software (HW-eDNC)		○	○
Machine Monitoring System (HW-MMS Cloud)		☆	☆
Smart Guide-i : FANUC		●	●
Smart S/W		●	●
ETC			
Tool Box		●	●
Customized Color	Need Munsell No.	☆	☆
CAD & CAM		☆	☆

❖ Thermal Displacement Compensation device is recommended, when more than 6 bar of high pressure coolant is applied, for the high quality machining.
Specifications are subject to change without notice for improvement. / Please refer to the S/W catalog (IRIS) for details by S/W product.

SPECIFICATIONS

Spindle Output/Torque Diagram

TCM22TTSYY 4,500rpm (1st, 2nd / C 2nd)

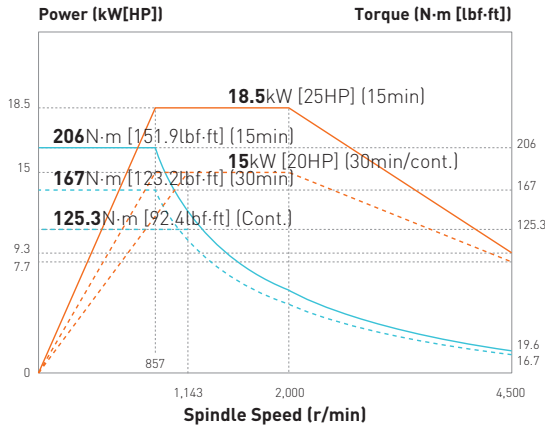

TCM22TTSYY 5,000rpm (1st, 2nd / C 2nd)

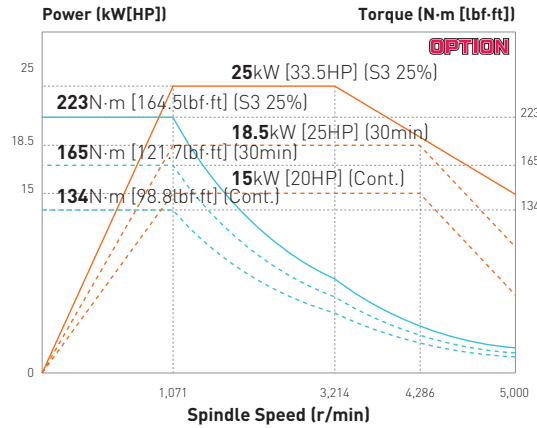

TCM22TTSYYC 3,500rpm (1st)

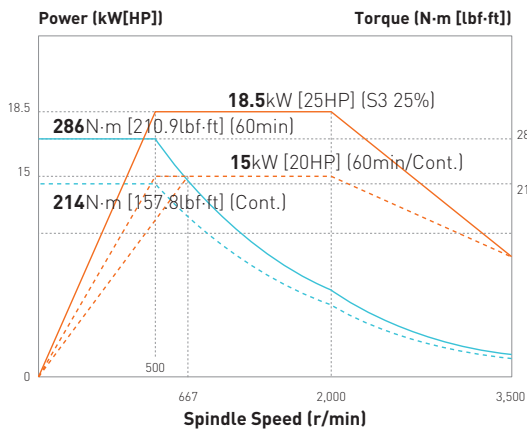

TCM22TTSYYC 3,500rpm (1st)

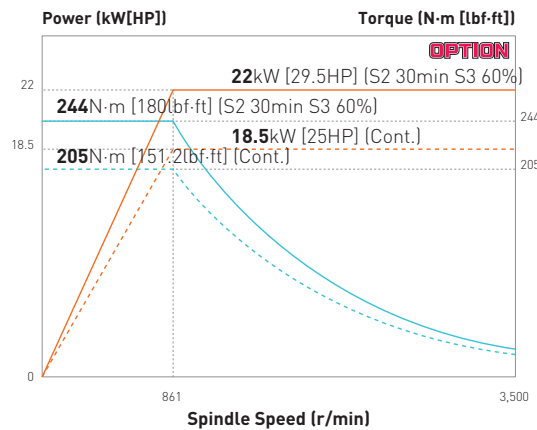

Mill Turret 5,000rpm

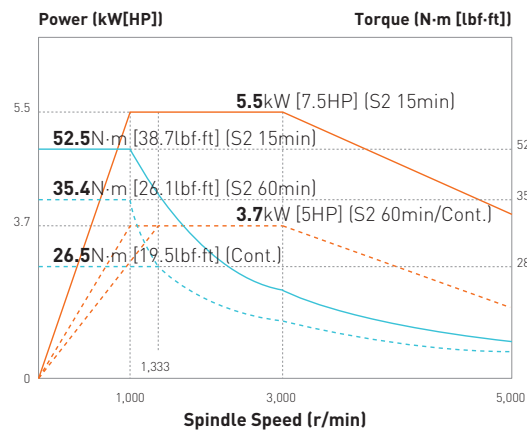

Mill Turret 5,000rpm

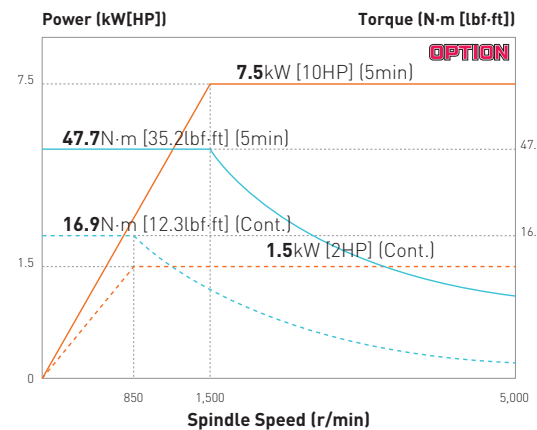

SPECIFICATIONS

External Dimensions

unit : mm(in)

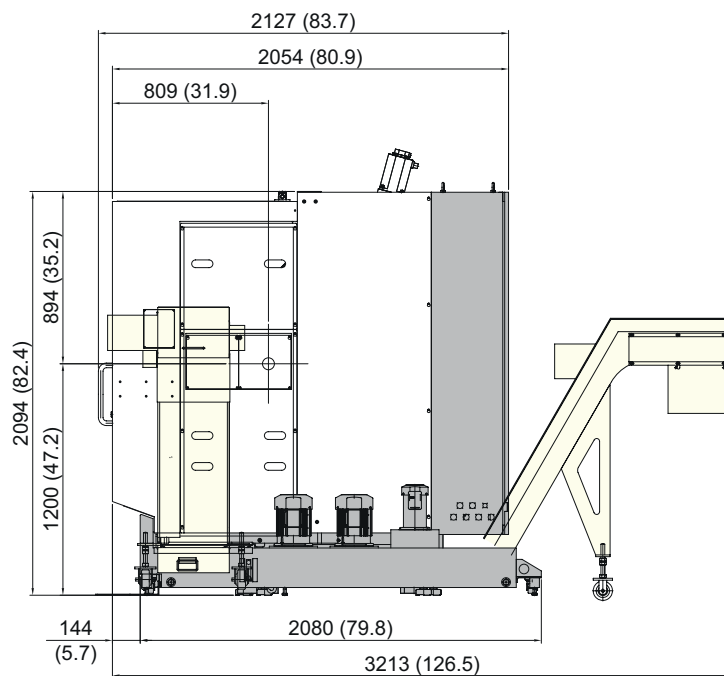
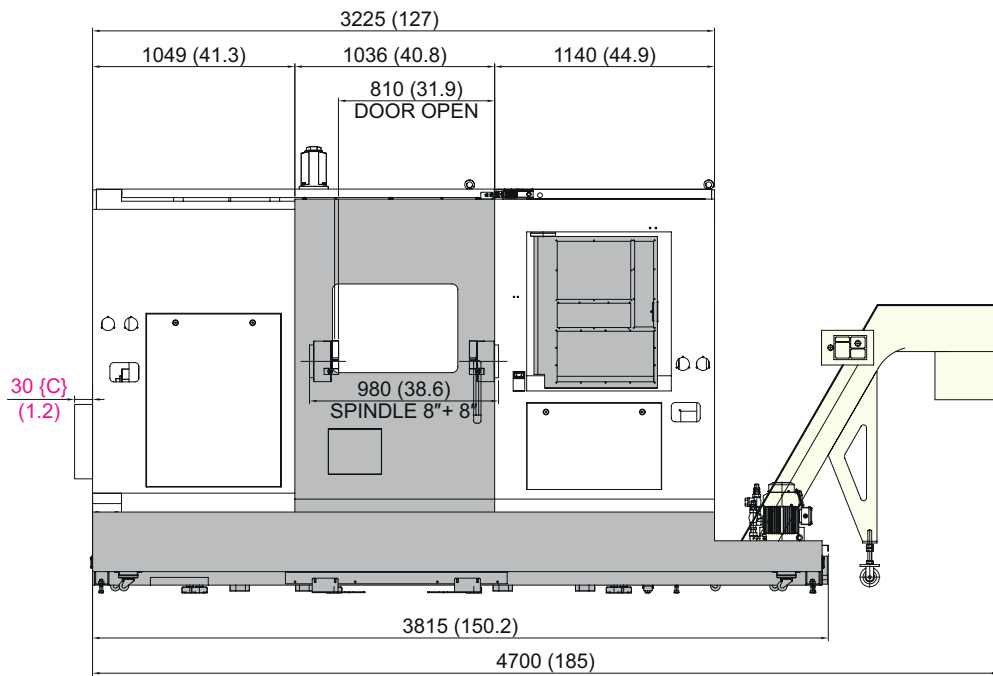

SPECIFICATIONS

Interference

unit : mm(in)

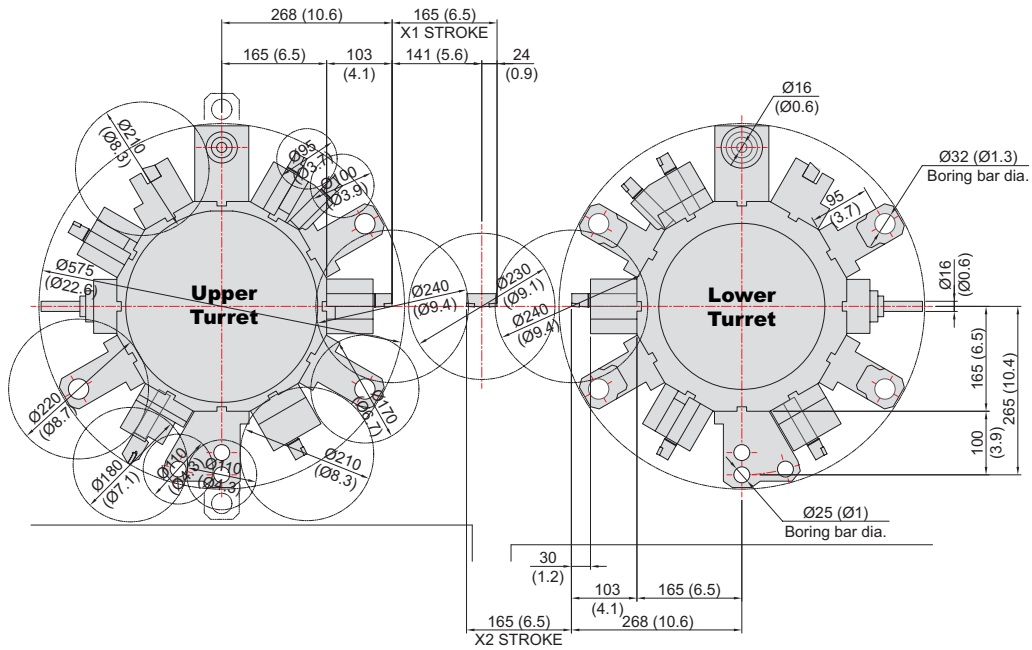

Y-axis Travel Range

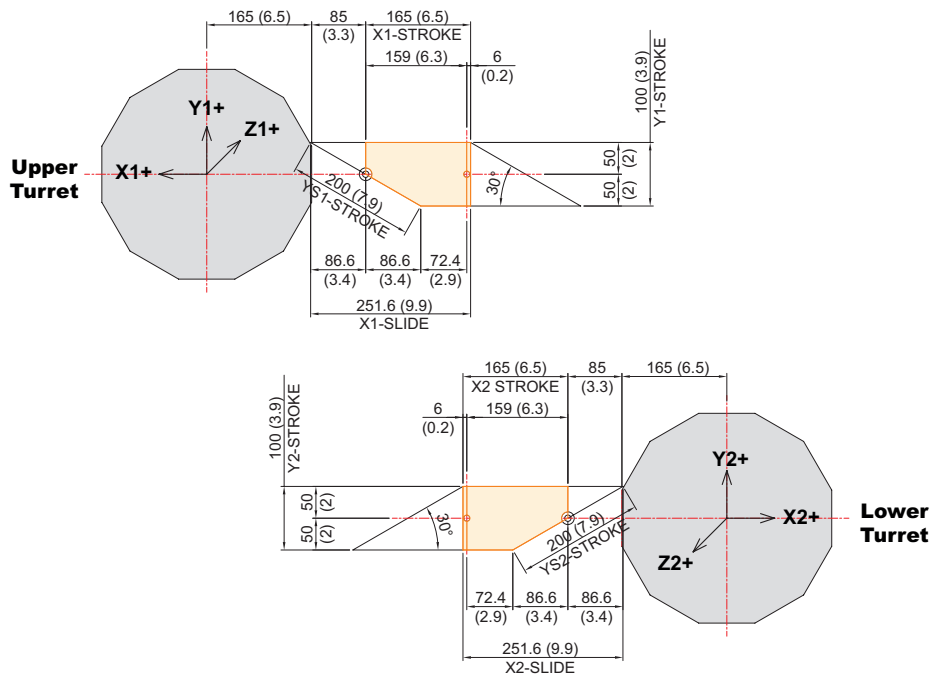

SPECIFICATIONS

Tooling System

unit : mm(in)

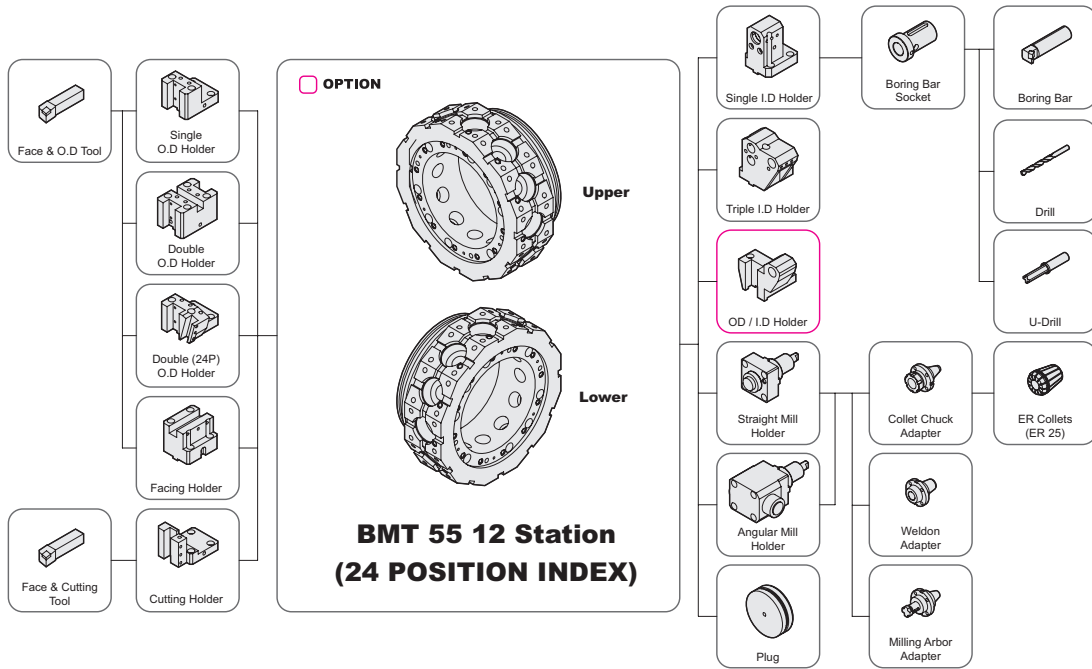

Tooling Parts Detail

ITEM			12 Position		12 Position [Opt. 24P Index Holder]	
			mm Unit	inch Unit	mm Unit	inch Unit
Turning Holder	O.D Holder	Right/Left	4	4	4	4
		Double	2	2	2	2
		Double (24P)	2	2	2	2
	Facing Holder	2	2	2	2	
	O.D & I.D Holder	Opt.	Opt.	Opt.	Opt.	
Cutting Holder	1	1	1	1		
Boring Holder	I.D Holder	Single	7	7	7	7
		Triple	2	2	2	2
	U-Drill Holder	Cap	7	7	7	7
Driven Holder	Straight Mill Holder	Standard	2	2	2	2
		TTC (Tool through Coolant)	Opt.	Opt.	Opt.	Opt.
	Angular Mill Holder	Standard	2	2	2	2
		TTC (Tool through Coolant)	Opt.	Opt.	Opt.	Opt.
Socket	Boring	Ø8 (Ø5/16")	2	2	2	2
		Ø10 (Ø3/8")	2	2	2	2
		Ø12 (Ø1/2")	2	2	2	2
		Ø16 (Ø5/8")	2	2	2	2
		Ø20 (Ø3/4")	2	2	2	2
		Ø25 (Ø1")	2	2	2	2
	Drill	MT 1 × MT 2	2	2	2	2
		MT 2	2	2	2	2
		MT 3	Opt.	Opt.	Opt.	Opt.
	ER Collet	1 Set	1 Set	1 Set	1 Set	
Adapter Set	1 Set	1 Set	1 Set	1 Set		

SPECIFICATIONS

Tooling Travel Range

unit : mm(in)

O.D HOLDER

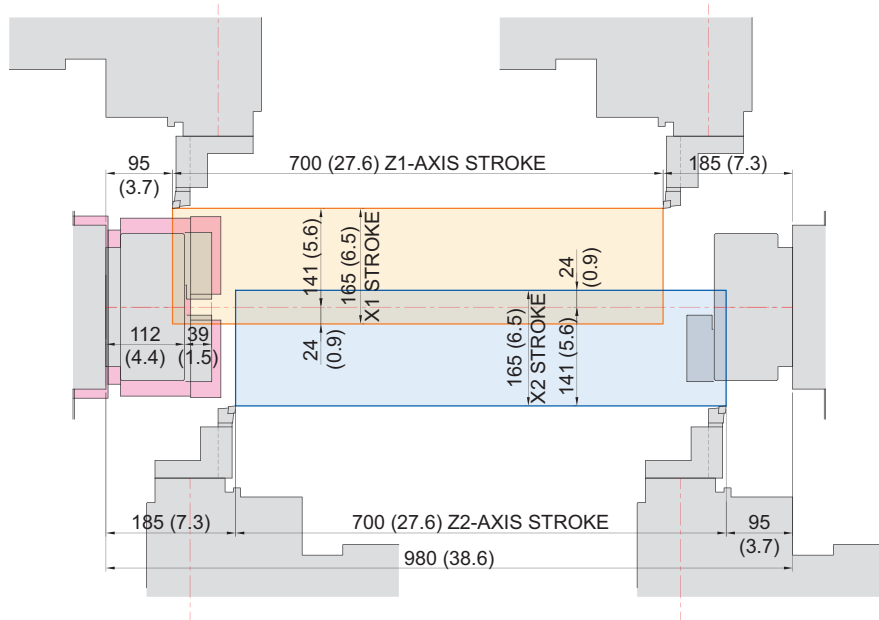

I.D HOLDER

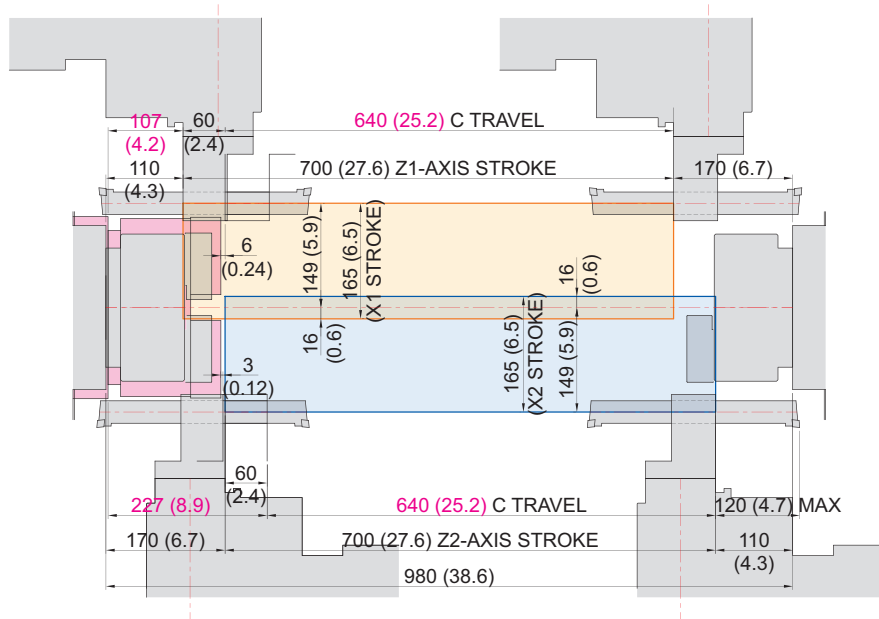

SPECIFICATIONS

Tooling Travel Range

unit : mm(in)

ANGULAR MILL

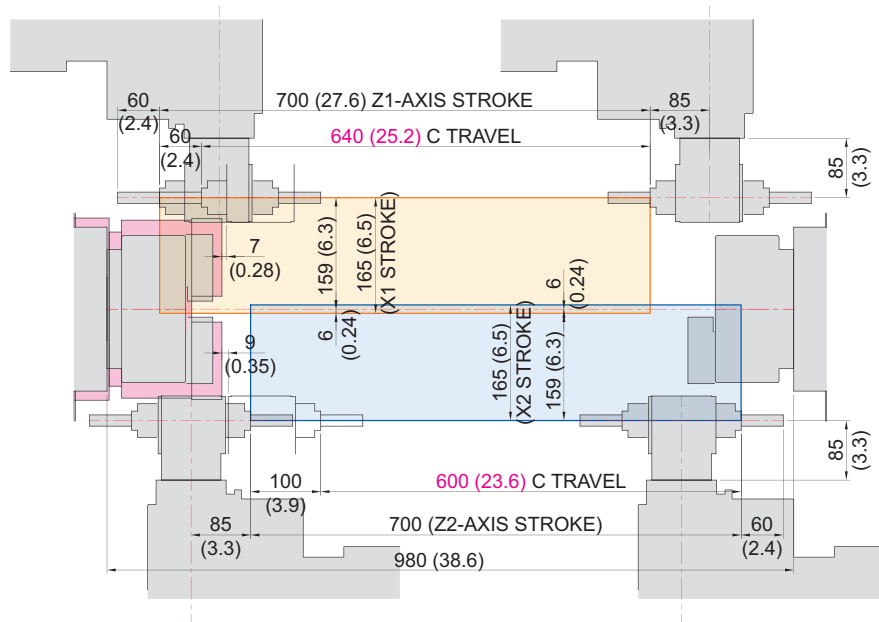

STRAIGHT MILL

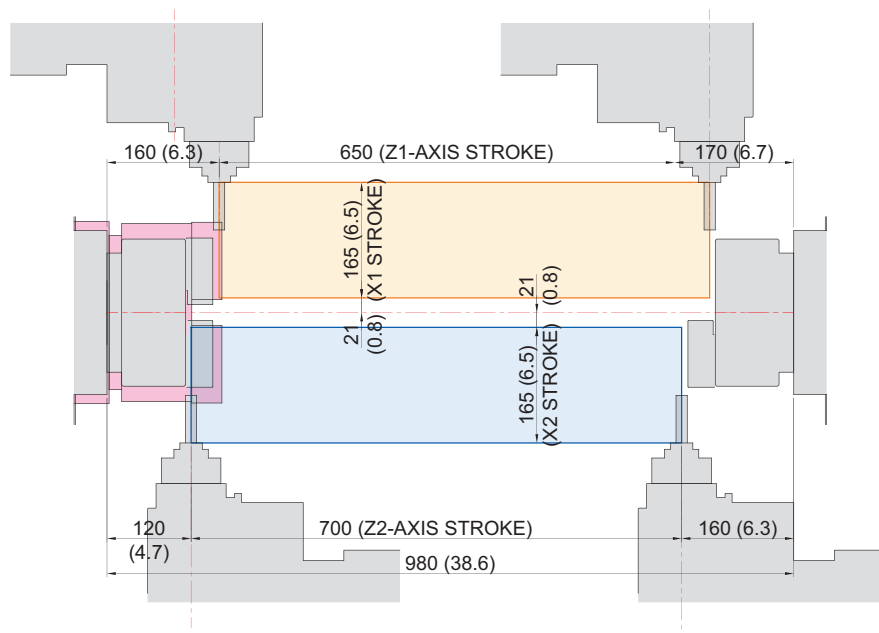

SPECIFICATIONS

Specifications

[] : 선택사양

ITEM			TCM22TTSYY	TCM22TTSYYC	
CAPACITY	Max. Turning Dia.	mm(in)	Ø230 (Ø9.1")		
	Max. Turning Length	mm(in)	230 (9.1") <1st, 2nd Sp. Separate Workpiece Chucking>		
			673 (26.5") <1st, 2nd Sp. Synchronized>	660 (26") <1st, 2nd Sp. Synchronized>	
Bar Capacity	1st	mm(in)	Ø65 (Ø2.6")	Ø81 (Ø3.2")	
	2nd	mm(in)	Ø65 (Ø2.6")		
SPINDLE	Chuck Size	1st	mm(in)	8"	
		2nd	mm(in)	10"	
	Spindle Bore	1st	mm(in)	Ø76 (Ø3")	Ø91 (Ø3.6")
		2nd	mm(in)	Ø76 (Ø3")	
	Spindle Speed (rpm)	1st	r/min	4,500 [5,000]	3,500 [3,500]
		2nd	r/min	4,500 [5,000]	
	Motor (Max/Cont.)	1st	kW(HP)	18.5/15 (25/20) [25/15 (33.5/20)]	18.5/15 (25/20) [22/18.5 (29.5/25)]
		2nd	kW(HP)	18.5/15 (25/20) [25/15 (33.5/20)]	
	Torque (Max/Cont.)	1st	N-m(lbf-ft)	206/125.3 (151.9/62.4) [223/136 (164.5/100.3)]	286/214 (210.9/157.8) [244/205 (180/151.2)]
		2nd	N-m(lbf-ft)	206/125.3 (151.9/62.4) [223/136 (164.5/100.3)]	
	Spindle Type	1st	-	BELT	
		2nd	-	BELT	
	Spindle Nose	1st	-	A2-6	A2-8
2nd		-	A2-6		
C-axis Indexing	deg	0.001°			
FEED	Travel	mm(in)	X1/Y1/Z1/X2/Y2/Z2/ZB : 165/100/700/165/100/700/730 (6.5"/3.9"/27.6"/6.5"/3.9"/27.6"/28.7")		
	Rapid Traverse Rate	m/min(ipm)	X1/Y1/Z1/X2/Y2/Z2/ZB : 20/10/36/20/10/36/36 (787/394/1,417/787/394/1,417/1,417)		
	Slide Type	X/Y	-	BOX GUIDE	
Z		-	ROLLER LM GUIDE		
TURRET	No. of Tools	ea	2×12 [2×24]		
	Tool Size	O.D/I.D mm(in)	□20 (□0.8")/Ø32 (Ø1.3")		
	Indexing Time	sec/step	0.2		
	Y-Axis Type	-	WEDGE TYPE		
LIVE TOOL	Motor (Max/Cont.)	r/min	5,000 [5,000]		
	Milling Tool Speed (rpm)	kW(HP)	5.5/3.7 (7.5/5) [7.5/1.5 (10/2)]		
	Torque (Max/Cont.)	N-m(lbf-ft)	52.5/26.5 (38.7/19.5) [47.7/16.9 (35.2/12.5)]		
	Collet Size	mm(in)	Ø16 (Ø0.6") {ER25}		
	Type	-	BMT55		
TANK CAPACITY	Coolant Tank	ℓ (gal)	320 (79.3)		
	Lubricating Tank	ℓ (gal)	4 (1.1)		
POWER SUPPLY	Electric Power Supply	kVA	46		
	Thickness of Power Cable	mm ²	OVER 50		
	Voltage	V/Hz	220/60 (200/50*)		
MACHINE	Floor Space (L×W)	mm(in)	3,815×2,224 (150.2"×87.6")	3,845×2,224 (151.4"×87.6")	
	Height	mm(in)	2,094 (82.4")		
	Weight	kg(lb)	9,000 (19,842)	9,000 (19,842)	
NC	Controller	-	FANUC i Series - Smart Plus [FANUC 31i-B Plus]		

*) Using 50Hz voltage instead of 60Hz may lower the output of motors. (excluding servo motors and inverter motors)
Specifications are subject to change without notice for improvement.

CONTROLLER

FANUC – Smart Plus

[] : Option

Controlled axis / Display / Accuracy Compensation	
Control axis	2 axis (X, Z) / 3 axis (X, Z, C) / 4 axis (X,Z,Y,C) 5 axis (X, Z, B, C, A) / 6 axis (X, Z, Y, B, C, A) 7 axis (X1/Z1, X2/Z2, B2, C1/C2)
Simultaneously controlled axis	2 axis [Max. 4 axis]
Designation of spindle axis	3 axis [Max. 4 axis]
Least setting Unit	X, Z, Y, B axis : 0.001 mm (0.0001 inch) C, A axis : 0.001 deg
Least input increment	X, Z, Y, B axis : 0.001 mm (0.0001 inch) C, A axis : 0.001 deg
Inch / Metric conversion	G20 / G21
High response vector control	
Interlock	All axis / Each axis
Machine lock	All axis
Backlash compensation	± 0~9999 pulses (exc. Rapid traverse / Cutting feed)
Position switch	
LCD / MDI	15 inch LCD unit (with Touch Panel)
Feedback	Absolute motor feedback
Stored stroke check 1	Over travel
Stored stroke check 2, 3	
PMC axis control	
Operation	
Automatic operation (Memory)	
MDI operation	
DNC operation	Needed DNC software / CF card
Program restart	
Wrong operation prevention	
Program check function	Dry run
Single block	
Search function	Program Number / Sequence Number
Interpolation functions	
Pano interpolation	
Positioning	G00
Linear interpolation	G01
Circular interpolation	G02, G03
Exact stop mode	Single : G09, Continuous : G61
Dwell	G04, 0 ~ 9999.9999 sec
Skip	G31
Reference position return	1st reference : G28, 2nd reference : G30 Ref. position check : G27
Thread synchronous cutting	G33
Thread cutting retract	
Variable lead thread cutting	
Multi / Continuous threading	
Feed function / Acc. & Dec. control	
Manual feed	Rapid traverse Jog : 0~2,000 mm/min (79 ipm) Manual handle : x1, x10, x100 pulses Reference position return
Cutting Feed command	Direct input F code
Feedrate override	0 ~ 200% (10% Unit)
Rapid traverse override	1%, F25%, 50%, 100%
Override cancel	
Feed per minute	G98
Feed per revolution	G99
Look-ahead block	1 block
Program input	
Tape Code	EIA / ISO
Optional block skip	9 ea
Program stop / end	M00, M01 / M02, M30
Maximum command unit	± 999,999.999 mm (± 99,999.9999 inch)
Plane selection	X-Y : G17 / Z-X : G18 / Y-Z : G19
Workpiece coordinate system	G52, G53, 6 pairs (G54 ~ G59)
Manual absolute	Fixed ON
Programmable data input	G10
Sub program call	10 folds nested
Custom macro	#100 ~ #199, #500 ~ #999
G code system	A, B/C
Programmable mirror image	G51.1, G50.1
G code preventing buffering	G4.1
Direct drawing dimension program	Including Chamfering / Corner R
Conversational Program	SmartGuide-i

Program input	
Multiple repetitive cycles	1, 11
Canned cycle for turning	
Auxiliary function / Spindle speed function	
Auxiliary function	M & 4 digit
Level-up M Code	High speed / Multi / Bypass M code
Spindle speed function	S & 5 digit, Binary output
Spindle override	0% ~ 150% (10% Unit)
Multi position spindle orientation	M19 (S##)
Rigid tapping	
Constant surface speed control	G96, G97
Tool function / Tool compensation	
Tool function	T & 2 digit + Offset 2 digit
Tool life management	
Tool offset pairs	128 pairs
Tool nose radius compensation	G40, G41, G42
Geometry / Wear compensation	
Direct input of offset measured B	
Editing function	
Part program storage size	5,120m (2MB)
No. of registerable programs	1,000 ea
Program protect	
Background editing	
Extended part program editing	Copy, move and change of NC program
Memory card program edit	
Data input / output & Interface	
I/O interface	CF card, USB memory Embedded Ethernet interface
Screen hard copy	
External message	
External key input	
External workpiece number search	
Automatic data backup	
Setting, display and diagnosis	
Self-diagnosis function	
History display & Operation	Alarm & Operator message & Operation
Run hour / Parts count display	
Maintenance information	
Actual cutting feedrate display	
Display of spindle speed / T code	
Graphic display	
Operating monitor screen	Spindle / Servo load etc.
Power consumption monitoring	Spindle & Servo
Spindle / Servo setting screen	
Multi language display	Support 24 languages
Display language switching	Selection of 5 optional Languages
LCD Screen Saver	Screen saver
Unexpected disturbance torque	BST (Back spin torque limit)
Function for machine type	
Cs contour control (C & A axis)	Mill, MS, Y, SY, LF-Mill, TTMS, TTSY
Polar coordinate interpolation	Mill, MS, Y, SY, LF-Mill, TTMS, TTSY
Cylindrical interpolation	Mill, MS, Y, SY, LF-Mill, TTMS, TTSY
Polygon turning (2 Spindles)	Mill, MS, Y, SY, LF-Mill, TTMS, TTSY
Canned cycle for drilling	Mill, MS, Y, SY, LF-Mill, TTMS, TTSY
Spindle orientation expansion	MS, SY TTS, TTMS, TTSY
Spindle synchronous control	MS, SY TTS, TTMS, TTSY
Torque control	MS, SY TTS, TTMS, TTSY
Y axis offset	Y, SY, TTSY
Arbitrary angular control	Y, SY, TTSY
Composite / Superimposed control	MS, SY, TTS, TTMS, TTSY
Balance cutting	TTS, TTMS, TTSY
Option	
Fast ethernet	Needed option board
Data server	Needed option board
Protection of data at 8 levels	
Tool offset pairs	200 pairs
Helical interpolation	
Optional block skip	40 ea, 200 ea (AICC 11)

Figures in inch are converted from metric values.

The FANUC controller specifications are subject to change based on the policy of company CNC supplying.

CONTROLLER

FANUC 31i-B Plus

[] : Option

Controlled axis / Display / Accuracy Compensation	
Control axis	4 axis (X, Z, Y, C) / 6 axis (X, Z, Y, B, C, A) 7 axis (X1/Z1, X2/Z2, B2, C1/C2) 8 axis (X1/Z1, X2/Z2, Y1, B2, C1/C2)
Simultaneously controlled axis	2 axis [Max. 4 axis]
Designation of spindle axis	4 axis (1 path), 6 axis (2 path Total)
Least setting Unit	X, Z, Y, B axis : 0.001 mm (0.0001 inch) C, A axis : 0.001 deg
Least input increment	X, Z, Y, B axis : 0.001 mm (0.0001 inch) C, A axis : 0.001 deg
Inch / Metric conversion	G20 / G21
High response vector control	
Interlock	All axis / Each axis
Machine lock	All axis
Backlash compensation	± 0 ~ 9999 pulses (Rapid traverse / Cutting feed)
Position switch	
LCD / MDI	15 inch color LCD
Feedback	Absolute motor feedback
Stored stroke check 1	Over travel
Stored stroke check 2, 3	
PMC axis control	
Operation	
Automatic operation (Memory)	
MDI operation	
DNC operation	Needed DNC software / CF card
Program restart	
Wrong operation prevention	
Program check function	Dry run, Program check
Single block	
Search function	Program Number / Sequence Number
Interpolation functions	
Pano interpolation	
Positioning	G00
Linear interpolation	G01
Circular interpolation	G02, G03
Helical interpolation	
Exact stop mode	Single : G09, Continuous : G61
Dwell	G04, 0 ~ 9999.9999 sec
Skip	G31
Reference position return	1st reference : G28 / 2nd reference : G30 Ref. position check : G27
Thread synchronous cutting	
Thread cutting retract	
Variable lead thread cutting	
Multi / Continuous threading	
Feed function / Acc. & Dec. control	
	Rapid traverse
Manual feed	Jog : 0~2,000 mm/min (79 ipm) Manual handle : x1, x10, x100 pulses Reference position return
Cutting Feed command	Direct input F code
Feedrate override	0 ~ 200% (10% Unit)
Rapid traverse override	F1%, F25%, 50%, F100%
Override cancel	
Feed per minute	G98
Feed per revolution	G99
Look-ahead block	1 block
Program input	
Tape Code	EIA / ISO
Optional block skip	9 ea
Program stop / end	M00, M01 / M02, M30
Maximum command unit	± 999,999.999 mm (± 99,999.9999 inch)
Plane selection	X-Y : G17 / Z-X : G18 / Y-Z : G19
Workpiece coordinate system	G52, G53, 6 pairs (G54 ~ G59)
Manual absolute	Fixed ON
Programmable data input	G10
Sub program call	10 folds nested
Custom macro	#100 ~ #149, #500 ~ #549
G code system	A/B/C
Programmable mirror image	G51.1, G50.1
G code preventing buffering	G4.1
Direct drawing dimension program	Including Chamfering / Corner R

Program input	
Multiple repetitive cycles I, II	
Canned cycle for turning	
Manual Guide i	Conversational auto program
Auxiliary function / Spindle speed function	
Auxiliary function	M 4 digit
Level-up M Code	High speed / Multi / Bypass M code
Spindle speed function	S 4 digit, Binary output
Spindle override	0% ~ 150% (10% Unit)
Multi position spindle orientation	M19
Rigid tapping	
Constant surface speed control	G96, G97
Tool function / Tool compensation	
Tool function	T 2 digit + Offset 2 digit
Tool life management	
Tool offset pairs	200 pairs
Tool nose radius compensation	G40, G41, G42
Geometry / Wear compensation	
Direct input of offset measured B	
Editing function	
Part program storage size	8M
No. of registerable programs	1000 ea
Program protect	
Background editing	
Extended part program editing	Copy, move and change of NC program
Memory card program edit	
Data input / output & Interface	
I/O interface	CF card, USB memory Embedded Ethernet interface
Screen hard copy	
External message	
External key input	
External workpiece number search	
Automatic data backup	
Setting, display and diagnosis	
Self-diagnosis function	
History display & Operation	Alarm & Operator message & Operation
Run hour / Parts count display	
Maintenance information	
Actual cutting feedrate display	
Display of spindle speed / T code	
Graphic display	
Operating monitor screen	Spindle / Servo load etc.
Power consumption monitoring	Spindle & Servo
Spindle / Servo setting screen	
Multi language display	Support 20 languages
Display language switching	Selection of 5 optional Languages
LCD Screen Saver	Screen saver
Unexpected disturbance torque	BST (Back spin torque limit)
Function for machine type	
Cs contour control (C & A axis)	Mill, MS, Y, SY, LF-Mill, TTMS, TTSY
Polar coordinate interpolation	Mill, MS, Y, SY, LF-Mill, TTMS, TTSY
Cylindrical interpolation	Mill, MS, Y, SY, LF-Mill, TTMS, TTSY
Polygon turning (2 Spindles)	Mill, MS, Y, SY, LF-Mill, TTMS, TTS
Canned cycle for drilling	Mill, MS, Y, SY, LF-Mill, TTMS, TTSY
Spindle orientation expansion	MS, SY TTS, TTMS, TTSY
Spindle synchronous control	MS, SY TTS, TTMS, TTSY
Torque control	MS, SY TTS, TTMS, TTSY
Y axis offset	Y, SY, TTSY
Arbitrary angular control	Y, SY, TTSY
Composite / Superimposed control	MS, SY TTS, TTMS, TTSY
Balance cutting	MS, SY TTS, TTMS, TTSY
Option	
Fast ethernet	Needed option board
Data server	Needed option board
Protection of data at 8 levels	
Dynamic graphic display	

Figures in inch are converted from metric values.

The FANUC controller specifications are subject to change based on the policy of company CNC supplying.