

SG WIA

Next-generation High-speed Compact Tapping Center

VZ40/45 Series

VZ40 | VZ45 | VZ40TD

Technical Leader

The tapping center VZ Series, designed by SG WIA with years of expertise and the latest technology, maximizes productivity while maintaining rigidity and accuracy.

		VZ40	VZ45	VZ40TD
Table Size (L×W)	mm(in)	650×400 (25.6"×15.7")	800×450 (31.5"×17.7")	2-650×400
Max. Load Capacity	kg(lb)	300 (661)		2-250
Spindle Taper	-	BBT30		
Spindle Speed	r/min	12,000 [15,000] [24,000]	[12,000] [15,000] [24,000] [12,000]	12,000 [12,000] [15,000]
Spindle Power (Max./Cont.)	kW[HP]	13/3.7 (17.4/5) [18/5.5 (24.1/7.4)]	[3.7/1.1 (5/1.5)] [14.1/4.1 (18.9/5.5)] [22.6/3.5 (30.3/4.7)] [5.5/3.7 (7.5/5.5)]	13/3.7 (17.4/5) [14.1/4.1 (18.9/5.5)] [14.1/4.1 (18.9/5.5)]
Number of Tools	EA	21 [14] [20, 24]		14 [21] [20, 24]
Travel (X/Y/Z)	mm(in)	550/400/300 (21.7"/15.7"/11.8") [550/400/480 (21.7"/15.7"/18.9")]	700/450/300 (29.5"/17.7"/11.8") [700/450/480 (29.5"/17.7"/18.9")]	520/400/330 (20.5"/15.7"/11.8") [520/400/460 (20.5"/15.7"/18.1")]
Rapid Traverse Rate (X/Y/Z)	m/min	56/56/56 (2,205/2,205/2,205)		48/48/48 [56/56/56]

[] : Option ■ : Twin Arm ■ : SIEMENS ■ : MITSUBISHI

Tapping Center with More Upgraded Quality & Performance

- Max. 24,000rpm direct connection high-speed main spindle application (VZ40/45)
- High performance double seal type LM guide applied (VZ40/45)
- Shortens non-cutting time with rapid feed (56m/min.)
- Servo motor is applied on the ATC to reduce tool change time
- Shortens setting time for materials with a dual table system (VZ40TD)
- Twin arm type ATC for automation system (Option)



01 VZ40/45

High Speed, Productivity & Compact Design – Tapping Center

High Precision Spindle

- Direct Spindle
- 12,000 [15,000/24,000] r/min
- Standard BBT #30

Table

- Table Size (L×W)
- VZ40 : 645×400 mm (25.4"×15.7")
- VZ45 : 800×450 mm (31.5"×17.7")-
- Max. Load Capacity : 300 kg (661.4 lb)

ATC & Magazine

- Turret Type : 21 [14 : MITSUBISHI] EA
- Twin Arm Type : 24 [20] EA

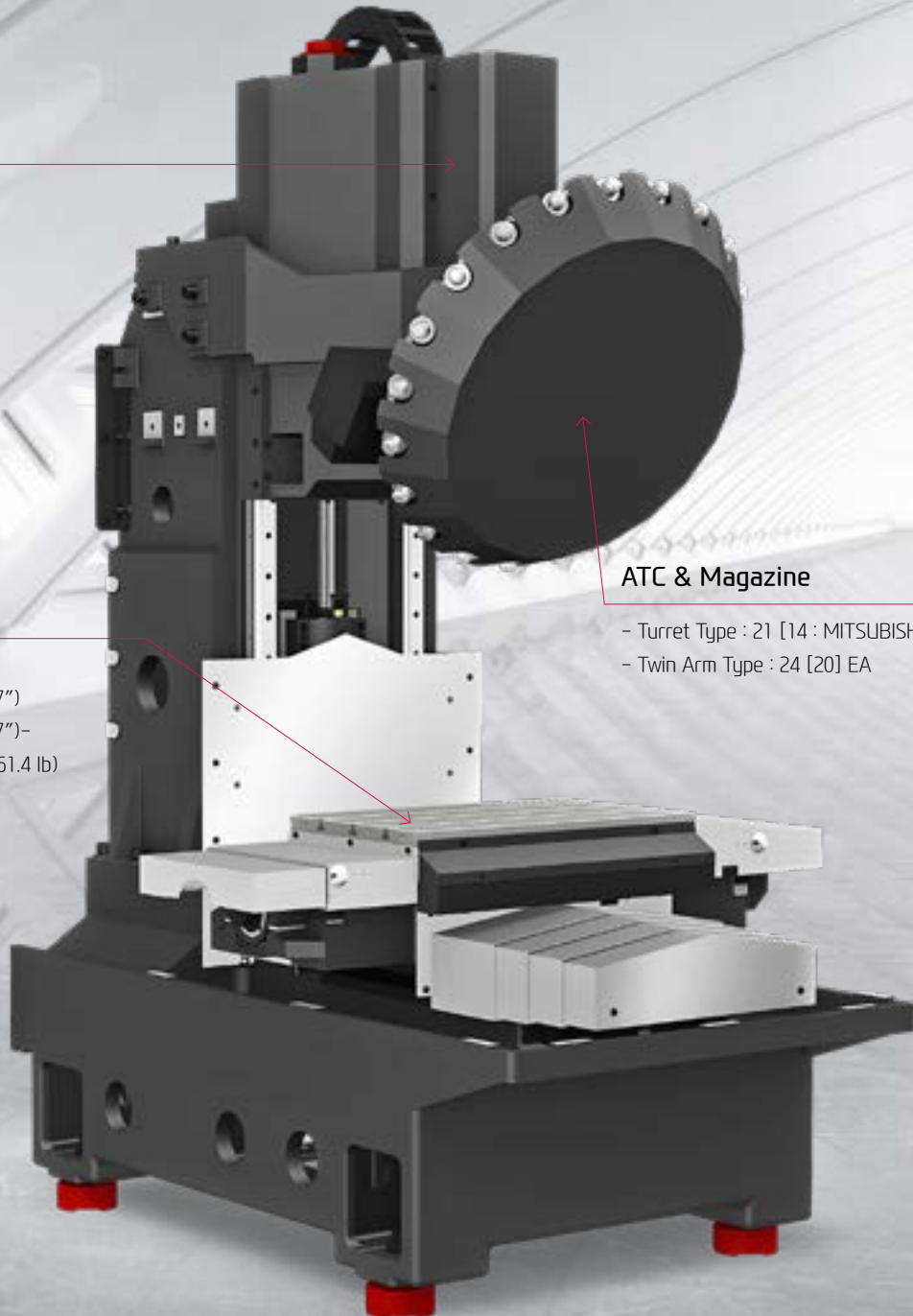

REDUCTION OF NON-CUTTING TIME BY FAST RAPID SPEED

OPTIMAL STRUCTURE FOR JIG

Optimal Structure for Automated Jig

Maximum height from top surface of the table to the main spindle nose has been increased from 480mm to 500mm, and you can secure sufficient machining area even when you apply the tools.

(Automated response of gantry loader available when using twin-arm ATC)

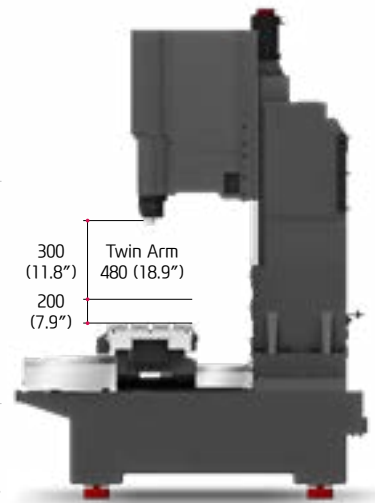

High Column

As an option, high columns with 150mm(5.9") and 300mm(11.8") is provided.

Turret Type (A~B)

200~500 mm (7.9"/19.7")

Twin Arm Type (A~B)

200~680 mm (7.9"/26.8")

GUIDEWAY

High-performance Double-seal Type LM Guide

Application of high-performance LM guide featuring double-seal attachment structure has significantly improved the durability of LM guide.

Ball Screw

Lubricating ball screw support bearings with oil helps improve the durability of the bearing.



High-speed Feed Capability

Model	Travel (X/Y/Z)	Rapid Traverse Rate (X/Y/Z)
VZ40	Turret : 550/400/300 mm (21.7"/15.7"/11.8")	56/56/56 m/min (2,205/2,205/2,205 ipm)
	Twin Arm : 550/400/480 mm (21.7"/15.7"/18.9")	
VZ45	Turret : 700/450/300 mm (27.6"/17.7"/13")	
	Twin Arm : 700/450/480 mm (27.6"/17.7"/18.9")	

02 VZ40TD

High Speed, Productivity & Compact Design – Dual-tabled Tapping Center

ATC & Magazine

- Turret Type : 14 [21] EA
- Twin Arm Type : 24 [20] EA

High Precision Spindle

- Direct Sp. : 12,000 [15,000] r/min
- Rigid Tapping : 6,000 r/min
- BBT #30

Dual Table

- Table Size (L×W) : 2-650×400 mm (25.6"×15.7")
- Max. Load Capacity : 2-250 kg (551.2 lb)
- Table Change Time : 6 sec

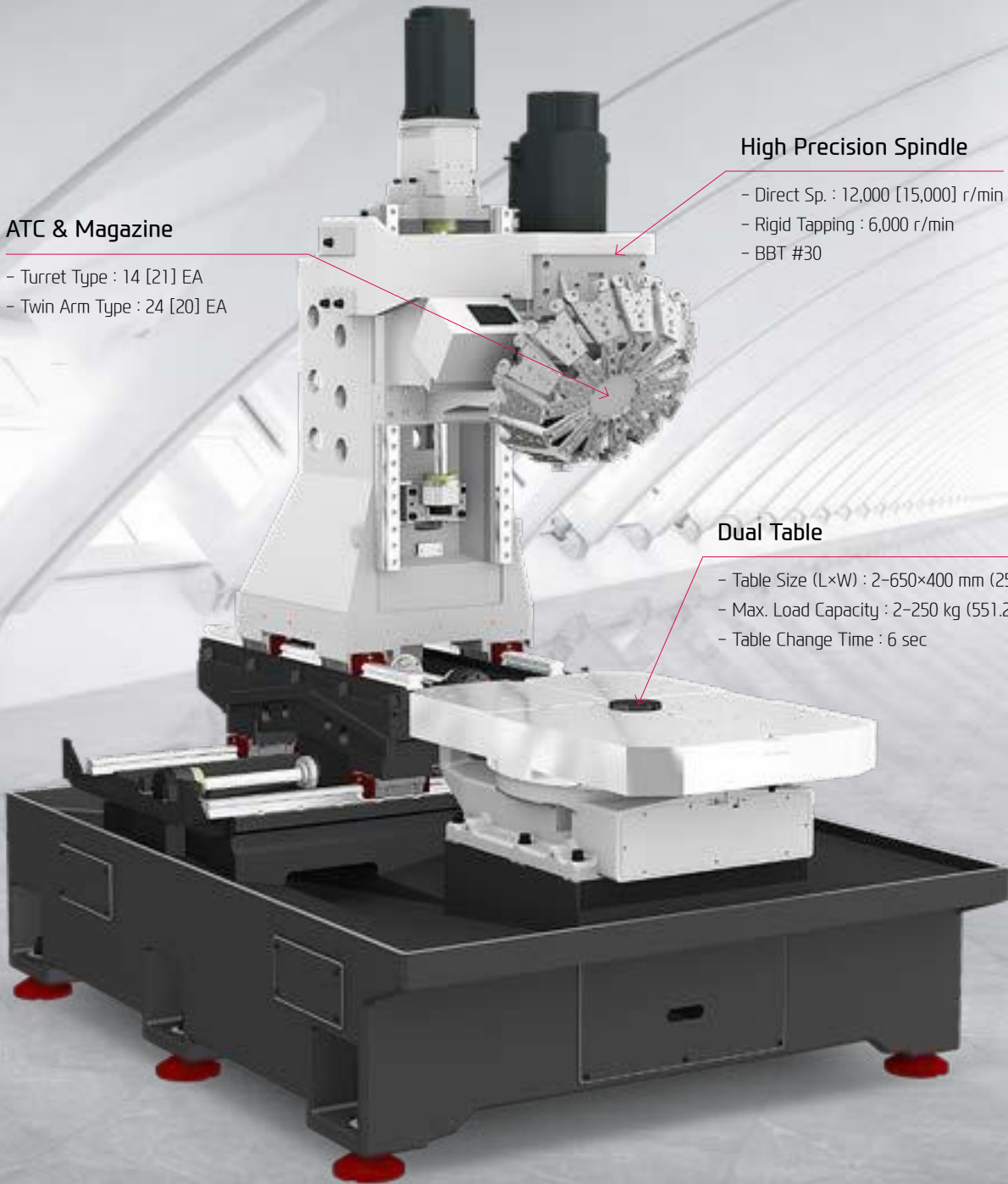

REDUCTION OF NON-CUTTING TIME BY FAST RAPID SPEED

COMPACT DESIGN

Column Moving Type

In order to utilize the dual table, column moving structure is adopted.

Also, extended column width and symmetrical heat behavior column structure allows accurate processing and minimized thermal displacement.

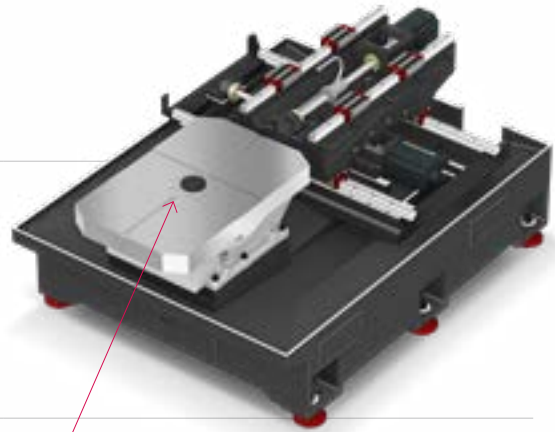

Dual Table Type Tapping Center

High productivity is achieved by the dual table which enables workers to setup a new workpiece while the machine is processing. Especially, the rotary table is designed for the simpler positioning by the location pin due to the application of hydraulic methods.

SLIDEWAY



LM Guideway

High speed axis movement is achieved by the use of LM guideways. This reduces non-cutting time and decreases machining time for greater productivity.

(Z-Axis : Roller LM Guide)



Ball Screw

The double anchored and pretensioned design provides outstanding positioning and repeatability with minimal thermal growth. Ball screws are connected directly to the servo motor to eliminate backlash.

Travel (X/Y/Z)

520/400/330 mm (20.5"/15.7"/13") [Twin Arm : 520/400/460 mm (20.5"/15.7"/18.1")]

Rapid Traverse Rate (X/Y/Z)

56/56/56 m/min (2,205/2,205/2,205 ipm) [FANUC, Twin Arm : 48/48/56 m/min (1,890/1,890/2,205 ipm)]

03 HIGH PRECISION SPINDLE

Long Lasting, High Accuracy &
Excellent Performance Tapping Center

Cutting Possibility

FACE MILL (Material : AL6061)

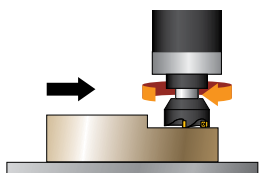
	Tool dia.	Ø63×5F
	Spindle speed	3,000 r/min
	Rapid feed rate	5,700 mm/min
	Cutting width	50 mm
	Cutting depth	4 mm
	Chip quantity	1,140 cc/min

DRILL (Material : AL6061)

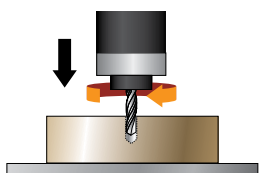
	Tool dia.	Ø30 (HSS)
	Spindle speed	795 r/min
	Rapid feed rate	159 mm/min
	Cutting width	30 mm
	Cutting depth	50 mm
	Chip quantity	113 cc/min

TAP (Material : AL6061)

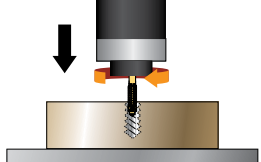
	Tool dia.	M27×P3.0
	Spindle speed	320 r/min
	Rapid feed rate	960 mm/min
	Cutting width	36 mm
	Chip quantity	54 mm

❖ The above results might be different based on your processing circumstances.

HIGH-PERFORMANCE, DIRECT DRIVEN SPINDLE

SPINDLE

Direct Spindle

The spindle is designed with angular contact ball bearings to increase rigidity, prevent thermal displacement. Due to the maximum spindle speed of 24,000rpm (VZ40/45), various types of machining is possible. While in reverse rotation, Double Speed Return function reduces processing time.

Spindle Air Purge Application

The main shaft motor cover prevents coolant from flowing into the head. In addition, by designing the spindle air purge through the spindle, the ability to remove chips from the spindle is improved.

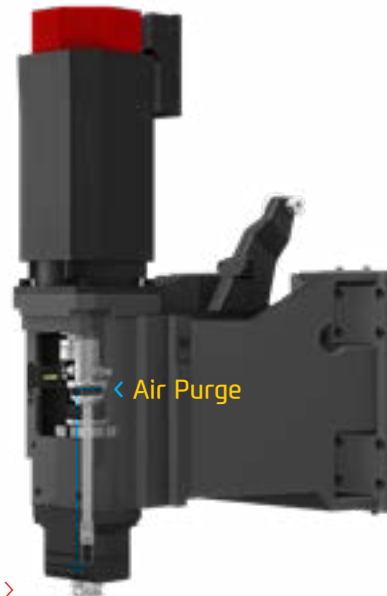

Spindle Thru Coolant **OPTION** (20/30/70 bar) >

Dual Contact Spindle

The Big Plus spindle system (BBT #30) provides dual contact between the spindle face and the flange face of the tool holder. This greatly increases tool rigidity, reduces run out and adds significant productivity to machining applications.

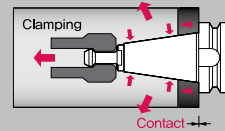

Direct Spindle Specifications

[] : Option ■ : FANUC ■ : SIEMENS ■ : MITSUBISHI

ITEM	Speed	Motor (Max./Cont.)	Torque (Max./Cont.)
VZ40 VZ40	12,000 rpm	13/3.7 kW (17.4/5 HP)	82.8/23.5 N·m (61/17.3 lbf·ft)
	[15,000 rpm]	[18.5/5.5 kW (25/7.5 HP)]	[57.35/17.5 N·m (42.3/2.9 lbf·ft)]
	[24,000 rpm]	[3.7/1.1 kW (5/1.5 HP)]	[11.8/3.5 N·m (8.7/2.6 lbf·ft)]
	[12,000 rpm]	[14.1/4.1 kW (18.9/5.5 HP)]	[45/21 N·m (33.2/15.5 lbf·ft)]
	[15,000 rpm]	[14.1/4.1 kW (18.9/5.5 HP)]	[45/21 N·m (33.2/15.5 lbf·ft)]
	[24,000 rpm]	[22.6/3.5 kW (30.3/4.7 HP)]	[24/3.7 N·m (17.7/2.7 lbf·ft)]
	[12,000 rpm]	[5.5/3.7 kW (7.5/4.7 HP)]	[18.8/12.6 N·m (13.9/9.3 lbf·ft)]
VZ40TD	12,000 rpm	13/3.7 kW (17.4/5 HP)	82.8/23.5 N·m (61/17.3 lbf·ft)
	[12,000 rpm]	[14.1/4.1 kW (18.9/5.5 HP)]	[45/21 N·m (33.2/15.5 lbf·ft)]
	[15,000 rpm]	[14.1/4.1 kW (18.9/5.5 HP)]	[45/21 N·m (33.2/15.5 lbf·ft)]

04 ATC & MAGAZINE

High Productivity Achieved with High Rigidity, Accuracy Machining



HIGH RIGIDITY, TOOL CHANGE SYSTEM

ATC & MAGAZINE

Turret Type ATC

Tool selection has been expanded by adopting a turret type magazine of 21 tools as a standard specification.
(VZ40TD : 14 tool)

Twin Arm Type ATC **OPTION**

The twin arm type ATC is configured as an option. In particular, the twin arm type ATC increases productivity with high machining capacity when configuring a gantry automation system.



Existing 14 tool → 21 tool increase

Servo Motor ATC

Servo motor is applied on the ATC to reduce tool change time. Also, accurate tool positioning control increases cutting stability.

Best-in-class Tool Change Time

It contributes to productivity improvement by reducing non-cutting time.

Previous Model	T-T	1.06 sec	
VZ40	T-T	1.0 sec	0.06 sec reduction
Previous Model	C-C	2.1 sec	
VZ40	C-C	1.8 sec	0.3 sec reduction

ATC & Magazine Specifications

[] : Option

Model	Po. of Tools	Max. Tool Length	Max. Tool Dia. (W.T/W.O)	Type
VZ40 VZ45	21 EA	240 mm (9.4")	Ø80/Ø80 mm (Ø3.1"/Ø3.1")	Turret
	[14] EA		Ø67/Ø125 mm (Ø2.6"/Ø4.9")	Twin Arm
	[20, 24] EA			
VZ40TD	14 [21] EA	200 mm (7.9")	Ø80/Ø80 mm (Ø3.1"/Ø3.1")	Turret
	[20] EA		Ø80/Ø125 mm (Ø3.1"/Ø4.9")	Twin Arm
	[24] EA			

05 USER CONVENIENCE

Various Devices for User Friendly

CHIP DISPOSAL SOLUTION & COOLANT UNIT

Improvement of Chip Disposal Capability

The chip disposal capability has been significantly improved compared to the previous equipment with standard application of two shower coolants, bed coolants, improvement of chip disposal tilt angle of the bed, and improvement of flood coolant position.

ITEM	VZ40/45	Previous Model
❶ Shower Coolant	Standard	Option
❷ Bed Flushing Coolant	Standard : 2EA	Non Applicable
❸ Flood Coolant	3 Locations on both sides of the equipment (Concentrated spraying on workpiece possible)	4 Locations at the bottom of the spindle (Concentrated spraying on workpiece possible)

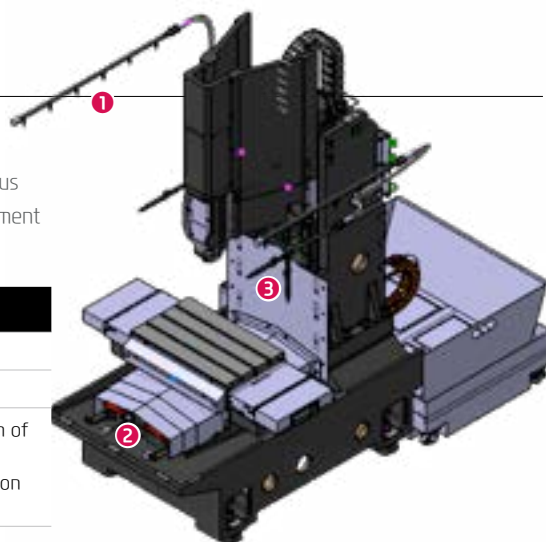

Chip Conveyor

Hinge	Chip Type : Roughing Chip, Long Chip, Chip complex	Material : SS41, 45C, Cast Steel	Rear Direction
	Highly efficient when disposing a lot of chips. Capable of handling stringy chips..		
Scraper	Chip Type : Finely broken chip blown out	Material : cast Iron, Nonferrous	
	Convenient for shortly cut chips.		
❖ Drum Filter	Chip Type : Powder, Micro Chip	Material : AL	
	Advantageous in precision, as the chips do not flow in to the coolant nozzle.		

❖ When ordering a drum filter chip conveyor, prior consult with hyundai wia's sales person.

HIGH-PRECISION SYSTEM



Touch Sensor

Workpiece coordinate values can be set automatically using the optional spindle probe.



TLM

Tool lengths and diameters can be set automatically using the optional tool setter. This can also be used to monitor attrition and detect broken tools.



NC Rotary Table

The NCRT makes it possible to machine up to 5-axis. Various types of products can be machined.

Optional



SG WIA
MACHINE TOOL

VZ series
Tapping Center

12
+
13

AUTOMATION SYSTEM

Gantry Loader System

Gantry loader transfers raw material from in-stocker to machine automatically, starting machining process. Gantry automation provides good equipment access during operation and easy work monitoring, program modification and maintenance. In addition, small installation area facilitates optimized factory layout.



Robot System

With its know-how and experience, SG WIA is globally recognized in the field of automation. Robot automation features flexible responsiveness, convenience and maintenance regardless of type for automation construction.



CREATING VALUE
IN SEAMLESS MOBILITY

06 FANUC – Smart Plus

The Compatible All-round Control



FANUC 0i Plus Series

- Customization functions are already included and offer an easy way to create HMI screens that are tailored to the application.
- The advantage being that existing programs can be used immediately and that new programs can be developed without the need for costly redundancies.
- Providing the high-performance offered by FANUC servo technology, this CNC also offers the same user-friendly convenience over the complete range.

10.4" Monitor as a Standard

Smart Machine Control	Fast Cycle Time Technology Fine Surface Technology
AI Contour Control	AICC-2 (200 blocks)
Smooth Tolerance Control	0.1µm command and specify tolerance
JERK Control	Diminished vibration by controlling acceleration speed
Machining Condition Selection	Designated machining level based on speed & quality
Machining Quality Control Function	Smooth Tolerance+ integrated support
Part Program Storage	5120M (2MB)
No. of Registerable Programs	1000 EA

MMS (Machine Monitoring System)



MMS Cloud

A cloud server-based equipment monitoring system for collecting and analyzing facility operation data.

Manufacturing big data solution with design, manufacturing, and intelligence technology of SG-WIA
(Big data collection/Analysis/Visualization)

SMART CNC (FANUC Smart Plus)



1. Dialogue Program (Smart Guide-i)

This software offers the maximum user convenience through dialogue manipulation from setup to processing. This includes writing processing programs and simulation checks.

2. LAUNCHER

This software offers shortcuts for quick access to specialized features and frequently used features.

Specifications

Standard & Optional

● : Standard ○ : Option ☆ : Prior Consultation - : Non Applicable

Spindle		VZ40	VZ45
12,000rpm (13kW)	FANUC	●	●
15,000rpm (15kW)	FANUC	○	○
24,000rpm (3.7kW)	FANUC	○	○
12,000rpm (14.1kW)	SIEMENS	○	○
15,000rpm (14.1kW)	SIEMENS	○	○
24,000rpm (22.6kW)	SIEMENS	○	○
12,000rpm (5.5kW)	MITSUBISHI	○	○
Spindle Cooling System (Fan Cooler)		-	-
ATC			
ATC Extension	14 (Turret)	○	○
	21 (Turret)	●	●
	20 (Twin Arm)	○	○
	24 (Twin Arm)	○	○
Tool Shank Type	BBT30	●	●
	BCV30	-	-
Pull Stud	45°	●	●
Table & Column			
T-Slote Pallet		●	●
NC Rotary Table		☆	☆
High Column	150mm (5.9")	○	○
	300mm (11.8")	○	○
Coolant System			
Std. Coolant (Nozzle)		●	●
Bed Flushing Coolant		●	●
Through Spindle Coolant*	20bar	○	○
	30bar	○	○
	70bar	○	○
Top Cover		●	●
Shower Coolant		●	●
Gun Coolant		○	○
Air Gun		○	○
Cutting Air Blow		○	○
Tool Measuring Air Blow (Only for TLM)		○	○
Air Blow for Automation		☆	☆
Thru MQL Device (Without MQL)		☆	☆
Coolant Chiller (Sub Tank)		☆	☆
Power Coolant System (For Automation)		☆	☆
Chip Disposal			
Coolant Tank	220 ℓ	●	●
Chip Conveyor (Hinge/Scraper)	Rear (Left)	○	○
	Rear (Right)	○	○
	Rear (Rear)	○	○
Special Chip Conveyor (Drum Filter)		☆	☆
Chip Wagon	Standard (180 ℓ)	○	○
	Swing (200 ℓ)	○	○
	Large Swing (290 ℓ)	○	○
	Large Size (330 ℓ)	○	○
	Customized	☆	☆
S/W			
Dialogue Program (HW-DPRO)		○	○
DNC software (HW-eDNC)		○	○
Machine Monitoring System (HW-MMS Cloud)		☆	☆
Smart Guide-i : FANUC		○	○
Smart S/W		☆	☆

Electric Device		VZ40	VZ45
Call Light	2 Color : ■ ■	●	●
Call Light & Buzzer	3 Color : ■ ■ ■ B	○	○
Work Light		●	●
Electric Cabinet Light		○	○
Remote MPG		-	-
Work Counter	Digital	○	○
Total Counter	Digital	○	○
Tool Counter	Digital	○	○
Multi Tool Counter	6 EA	☆	☆
	9 EA	☆	☆
Electric Circuit Breaker		○	○
AVR (Auto Voltage Regulator)		☆	☆
Transformer (380V : 20kVA)	FANUC	○	○
Transformer (220V : 25kVA)	SIEMENS	○	○
Auto Power Off		○	○
Measuring Device			
Air Zero	TACO	☆	☆
	SMC	☆	☆
Work Measuring Device		☆	☆
TLM (Marposs/Renishaw/Blum)	Touch	○	○
	Laser	○	○
Tool Broken Detective Device		☆	☆
Coolant Level Sensor (Only for Chip Conveyor, Bladder Type)		☆	☆
Environment			
Air Conditioner		○	○
Dehumidifier		○	○
Oil Mist Collector		☆	☆
Oil Skimmer (Only for Chip Conveyor)		○	○
MQL (Minimal Quantity Lubrication)		☆	☆
Fixture & Automation			
Auto Door		○	○
Sub O/P		☆	☆
NC Rotary Table/F	Single	○	○
	Channel	☆	☆
Control of Additional Axis		1Axis	○
External M Code 4ea		○	○
Automation Interface		☆	☆
I/O Extension (In & Out)	16 Contact	☆	☆
	32 Contact	☆	☆
Hyd. Device			
Hyd. Unit for Fixture	45bar	☆	☆
	70bar	☆	☆
	100bar	☆	☆
	Customized	☆	☆
ETC			
Tool Box		●	●
Customized Color	Need for Munsel No.	☆	☆
CAD&CAM Software		☆	☆

*Through Spindle Coolant : Please check the filter types with sales representative.

Specifications are subject to change without notice for improvement. / Please refer to the S/W catalog (IRIS) for details by S/W product.

Specifications

Standard & Optional

		VZ40TD
Spindle		
12,000rpm (FANUC)	Direct	●
15,000rpm (SIEMENS)	Direct	○
12,000rpm (SIEMENS)	Direct	-
Spindle Cooling System (Fan Cooler)		-
ATC		
ATC Extension	14 (Turret)	●
	21 (Turret)	○
	20 (Twin Arm)	○
	24 (Twin Arm)	○
Tool Shank Type	BBT30	●
	BBT40	-
U-Center	D'andrea	-
Pull Stud	45°	●
Table & Column		
Tap Type Pallet		●
T-Slote Pallet		○
NC Rotary Table		☆
High Column	150mm (5.9")	-
	300mm (11.8")	-
Coolant System		
Std. Coolant (Nozzle)		●
Bed Flushing Coolant		●
Through Spindle Coolant*	20bar (290 psi)	○
	30bar (435 psi)	○
Top Cover		○
Shower Coolant		○
Gun Coolant		○
Air Gun		○
Cutting Air Blow		○
Tool Measuring Air Blow (Only for TLM)		○
Air Blow for Automation		☆
Thru MQL Device (Without MQL)		☆
Coolant Chiller		☆
Power Coolant System (For Automation)		☆
Chip Disposal		
Coolant Tank	200 ℓ (52.8 gal)	●
	240 ℓ (63.4 gal)	-
Cabin Screw Chip Conveyor		-
Chip Conveyor (Hinge/Scraper)	Rear (Left)	○
	Rear (Right)	○
	Rear (Rear)	○
Special Chip Conveyor (Drum Filter)		☆
Chip Wagon	Standard (180 ℓ [47.5 gal])	○
	Swing (200 ℓ [52.8 gal])	○
	Large Swing (290 ℓ [76.6 gal])	○
	Large Size (330 ℓ [87.2 gal])	○
	Customized	☆
S/W		
Dialogue Program (HW-DPRO)		○
DNC software (HW-eDNC)		○
Machine Monitoring System (HW-MMS Cloud)		☆
Smart Guide-i : FANUC		○
Smart S/W		☆

● : Standard ○ : Option ☆ : Prior Consultation - : Non Applicable

		VZ40TD
Electric Device		
Call Light	2 Color : ● ●	●
Call Light & Buzzer	3 Color : ● ● ● B	○
Work Light		●
Electric Cabinet Light		○
Remote MPG		●
Work Counter	Digital	○
Total Counter	Digital	○
Tool Counter	Digital	○
Multi Tool Counter	6 EA	☆
	9 EA	☆
Electric Circuit Breaker		○
AVR (Auto Voltage Regulator)		☆
Transformer (380V : 20kVA)	FANUC	-
		○
Transformer (380V : 25kVA)		○
Transformer (220V : 25kVA)	SIEMENS	○
Auto Power Off		○
Measuring Device		
Air Zero	TACO	☆
	SMC	☆
Work Measuring Device		☆
TLM (Marposs/Renishaw/Blum)	*Touch Laser	○ ○
Tool Broken Detecting Device		☆
Coolant Level Sensor (Only for Chip Conveyor, Bladder Type)		☆
Environment		
Air Conditioner		○
Dehumidifier		○
Oil Mist Collector		☆
Oil Skimmer (Only for Chip Conveyor)		○
MQL (Minimal Quantity Lubrication)		☆
Fixture & Automation		
Auto Door		○
Sub O/P		☆
NC Rotary Table/F	Single	○
	Channel	☆
Control of Additional Axis	1Axis	○
External M Code 4ea		○
Automation Interface		☆
I/O Extension (In & Out)	16 Contact	☆
	32 Contact	☆
Hyd. Device		
Std. Hyd. Unit	45bar (652.7 psi) / 30 ℓ (7.9 gal)	●
Center Hyd. Supply Device	2x3 (6Port)	○
	2x5 (10Port)	○
Compact Center Hyd. Supply Device	2x4 (8Port)	○
Hyd. Unit for Fixture	45bar (652.7 psi)	☆
	70bar (1,015 psi)	☆
	100bar (1,450 psi)	☆
	Customized	☆
ETC		
Tool Box		●
Customized Color	Need for Munsel No.	☆
CAD&CAM Software		☆

*Through Spindle Coolant : Please check the filter types with sales representative.

*TLM-Touch : Technical consultation needed if there is a requirement of tool radius measurement in VZ40TD.

Specifications are subject to change without notice for improvement. / Please refer to the S/W catalog (IRIS) for details by S/W product.

Specifications

Spindle Output/Torque Diagram

12,000 rpm (FANUC)

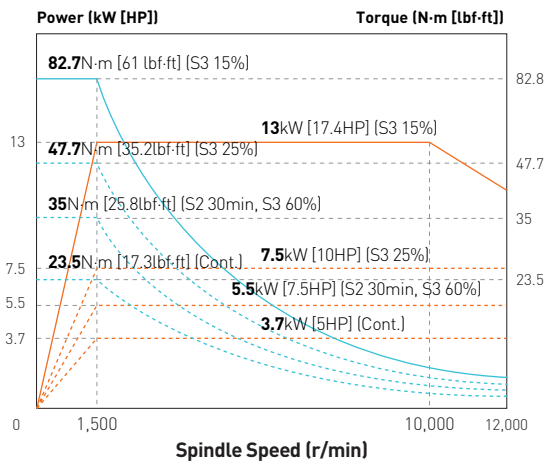

15,000 rpm (FANUC)

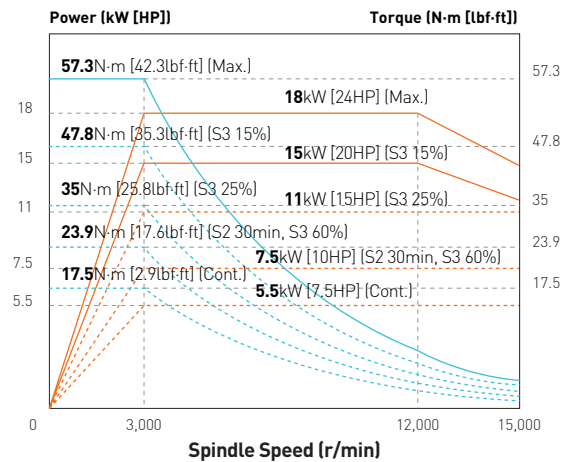

24,000 rpm (FANUC)

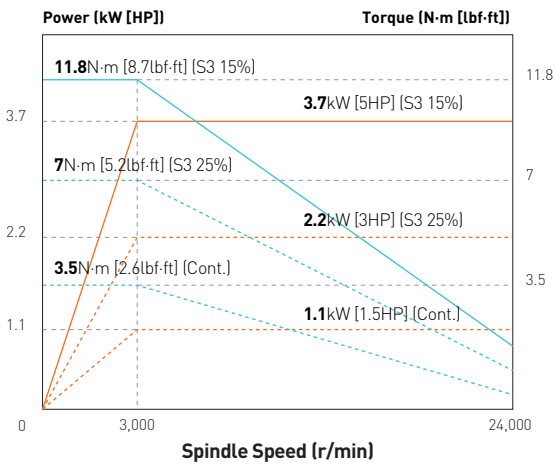

Specifications

Spindle Output/Torque Diagram

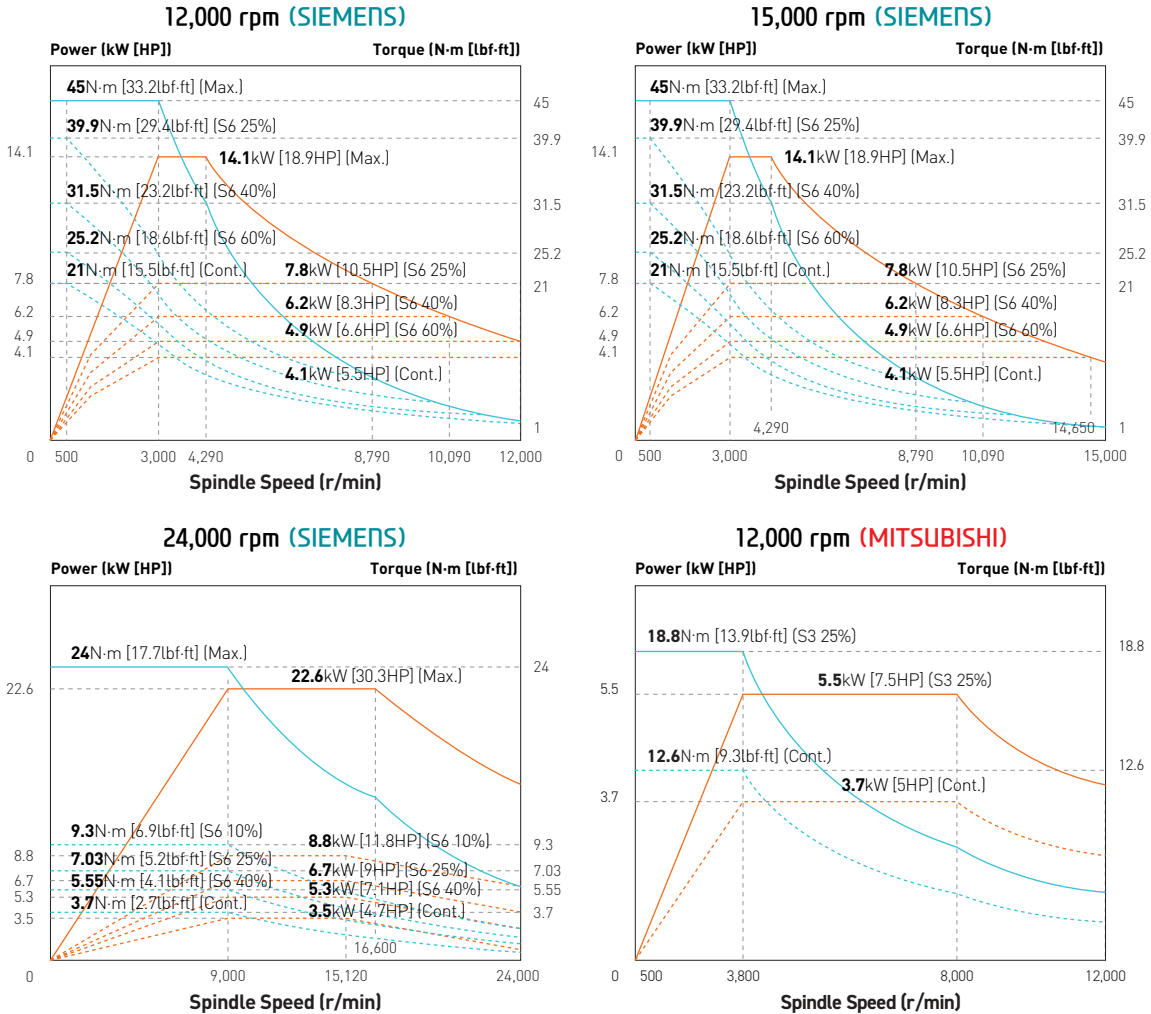

Specifications

External Dimensions

unit : mm(in)

VZ40

VZ45

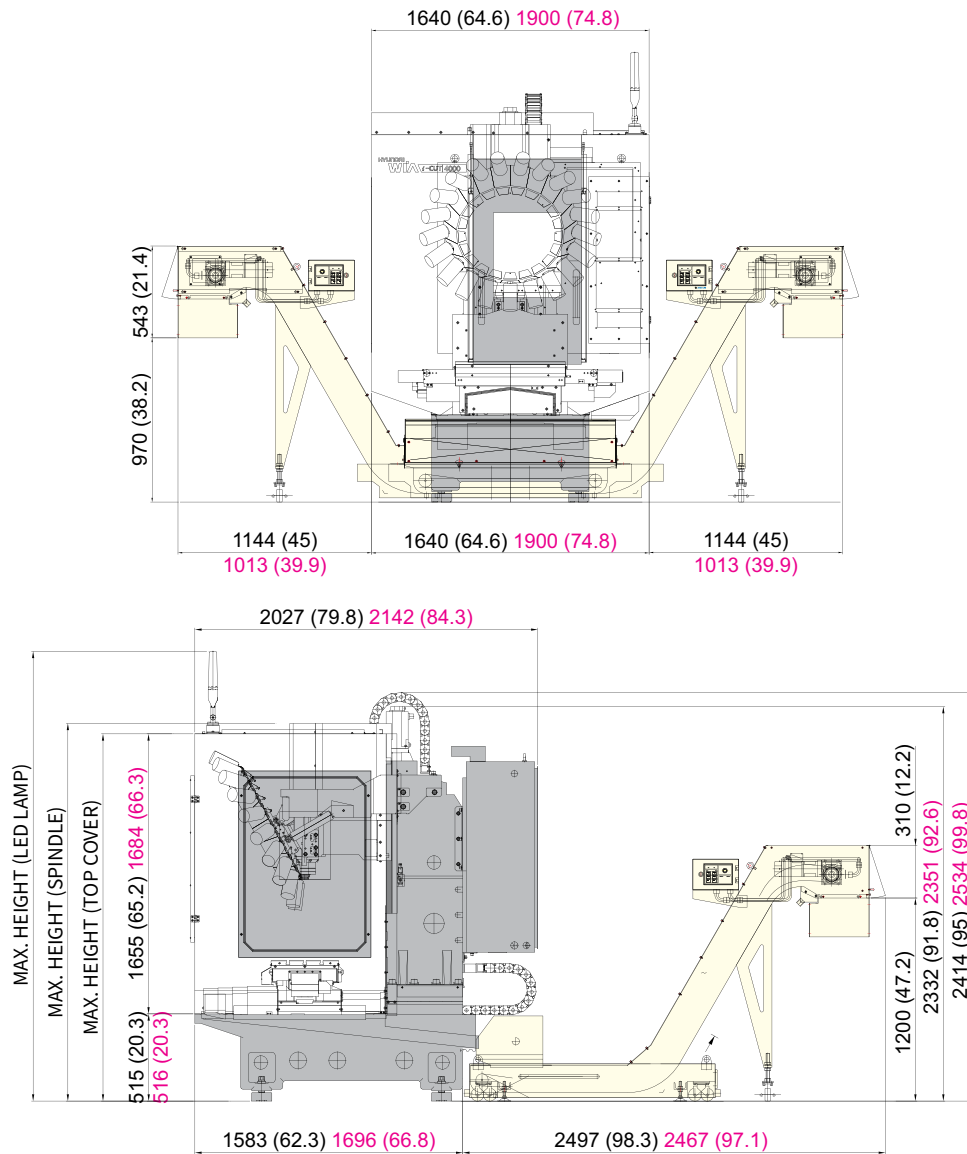

Model	Height Item	Max. Height (LED Lamp)		Max. Height (Top Cover)		Spindle Motor Height	
		Turret	Twin Arm	Turret	Twin Arm	Turret	Twin Arm
VZ40	Std. Column			2,170 (104.5)	2,602 (102.4)	2,400 (94.5)	2,580 (101.6)
	High Column 150mm	2,655 (104.5)		2,362 (93)	2,810 (110.6)	2,550 (100.4)	2,730 (107.5)
	High Column 300mm			2,472 (97.3)	2,920 (115)	2,700 (106.3)	2,880 (113.4)
VZ45	Std. Column			2,200 (86.6)	2,632 (103.6)	2,430 (95.7)	2,610 (102.8)
	High Column 150mm	2,685 (105.7)		2,392 (94.2)	2,840 (111.8)	2,580 (101.6)	2,760 (108.7)
	High Column 300mm			2,502 (98.5)	2,950 (116.1)	2,730 (107.5)	2,910 (114.6)

Specifications

External Dimensions

unit : mm

VZ40TD TwinArm Type

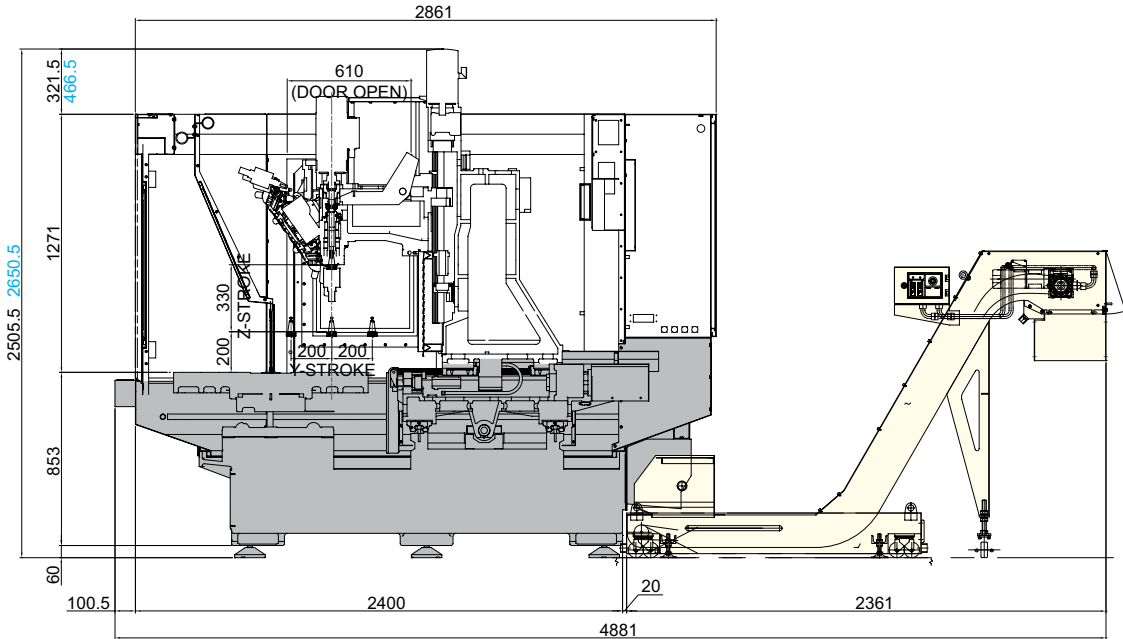
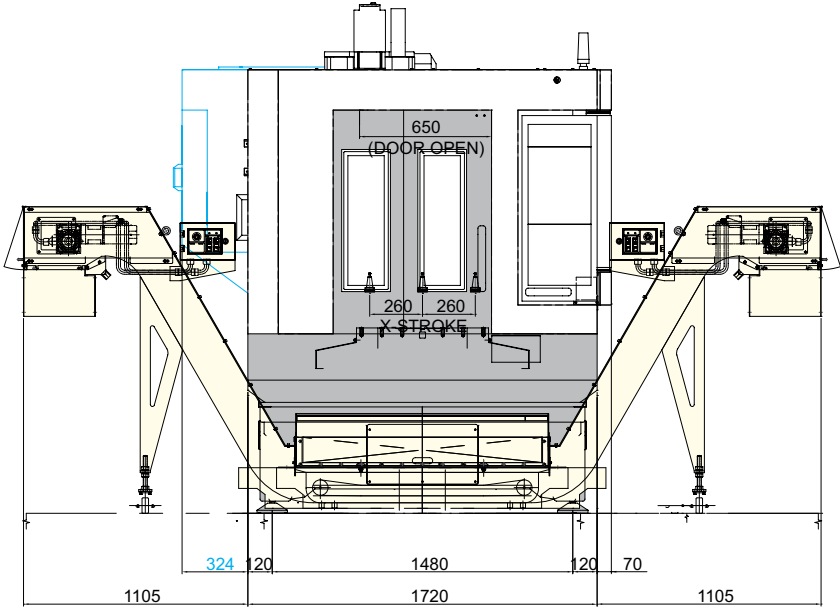

Specifications

Table Dimensions

unit : mm(in)

BBT 30

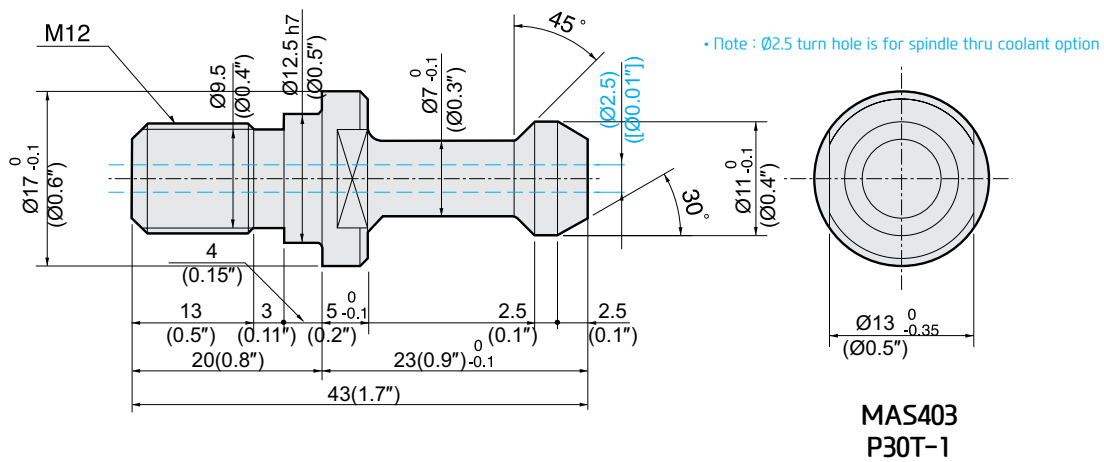
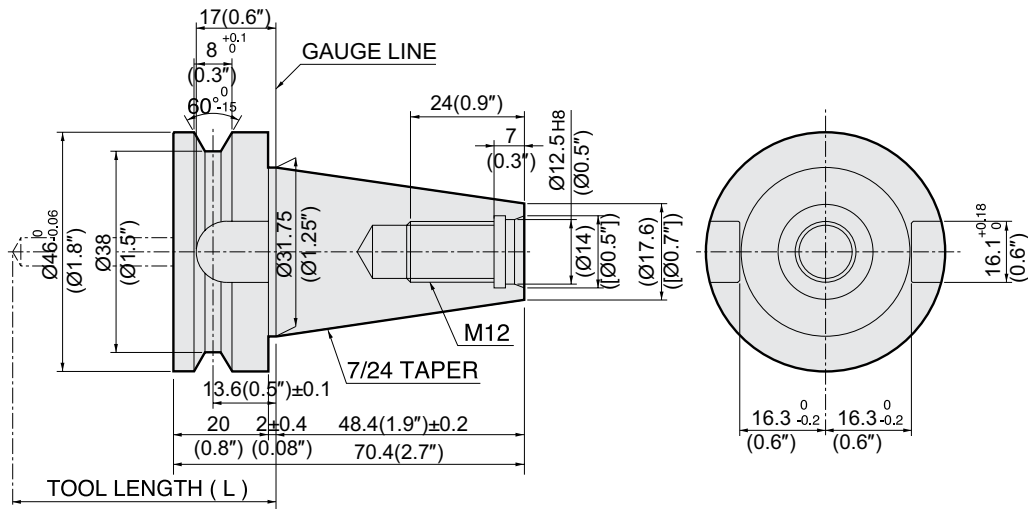

Specifications

Table Dimensions

unit : mm(in)

VZ40

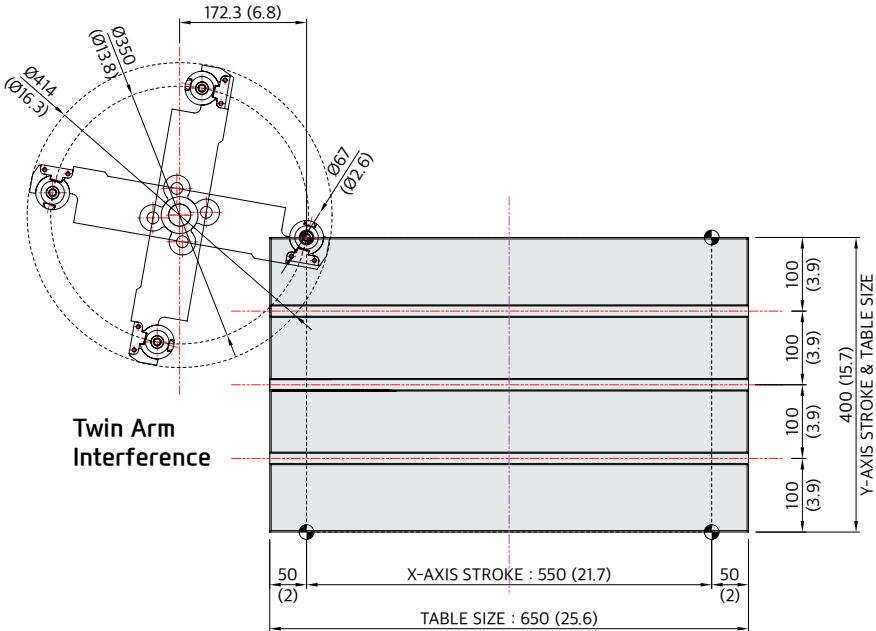

VZ45

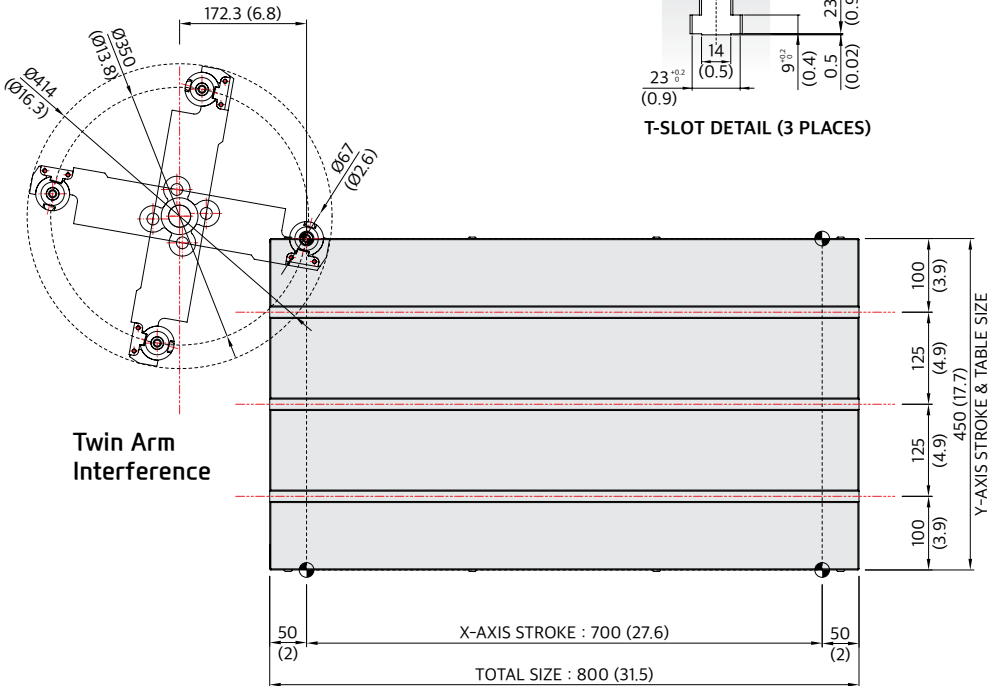

Specifications

Table Dimensions

unit : mm(in)

VZ40TD

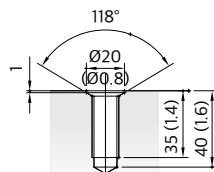
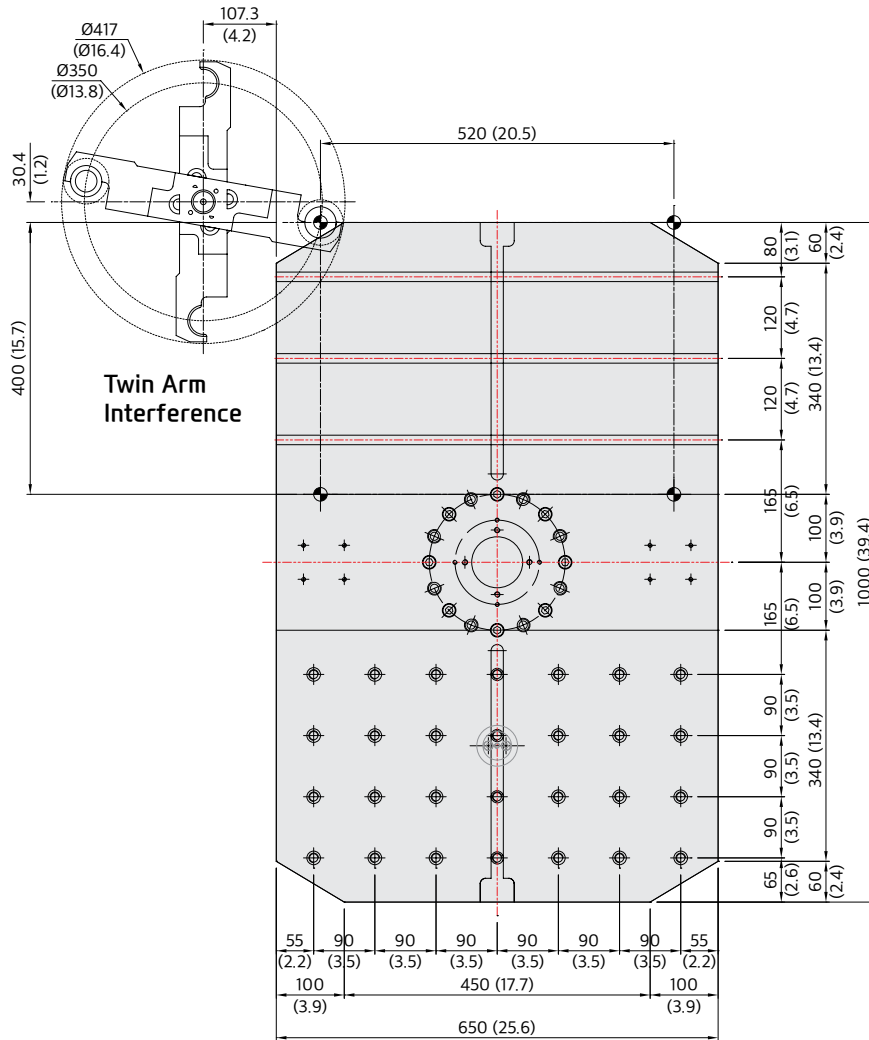

Tap Size
M16×2.0 (28EA)

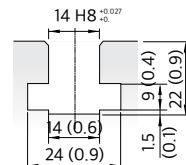

T-SLOT DETAIL

Specifications

Specifications

[] : Option ■ : SIEMENS ■ : MITSUBISHI

ITEM		VZ40	VZ45	
TABLE	Table Size (L×W)	mm(in) 650×400 (25.6"×15.7")	800×450 (31.5"×17.7")	
	Maximum Load Capacity	kg(lb)	300 (661.4)	
SPINDLE	Spindle Taper	-	BBT30	
	Spindle Speed (rpm)	r/min	12,000 [15,000] [24,000] [12,000] [15,000] [24,000] [12,000]	
	Power (Max./Cont.)	kW(HP)	13/3.7 [18/5.5] [3.7/1.1] [14.1/4.1] [14.1/4.1] [22.6/3.5] [5.5/3.7] [17.4/5] [24/7.5] [5/1.5] [18.9/5.5] [18.9/5.5] [30.3/4.7] [7.5/5]	
	Torque (Max./Cont.)	N·m(lbf·ft)	82.7/23.5 [57.3/17.5] [11.8/3.5] [45/21] [45/21] [24/3.7] [18.8/12.6] [61/17.3] [42.3/2.9] [8.7/2.6] [33.2/15.5] [33.2/15.5] [17.7/2.7] [13.9/9.3]	
	Spindle Driving Method	-	Direct	
FEED	Travel (X/Y/Z)	mm(in) 550/400/300 (21.7"/15.7"/11.8") [Twin Arm : 550/400/480 (21.7"/15.7"/18.9")]	700/450/300 (27.6"/17.7"/11.8") [Twin Arm : 700/450/480 (27.6"/17.7"/18.9")]	
	Distance from Table Top to SP. Nose	mm(in)	200 ~ 500 (7.9"~19.7") [Twin Arm : 680 (26.8")]	
	Distance from Z-axis Slide Cover to Sp. Center	mm(in)	467 (18.4")	487 (19.2")
	Rapid Traverse Rate (X/Y/Z)	m/min(ipm)	56/56/56 (2,205/2,205/2,205)	
	Slide Type	-	LM Guide	
ATC	Tool Shank	-	BBT30	
	Number of Tools	ea	21 [14] [Twin Arm : 20, 24]	
	Max. Tool Dia. (W.T / W.O)	mm(in)	Ø80/Ø80 (Ø3.1"/Ø3.1") [Twin Arm : Ø67/Ø125 (Ø2.6"/Ø4.9")]	
	Max. Tool Length	mm(in)	240 (9.4")	
	Max. Tool Weight	kg(lb)	3 (6.6)	
	Tool Selection Method	-	Fixed [Twin Arm : Random]	
	Tool Change Time	T-T C-C	sec	1.0 [1.2] [Twin Arm : 1.1] 1.8 [2.0] [Twin Arm : 2.5]
TANK CAPACITY	Coolant Tank	ℓ(gal)	220 (58.1)	
	Lubricating Tank	ℓ(gal)	2 (0.5)	
	Air Consumption 0.5MPa	ℓ/min	200 (52.8)	
POWER SUPPLY	Electric Power Supply	kVA	16 [19]	
	Thickness of Power Cable	mm ²	Over 25	
	Voltage	V/Hz	*220/60 (50) [380/60 (50)]	
MACHINE	Floor Space (L×W)	mm(in)	1,640×2,027 (64.6"×79.8")	1,900×2,142 (74.8"×84.3")
	Height	mm(in)	2,655 (104.5")	2,685 (105.7")
	Weight	kg(lb)	2,600 (5,732)	3,500 (7,716)
CNC	Controller	-	FANUC i Series - Smart Plus [SIEMENS 828D] [MITSUBISHI M80]	

◆ Tool change time is subject to tool weight. *) Using 50Hz voltage instead of 60Hz may lower the output of motors. (excluding servo motors and inverter motors)
Specifications are subject to change without notice for improvement.

Specifications

Specifications

[] : Option ■ : SIEMENS

ITEM		VZ40TD	
TABLE	Table Size (L×W)	mm(in)	2-650×400 (25.6"×15.7")
	Maximum Load Capacity	kg(lb)	2-250 (551.2)
	Table Change Time		6
	Change Method		ROTARY TURN
	Table Driving Method		ROTARY CYLINDER
SPINDLE	Spindle Taper	-	BBT30
	Spindle Speed (rpm)	r/min	12,000 [12,000] [15,000]
	Power (Max./Cont.)	kW(HP)	13/3.7 (17.4/5) [14.1/4.1(18.9/5.5)] [14.1/4.1(18.9/5.5)]
	Torque (Max./Cont.)	N·m(lbf·ft)	82.7/23.5 (61/17.4) [45/21 (33.2/15.5)] [45/21 (33.2/15.5)]
	Spindle Driving Method	-	Direct
FEED	Travel (X/Y/Z)	mm(in)	520/400/330 (20.5"/15.7"/13") [Twin Arm : 520/400/330 (20.5"/15.7"/18.1")]
	Distance from Table Top to SP. Nose	mm(in)	200 ~ 530 (7.9"~20.9") [Twin Arm : 200~660 (7.9"~26")]
	Distance from Z-axis Slide Cover to Sp. Center	mm(in)	484 (19")
	Rapid Traverse Rate (X/Y/Z)	m/min(ipm)	48/48/48 (1,890/1,890/1,890) [56/56/56 (2,205/2,205/2,205)]
	Slide Type	-	X/Y-Axis : LM GUIDE, Z-Axis : Roller LM Guide
ATC	Tool Shank	-	BBT30
	Number of Tools	ea	14 [21] [Twin Arm : 20, 24]
	Max. Tool Dia. (W.T / W.O)	mm(in)	Ø80/Ø80 (Ø3.1"/Ø3.1") [Twin Arm 20T : Ø80/125 (Ø3.1"/Ø4.9")] [Twin Arm 24T : Ø67/125 (Ø2.6"/Ø4.9")]
	Max. Tool Length	mm(in)	200 (7.9")
	Max. Tool Weight	kg(lb)	3 (6.6)
	Tool Selection Method	-	Fixed [Twin Arm : Random]
	Tool Change Time	T-T	sec
C-C		sec	1.8 [21 Tool : 2.1] [Twin Arm : 2.5] [1.6] [21 Tool : 1.8]
TANK CAPACITY	Coolant Tank	ℓ(gal)	210 (55.5)
	Lubricating Tank	ℓ(gal)	2 (0.5)
	Air Consumption	0.5MPa ℓ/min	200 (52.8)
POWER SUPPLY	Electric Power Supply	KVA	18 [20]
	Thickness of Power Cable	mm ²	Over 25
	Voltage	V/Hz	*220/60 (50) [380/60 (50)]
MACHINE	Floor Space (L×W)	mm(in)	1,720,861 (67.7"×116.5") [Twin Arm : 2,114×2,861 (83.2"×112.6")]
	Height	mm(in)	2,446 (96.3") [Twin Arm : 2,650 (104.3")]
	Weight	kg(lb)	4,800 (10,582)
CNC	Controller	-	SIEMENS 828D [FANUC i Series - Smart Plus]

◆ Tool change time is subject to tool weight. *) Using 50Hz voltage instead of 60Hz may lower the output of motors. (excluding servo motors and inverter motors)
Specifications are subject to change without notice for improvement.

Controller

FANUC i Series – Smart Plus

[] : Option ☆ Needed technical consultation

Controlled axis / Display / Accuracy Compensation	
Control axis	3 axis (X, Y, Z) [4 axis (X, Y, Z, A)] [5 axis (X, Y, Z, A, C)]
Simultaneously controlled axis	3 axis [Max. 4 axis]
Least setting Unit	X, Y, Z axis : 0.001 mm (0.0001 inch) B axis : 1 deg [0.001] deg
Least input increment	X, Y, Z axis : 0.001 mm (0.0001 inch) B axis : 1 deg [0.001] deg
Inch / Metric conversion	
High response vector control	
Interlock	All axis / Each axis
Machine lock	All axis
Backlash compensation	± 0 ~ 9999 pulses (Rapid traverse / Cutting feed)
Position switch	
LCD / MDI	10.4 inch LCD
Feedback	Absolute motor feedback
Stored stroke check 1	Over travel
Stored stroke check 2, 3	
Stored pitch error compensation	
Operation	
Automatic operation (Memory)	
MDI operation	
DNC operation	Needed DNC software / CF card
Program restart	
Wrong operation prevention	
Program check function	Dry run, Program check, Z axis Machine lock Stored limit check before move
Single block	
Search function	Program Number / Sequence Number
Handle interruption	
Interpolation functions	
Nano interpolation	
Positioning	G00
Linear interpolation	G01
Circular interpolation	G02, G03
Exact stop mode	Single : G09, Continuous : G61
Dwell	G04, 0 ~ 9999.9999 sec
Skip	G31
Reference position return	1st reference, G28 / 2nd reference, G30 Ref. position check, G27
Single direction positioning	G60
Thread synchronous cutting	G33
Helical interpolation	Circular + Linear 2 axis (Max.)
Feed function / Acc. & Dec. control	
Manual feed	Rapid traverse Jog : 0~2,000mm/min (79 ipm) Manual handle : x1, x10, x100 pulses Reference position return
Cutting Feed command	Direct input F code
Feedrate override	0 ~ 200% (10% Unit)
Rapid traverse override	1%, 25%, 50%, 100%
Override cancel	
Feed per minute	G94
Feed per revolution	G95
Cylindrical interpolation	G07.1
Inverse time feed	G93
Look-ahead block	200 blocks (AI APC)
Program input	
Tape Code	EIA / ISO
Optional block skip	9 ea
Absolute / Incremental program	G90 / G91
Program stop / end	M00, M01 / M02, M30
Maximum command unit	± 999,999.999 mm (± 99,999.9999 inch)
Plane selection	X-Y, G17 / Z-X, G18 / Y-Z, G19
Workpiece coordinate system	G52, G53, 48 pairs (G54.1 P1 ~ 48)
Manual absolute	Fixed ON
Programmable data input	G10
Sub program call	10 folds nested
Custom macro	#100 ~ #199, #500 ~ #999
Programmable mirror image	G51.1, G50.1
G code preventing buffering	G4.1
Optional chamfering corner R	

Program input	
Polar coordinate command	G15, G16
Canned cycle	G73, G74, G76, G80 ~ G89
Scaling	G50, G51
Coordinate system rotation	G68, G69
Auxiliary function / Spindle speed function	
Level-up M Code	Multi / Bypass M code
Spindle speed function	S & 5 digit , Binary output
Spindle override	0% ~ 150% (10% Unit)
Spindle orientation	M19
Retraction for rigid tapping	
FSSB high speed rigid tapping	
Tool function / Tool compensation	
Tool function	Max. T8 digit
Tool life management	
Tool offset pairs	400 pairs
Tool nose / radius compensation	G40, G41, G42
Tool length offset	G43, G44, G49
Tool offset memory C	Tool geometry and wear (Cutter and tool length)
Tool length measurement	Z axis Input C
Editing function	
Part program storage size	5,120m (2MB)
No. of registerable programs	1,000 ea
Program protect	
Background editing	
Extended part program editing	Copy, move and change of P/C program
Memory card program edit	
Data input / output & Interface	
I/O interface	CF card, USB memory Embedded Ethernet interface
Screen hard copy	
External message	
External key input	
External workpiece number search	
Automatic data backup	
Setting, display and diagnosis	
Self-diagnosis function	
History display & Operation	Alarm & Operator message & Operation
Run hour / Parts count display	
Maintenance information	
Actual cutting feedrate display	
Display of spindle speed / T code	
Graphic display	
Operating monitor screen	Spindle / Servo load etc.
Power consumption monitoring	Spindle & Servo
Spindle / Servo setting screen	
Multi language display	Support 24 languages
Display language switching	Selection of 5 optional Languages
LCD Screen Saver	Screen saver
Option	
Fast ethernet	Needed option board
Data server	Needed option board
Protection of data at 8 levels	
Additional Axis	
Manual handle feed	2/3 units
Addition of custom macro	#100~#199, #500~#999, #98000~#98499
Add. Workpiece	Max. 300 pairs (G54.1 P1 ~ P300)
AICC II	400 blocks ☆
Conversational Program	Smart Guide-i

Figures in inch are converted from metric values.

The FANUC controller specifications are subject to change based on the policy of company CNC supplying.

Controller

SIEMENS 828D

[] : Option ☆ Needed technical consultation

Controlled axis / Display / Accuracy Compensation	
Control axis	3 axis (X, Y, Z) [4 axis (X, Y, Z, A)] [5 axis (X, Y, Z, A, C)]
Simultaneously controlled axis	Max. 4 axis
Least setting Unit	X, Y, Z axis : 0.001 mm (0.0001 inch) [A, C (B) axis : 1 deg [0.001] deg]
Least input increment	X, Y, Z축 : 0.001 mm (0.0001 inch) [A, C (B) axis : 1 deg [0.001] deg]
Inch / Metric changeover	G70 (inch) / G71 (metric)
Interlock	All axis / Each axis
Pitch error compensation	
Feedforward control	
LCD / MDI	10.4 inch color LCD [15 inch color LCD (With Touch panel)]
Keyboard	QWERTY full keyboard
Stored stroke check	Over travel
Operation	
Automatic operation	
MDI operation	
Program restart	
Program check function	Dry run / Program check / Machine lock
Single block	
Block search	Block search
Reposition	
Working area limit	Working area limitations
Interpolation functions	
Positioning	G00
Linear interpolation	G01
Circular interpolation	Circular Interpolation CW (G02) Circular Interpolation CCW (G03)
Exact position stop	Single block exact stop (G09) Exact stop G60 (G601, G602, G603)
Dwell	Dwell (G04)
Reference position return	Return to reference point Return to 2nd reference point
Helical interpolation	
Spline interpolation	Non-uniform rational B splines
Compressor for 3-axis machining (Improving machining quality)	CompCAD / CompCURV (Cycle 832)
Feed function / Acc. & Dec. control	
Manual feed	Rapid traverse Jog Manual handle Reference position return
Cutting Feed command	Direct input F code
Feedrate override	0 ~ 200% (10% Unit)
Rapid traverse override	1%, 25%, 50%, 100%
Feed per minute	G94
Feed per revolution	G95
Look-ahead block	300 block 450 block : (SW28X Mold) [600 block]
Program input	
ISO correspondence	G291(ISO)/G290 (ISO G Code system-A)
Optional block skip	2
Program stop / end	M00, M01 / M02, M30
Maximum command unit	± 999,999.999 mm, ± 99,999.9999 inch
Plane selection	X-Y : G17, X-Z : G18, Y-Z : G19 G54 ~ G57, G505~G549
Workpiece coordinate system	G500 (Basic frame - settable zero offset) G53 (Work offset non modal) G153 (basic frame non modal)
Sub program call	11 folds nested
G code preventing buffering	STOPRE
Drilling/Milling cycle	Programing (Cycle 82, 83, 84, 840)
User cycle	

Auxiliary function / Spindle speed function	
Auxiliary function	M Code 4 digit
Spindle speed function	S Code 5 digit
Spindle override	0% ~ 150% (10% Unit)
Spindle orientation	SPOS
Rigid tapping	
Automatic mode Interchange	Spindle / Axis mode
Constant surface speed control	G96, G97
Spindle speed limitation	LIMS
Tool function / Tool compensation	
Tool function	Tool number & Tool name Tool : T + Offset : D
Tool life management	
Tools in tool list	256 ea 768 ea : (SW28X Mold)
Cutting Edges in tool list	512 ea 1,536 ea : (SW28X Mold)
Tool radius compensation	ISO (G40, G41, G42)
Tool length offset	
Geometry / Wear compensation	
Measurement of tool length	
Tool management function	
Editing function	
Part program storage size	5MB 10MB : (SW28X Mold)
No. of registerable programs	750 ea
External Storage devices	Local network, Server, USB, Flash drive
Background editing	
Extended part program editing	Copy, move and change of NC program
Memory card program edit	
Data input / output & Interface	
I/O interface	CF card interface (ONLY 10.4") USB memory interface Embedded Ethernet memory interface
Screenshot	
Setting, display and diagnosis	
Self-diagnosis function	
History display & Operation	Alarm & Operator message & Operation
Run hour / Parts count display	
Maintenance information	
Actual cutting feedrate display	
Display of spindle speed / T code	
Graphic display	
Operating monitor screen	Spindle / Servo load etc. Support 9 languages Chinese (Simplified/Traditional), English, French, German, Italian, Korean, Portuguese, Spanish [☆ 22 Support languages : Inquiry need]
Multi language display	
LCD Screen Saver	Screen saver & Motion sensing
Option	
Additional optional block skip	10 ea
Additional axis control	
Contour handwheel	
3D simulation	
Real time simulation	
ShopMill	Machining step programming for milling

Controller

MITSUBISHI M80

[] : Option ☆ Needed technical consultation

Number of control axis	Max. number of axis (NC axis + Spindles + PLC axis)	11
	Max. number of NC axis (in total for all the part systems)	8
	Max. number of spindles	2
	Max. number of PLC axis	6
	Max. number of PLC indexing axis	4
	Number of simultaneous contouring control axis	4
	Max. number of NC axis in a part system	8
Max. number of part systems (main + sub)	2	
Max. number of main part systems	2	
Max. number of sub part systems	-	
Control unit-side High-speed program server mode	-	
Display unit-side High-speed program server mode	Available	
Front-side SD card mode	Available	
Least command increment	0.1μm	
Least control increment	1nm	
Number of tool offset sets	400	
Max. program capacity	500kB (1,280m) (1,000)	
Max. PLC program capacity [steps]	64,000	
Multi-project [number of PLC projects stored]	3	
Interactive cycle insertion	-	
High-speed machining mode I maximum [kBPM]	33.7	
High-speed machining mode II maximum [kBPM]	67.5	
High-speed high-accuracy control I maximum [kBPM]	33.7	
High-speed high-accuracy control II maximum [kBPM]	67.5	
High-speed high-accuracy control III maximum [kBPM]	135	
High-accuracy control	Available	
SSS control (Super Smooth Surface)	Available	
Tolerance control	Available	
CC-Link (Master/Local)	Available	
PROFIBUS-DP (Master)	Available	
MES interface library	Available	
Smart Safety observation	Available	
Display unit	10.4 inch, touchscreen	
Windows@8 selection	-	

* Maximum specifications including optional specifications are listed. Refer to the Specifications List for the details of each option.