

# FM20

High-speed & Small 5-axis Machining Center

SG WIA 5-axis Machining Center

**FM20**, the world's top-tier 5-axis horizontal machining center, is the creation of the SGWIA Europe R&D Center. With an integrated bed & column structure, it not only provides outstanding structural stability, but also delivers unrivaled productivity with the world's top-level acceleration/deceleration 1.2G by giving the linear feed axis extraordinarily powerful feed capabilities

- Table Size : **Ø260 mm (Ø10.2")**
- Max. Load Capacity : **50 kg (110 lb)**
- Spindle Speed : **24,000 rpm**
- Spindle Output (Max./Cont.) : **12.5/8 kW (16.8/10.7 HP)**
- No. of Tools : **20 EA (Pick-UP) [40 EA (Chain)]**
- Travel (X/Y/Z) **300/300/200 mm (11.8"/11.8"/7.9")**
- Rapid Traverse Rate (X/Y/Z) **50/50/50 m/min (1,969/1,969/1,969 ipm)**



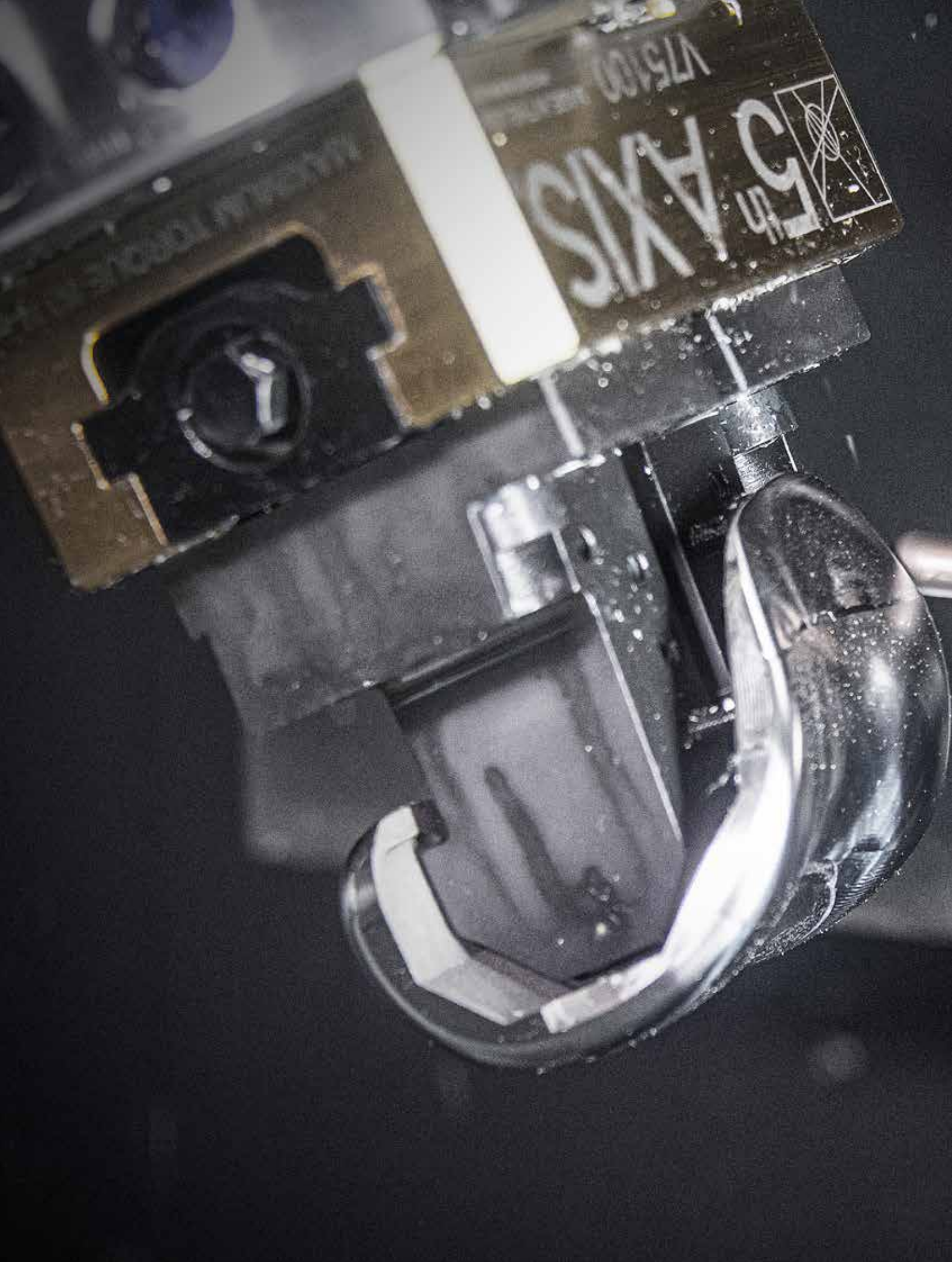

175100  
5th AXIS



# ULTRA PRECISION

The FM20 is an optimized solution for small composite composite processing with the highest speed and precision in its class. To offer the company's customers the highest level of productivity, it is equipped with an efficient structure, backed by a monoblock type bed and a cantilever type DDM table.

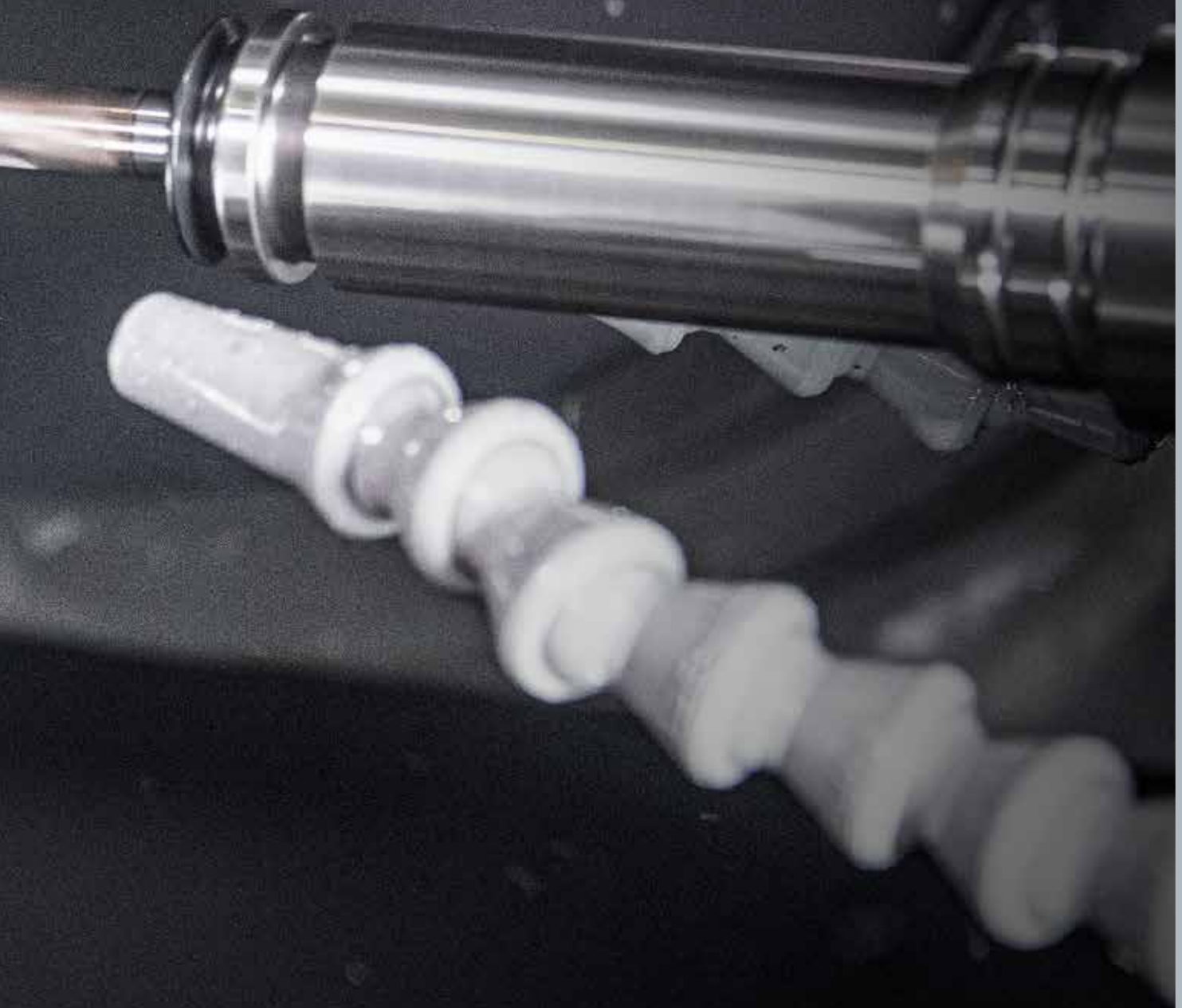

FM20  
5-AXIS MACHINING CENTER

04  
+  
05

CREATING VALUE  
IN SEAMLESS MOBILITY

# FM20

Cutting Edge Technology

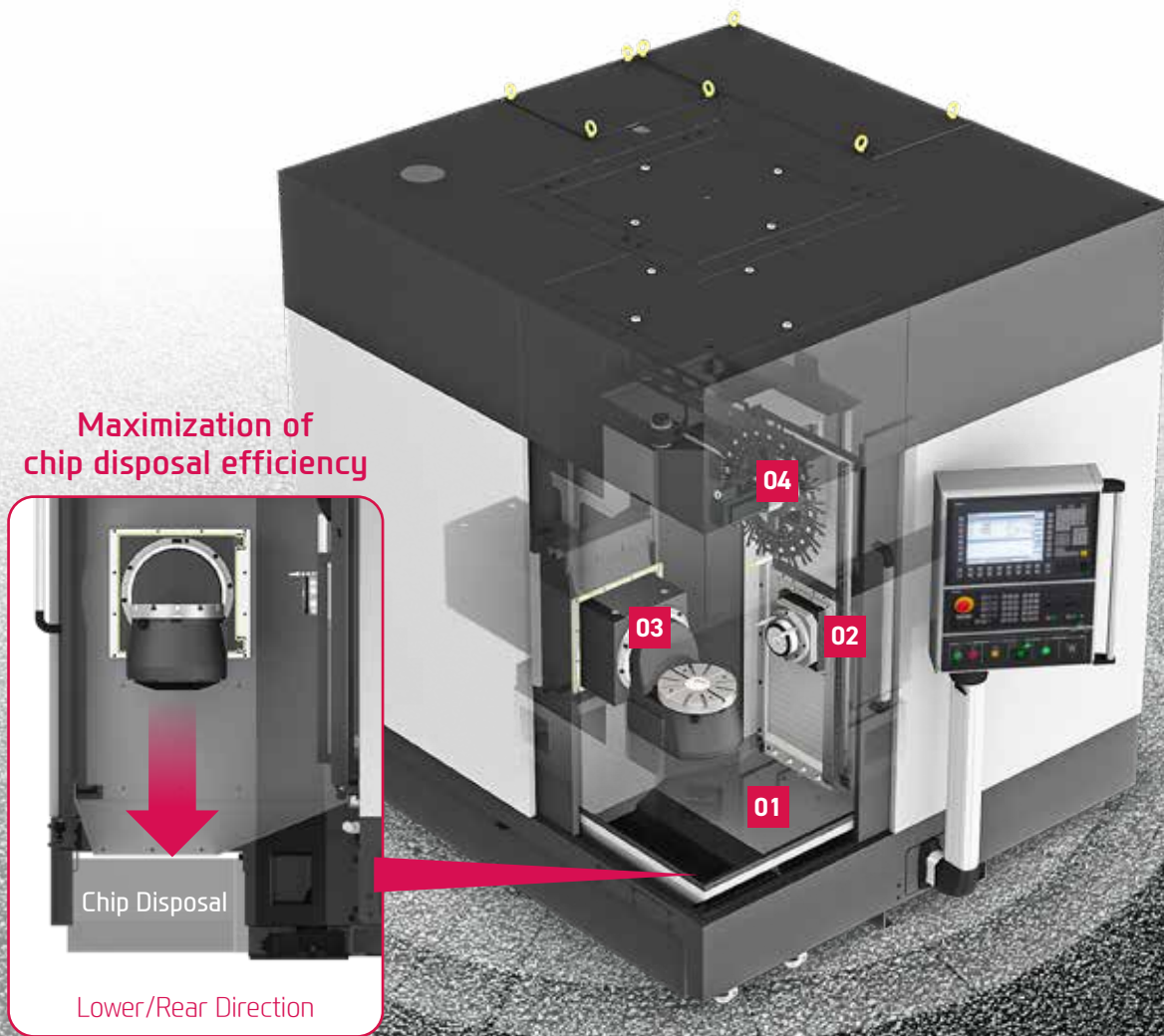

## High Precision & Speed 5-Axis Machining Center

50/50/50 m/min (1,969/1,969/1,969 ipm)  
Rapid Traverse Rate (X/Y/Z-axis)

120/120 r/min  
Rotation Speed (A/C-axis)

300/300/200 mm (11.8"/11.8"/7.9")  
Travel (X/Y/Z-axis)

240/360 deg  
Rotation Angle (A/C-axis)

# Basic Features

**01**

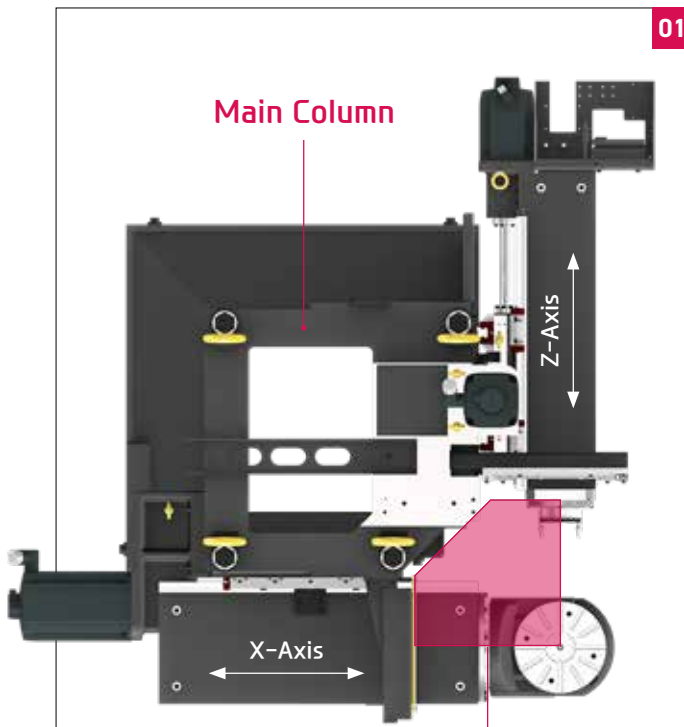

**Main Column**

**Z-Axis**

**X-Axis**

**Force Flow**

**One-piece Bed & Column**

The FM20 maximizes the dynamic rigidity by designing bed and column as an integral type, and improves the structural stability by concentrating the flow force between the work space and the tool.

**Linear Scale (Std.)**

Applied linear scale as a standard for high-precision machining through the compensation of thermal displacement.



**02**

**Built-In Spindle**

Designed with a built-in motor structure, the spindle provides maximum acceleration and deceleration while suppressing vibration and heat that can occur during the high-speed rotation. This leads to the excellent performance for high precision machining.



**03**

**DDM Tilting Rotary Table**

Precise 5-axis control can be done simultaneously by adopting DDM table, ensuring world-class travel speed to enhance productivity.



**04**

**Pickup-type Magazine**

Developed as a pickup-type magazine with a relatively simple structure, automatic tool loading device is unnecessary, which is excellent in maintenance.

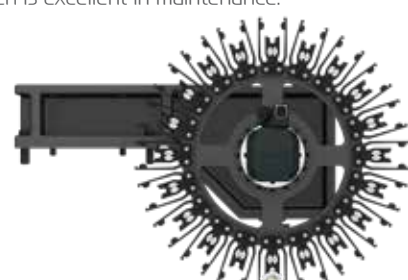

01  
FM20

# Basic Structure

High-Precision & Speed 5-Axis Machining Center

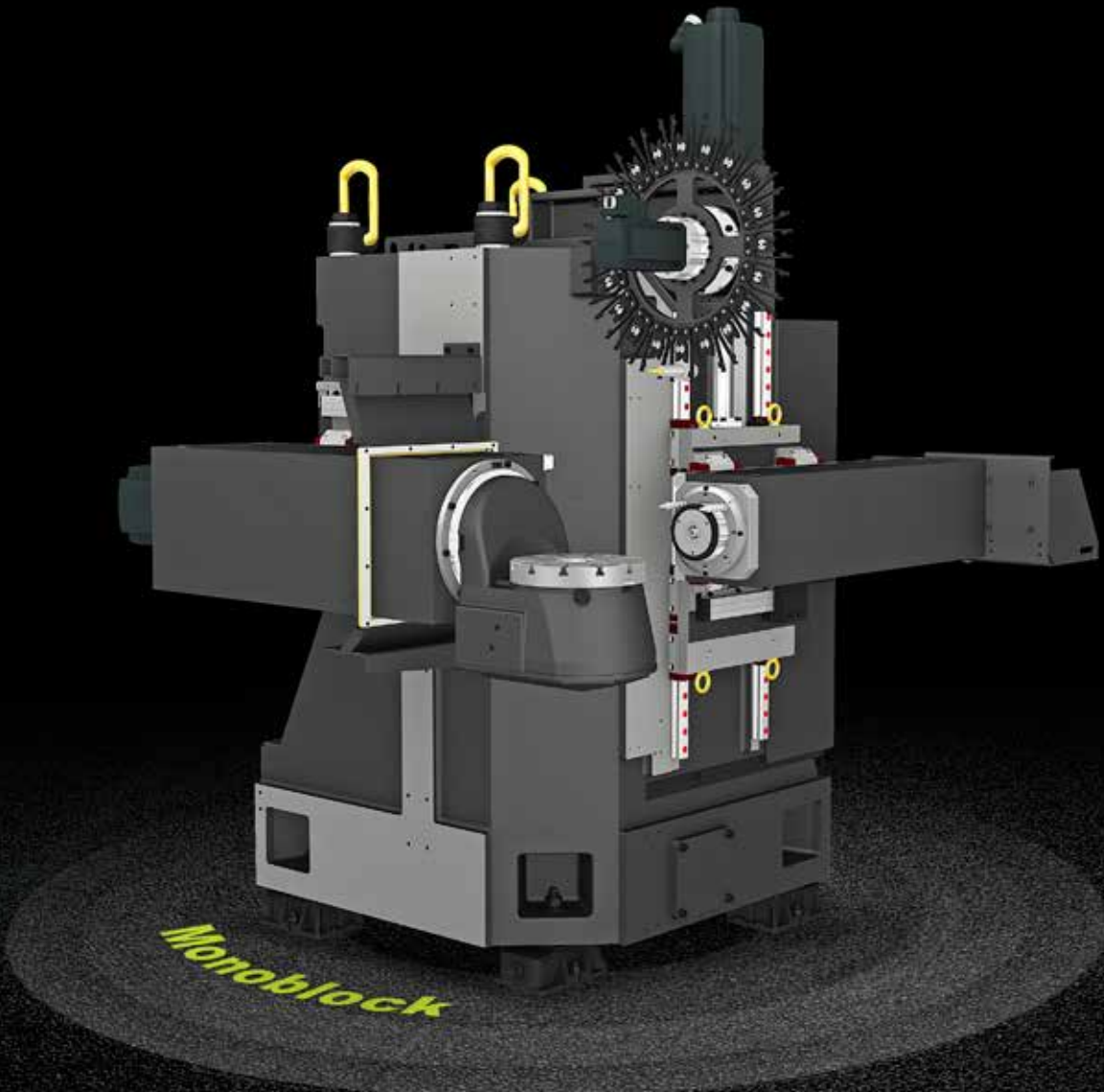

FM20, a compact size high-speed, high-precision 5-axis machine developed by SG WIA Europe R&D Center based in Germany, has optimized its structure to maximize its productivity. To complete the company's efforts toward a robust design, it applied a mechatronic simulation technique from initial design stage to maximize the mechanical performance of the machine tool.

The strength and rigidity of the base body structure are a direct link to the precision of a machine tool.

SG WIA's advanced body design coupled with an integrated bed/column structure is the foundation of machining perfection.

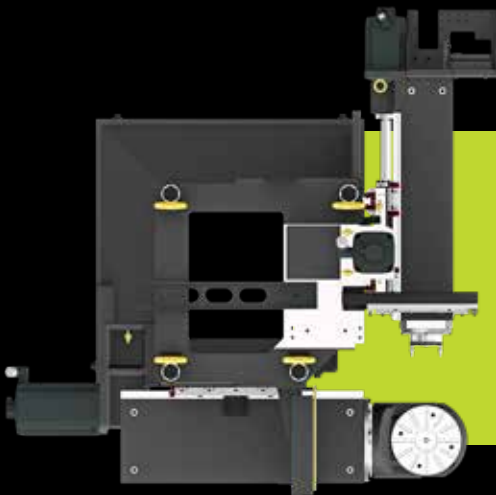

- > A monoblock type high rigidity, integrated bed & column
- > Ensuring a robust design through mechatronics simulations
- > An optimized casting rib structure for high rigidity
- > The maximization of operational efficiency by horizontally arranging the main spindle and the table
- > The bed structure designed to optimize operators' accessibility



### High-Speed Roller LM Guideway

Roller LM guide with high acc./deceleration and rigidity has applied to reduce non-cutting time.

◎ Acc./Deceleration Speed : 1.2G



### High-Precision Linear Scale (Standard)

The FM20 are equipped with linear scales on all axis providing high precision positioning accuracy and compensates for ball screw thermal displacement ensuring extremely precise machining.

In addition, the absolute type linear scale is installed in close proximity to the ball screw of each axis. During operation an added benefit is not being require to home the machine.



02  
FM20

## RAM Type Spindle

Long Lasting High Accuracy & Excellent Performance  
5-Axis Machining Center



# Spindle

## High-Precision Built-in Spindle

By using ultra precision angular ball bearings, fast acceleration and deceleration of the main spindle is achieved. The spindle head is designed to minimize the heat displacement of main spindle, and with the use of hydraulic tool lock system, the machining stability has increased.

### Spindle Cooling

Spindle temperature is controlled by the use of a spindle oil chiller. This ensures consistent spindle temperature which minimizes thermal displacement.

### HSK Tool Holder

HSK tool holder is utilized for precise positioning with less expansion in the spindle taper during high speed rotation. This ensures an excellent level of precision for die mold machining.



HSK-E40

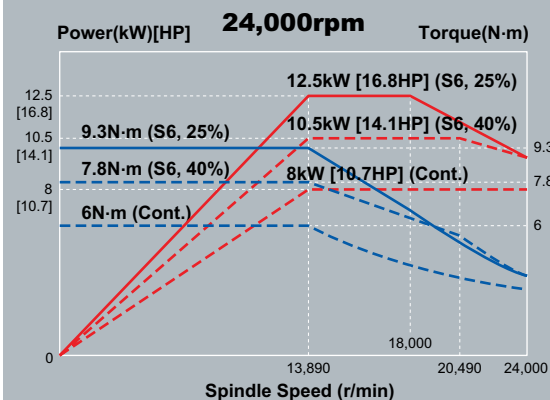

### Spindle Thru Coolant **OPTION**

Through Spindle Coolant is exceedingly useful when drilling deep holes. It helps increase the lifetime of the tool, while decreasing cycle time.

**20 bar / 30 bar / 70 bar**

24,000 rpm

**12.5/8**

kW (16.8/10.7 HP)  
Spindle Power (Max./Cont.)

**9.3/6**

N·m  
Spindle Torque (Max./Cont.)

03  
FM20

# Magazine & Table

Super Quality & Productivity  
5 Axis Machining Center



## ATC & Tool Magazine

Automatic tool loading device with unnecessary pick-up type magazine achieves best-in-class tool change time (chip to chip) of 4.5 seconds and excellent maintainability.

❖ 40 Tool Chain type Magazine Option

**20 [40]** ea  
No. of tools

**4.5 [5.0]** sec  
Tool change time (C-C)

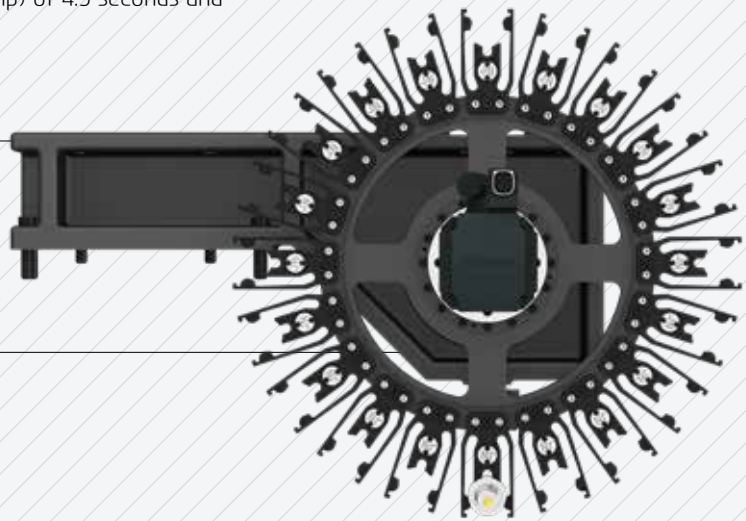

- ⦿ Max. Tool Dia. : **Ø50 (Ø2")**
- ⦿ Max. Tool Length : **150 mm (5.9")**
- ⦿ Max. Tool Weight : **1.5 kg (3.3 lb)**



## 5-axis DDM Table

Precise 5-axis control can be done simultaneously by adopting DDM table, ensuring world-class travel speed to enhance productivity.

- ⦿ Table Size : **Ø260 (Ø10.2")**
- ⦿ Load Capacity : **50 kg (110 lb)**
- ⦿ Tilting Angle (A axis) : **240° (+120°~-120°)**
- ⦿ Rotation Speed (A/C axis) : **120/120 rpm**

## A/C-axis Rotary Scale

High quality machining is achieved by scale built-in YRT bearing which is applied to the A/B-axis of rotary table.



LANG

5th AXIS

MAXIMUM TORQUE (N·M)



# FAST & DYNAMICS & CONVENIENCE

Highest level of acceleration and deceleration (FAST): Acc./Dec. time-1.2G

High performance built-in spindle (DYNAMIC)

High visibility programming and accessibility through its ergonomic design (CONVENIENCE)

Those are the values that the FM20 pursues.



FM20  
5-AXIS MACHINING CENTER

14  
+  
15

CREATING VALUE  
IN SEAMLESS MOBILITY

# 04

FM20

## SIEMENS Controller

The Powerful CNC Platform for Machine Tools



# SIEMENS

**DIFFERENTIATED CAPABILITIES,  
INTEGRATED ENGINEERING SEAMLESSLY INTERLINKED**

SIEMENS 840D sl is the latest generation CNC controller with the capability of running up to 20 axis on a single machine.

The powerful 80-bit controller reduces processing time and increases productivity. It supports the preparation of a variety of programs and setup functions for ease of operation.

# SIEMENS Controller



## SIEMENS Technology

### Shop Mill

- Dialogue-type programming, simple and convenient
- Effective specifications for small quantity batch production
- Step-by-step operation possible without knowledge of the DIN/ISO code



### Real Time 3D Simulation

- Real time 3D simulation is possible
- 2D simulation offered standard
- Possible to confirm NC program thru simulation



### Easy Screen

- Create an easy screen
- Insert text and pictures
- Max. 5-screen configuration
- NC variables and PLC interface with read/write support



## SIEMENS MDynamics



SIEMENS MDynamics is required for a variety of CNC mold processing software solutions which is combined into one package achieving the highest processing rates

### ISO Code Programming



If the ISO Dialect (G291) is ordered, JIS-based G-code programs can be used. (Standard)



# SPECIFICATIONS

## Standard & Optional

● : Standard ○ : Option ☆ : Prior Consultation - : Non Applicable

Spindle		FM20
24,000rpm	Built-in	●
Spindle cooling system	WATER Chiller	●
<b>ATC</b>		
ATC extension	20EA (Pick-UP Type)	●
	40EA (Chain Type)	○
Tool shank type	HSK E40	●
Tool weight	1.5kg (3.3 lb)	●
Servo motor drive magazine		●
<b>Table, APC &amp; Pallet</b>		
T-slot type pallet		●
Impeller type pallet		☆
<b>Coolant System</b>		
Std. coolant (Nozzle+Bed)		●
Shower coolant (Niagara)		○
Through spindle coolant (25 ℓ (6.6 gal))	20bar (290 psi)	○
	30bar (435 psi)	○
	70bar (1,015 psi)	○
Gun coolant		○
Air gun		○
Spindle air blow		○
Tool measuring air blow (Selected Tool measuring Device)		○
Coolant cooling device		○
Thru MQL device (without MQL)		☆
Air blow (for automation)		☆
Power coolant system (for automation)		☆
<b>Chip Disposal</b>		
Coolant tank	470 ℓ (124 gal) -High Level	●
Chip conveyor (Hinge/Scraper)	Rear	○
Chip wagon	Standard (180 ℓ [47.5 gal])	○
	Swing (200 ℓ [52.8 gal])	○
	Large Swing (290 ℓ [76.6 gal])	○
	Large Size (330 ℓ [87.2 gal])	○
Customized		☆
<b>Controller</b>		
SIEMENS 840Dsl		●
<b>S/W</b>		
Automatic CAM (HW-ACAM)		-
Dialogue Program (HW-DPRO)		○ (3+2 axis support)
DNC software (HW-eDNC)		○
Machine Monitoring System (HW-MMS Cloud)		☆
Machine Monitoring System (Customer Installation : HW-MMS Edge)		☆
Smart Guide-i : FANUC		-
Smart S/W		☆

ETC		FM20
Tool box		●
Customized color	Need for Munsel No.	☆
CAD & CAM software		☆
Total splash guard		●
<b>Electric Device</b>		
Call light & buzzer	3color : ● ■ ■ B	●
Work light		●
Electric cabinet light		○
Front door interlock		●
Side door interlock (Selected side auto door)		○
Remote MPG		●
3 axis MPG		○
Transformer (220V/380V)	40/10kVA	●
Spindle load meter	LED	○
Spindle speed meter	LED	○
Work counter	Digital	○
Total counter	Digital	○
Tool counter	Digital	○
Multi tool counter	6ea	○
	9ea	○
Auto power off		○
Splash memory card		○
Back up Module for Black out		○
AVR (Auto Voltage Regulator)		☆
<b>Measuring Device</b>		
Air Zero (Selected impeller table)	FESTO	●
	SMC	○
Work Measuring Device		○
TLM	Touch	☆
	Laser	○
Tool Broken Detective Device		○
Linear Scale	X/Y/Z Axis	●
Rotary Scale	A/C Axis	●
Coolant Level Sensor (Only for Chip Conveyor, Bladder Type)		☆
<b>Environment</b>		
Air Conditioner		●
Dehumidifier		○
Oil Mist Collector		○
Oil Skimmer (Only for Chip Conveyor)		○
MQL (Minimal Quantity Lubrication)		☆
<b>Fixture &amp; Automation</b>		
Auto door	Side	○
Sub operation pannel		☆
Control of Additional Axis	1 Axis	○
	2 Axis	○
External M code 4ea		○
Automation interface		○
I/O extension (In & out)	4 contact	○
	16 contact	○
<b>Hyd. Device</b>		
Std. hyd. unit	100bar (1,450 psi) / 4 ℓ (1 gal)	●
	45bar (653 psi)	☆
Hyd. unit for fixture	70bar (1,015 psi)	☆
	100bar (1,450 psi)	☆
	Customized	☆

# SPECIFICATIONS

## External Dimensions

unit : mm (in)

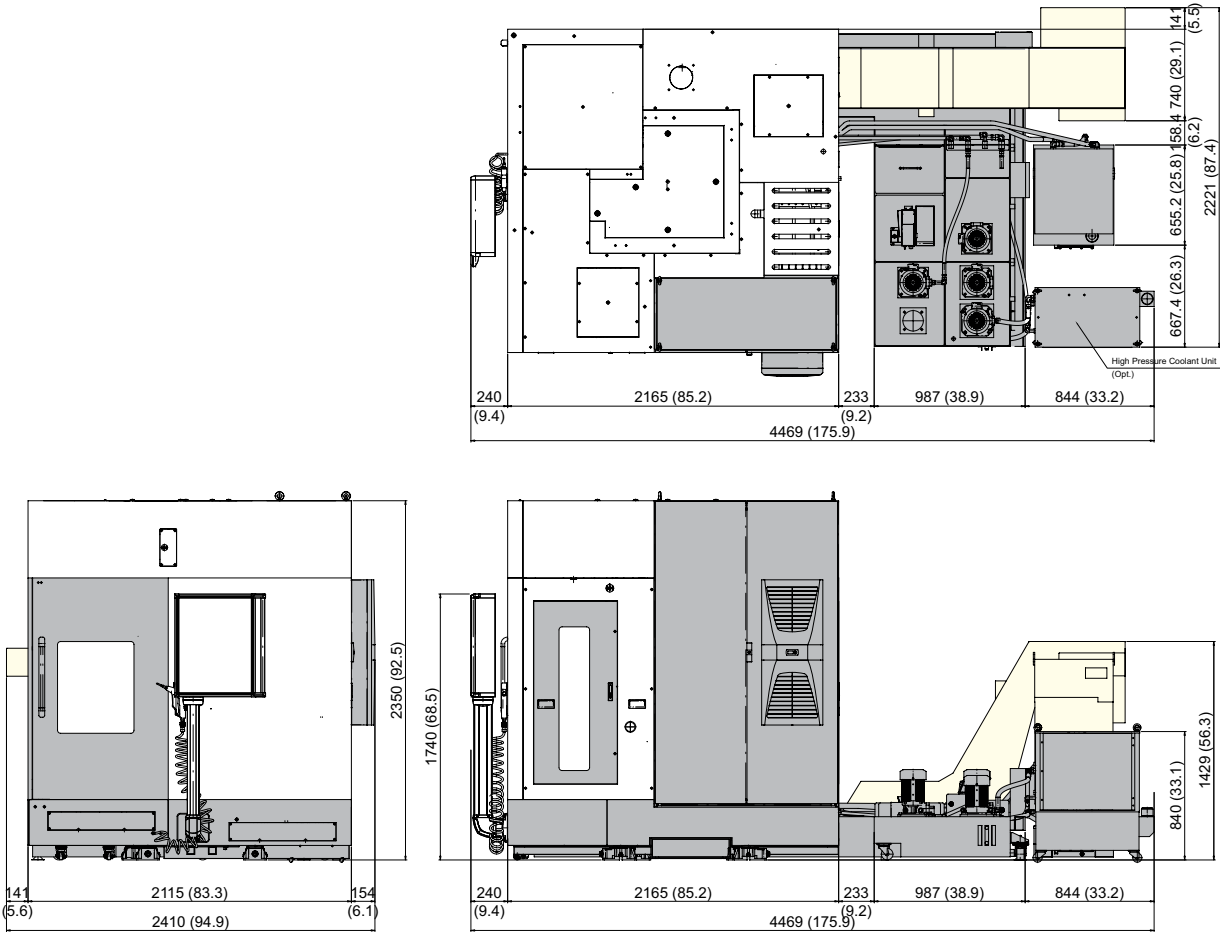

## Tool Shank

unit : mm (in)

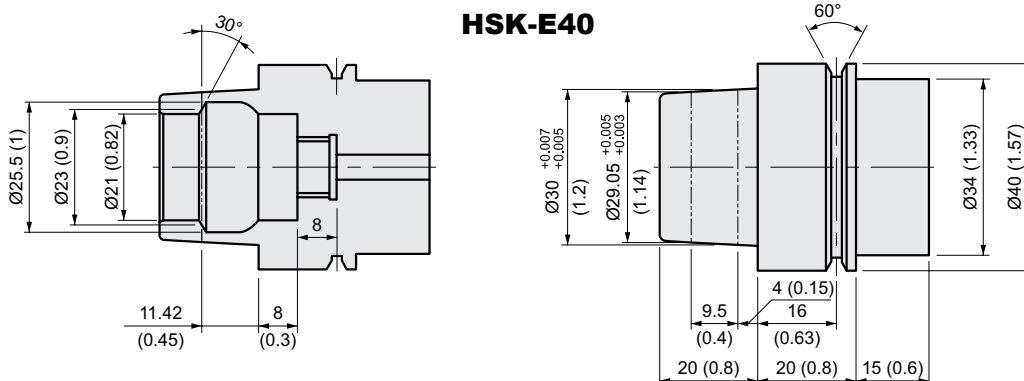

# SPECIFICATIONS

## Table Dimensions

unit : mm (in)

### Tilting : A-axis 0° (T-SLOT TABLE)

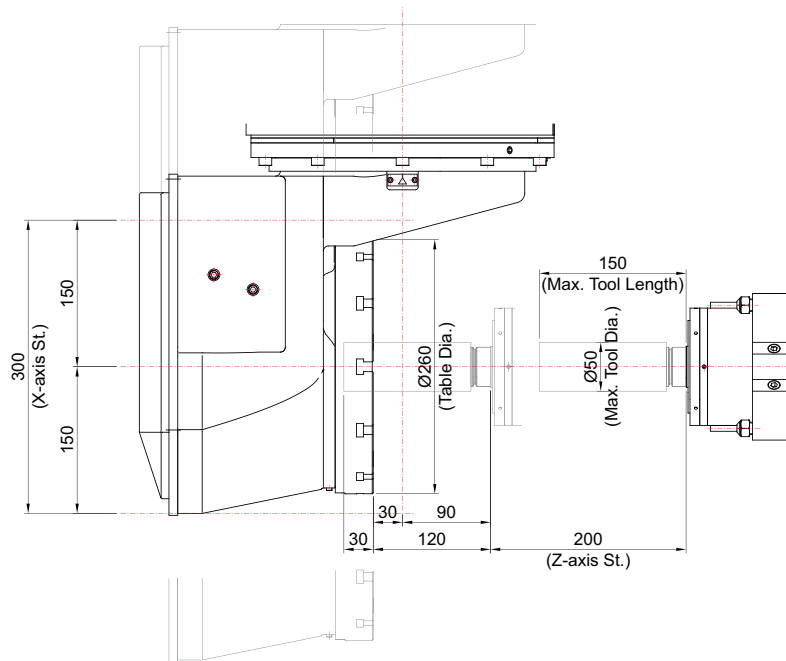

### (A-AXIS CENTER)

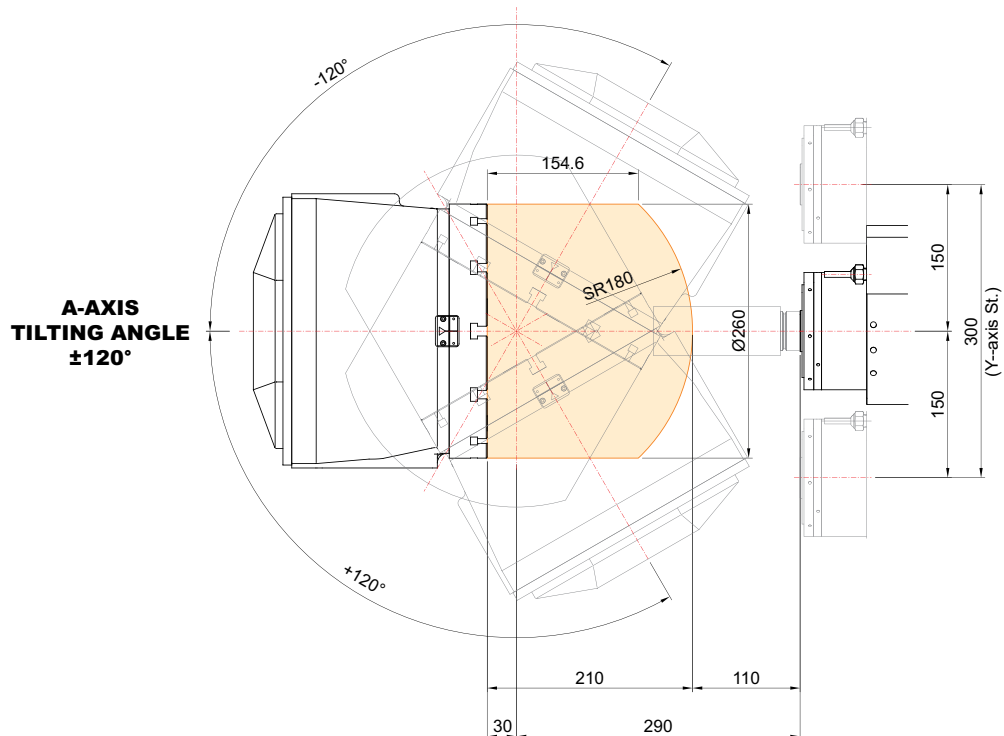

# SPECIFICATIONS

## Specifications

[ ] : Option

MODEL			FM20
TABLE	Table Size	mm(in)	Ø260 (Ø10.2")
	Maximum Load Capacity	kg(lb)	50 (110)
	Max. Macining Height	mm(in)	210 (8.3")
	Table Driving Method	mm(in)	DIRECT DRIVE MOTOR
SPINDLE	Spindle Taper	-	HSK-E40
	Spindle RPM	r/min	24,000
	Spindle Power Output (Max./Cont.)	kW(HP)	12.5/8 (16.8/10.7)
	Spindle Torque (Max./Cont.)	N·m	9.3/6
	Spindle Driving Method	-	BUILT-IN
FEED	Travel	X/Y/Z Axis mm(in)	300/300/200 (11.8"/11.8"/7.9")
	Rotation Angle	A/C Axis deg	240° (-120°~+120°)/360°
	Distance from Table Top to SP. Nose	mm(in)	-150 ~ 150 (-5.9 ~ 5.9)
	Rapid Traverse Rate	X/Y/Z Axis m/min(ipm)	50/50/50 (1,969/1,969/1,969)
	Rotation Speed	A/C Axis r/min	120/120
	Feed Axis Acc./Dec. Speed	G	All-axis 1.2
	Slide Type	-	ROLLER GUIDE
ATC	Number of Tools	ea	20 : Pick up Type [40 : Chain Type]
	Tool Shank	-	HSK-E40
	Max. Tool Dia. (W/T Adjacent Tool)	mm(in)	Ø50 (2")
	Max. Tool Length	mm(in)	150 (5.9")
	Max. Tool Weight	kg(lb)	1.5 (3.3)
	Tool Change Time	C-C sec	4.5 : Pick up Type [5.0 : Chain Type]
	Tool Selection Method	-	FIXED
TANK CAPACITY	Coolant Tank	ℓ (gal)	470 (124)
	Lubricating Tank	ℓ (gal)	2 (0.5)
	Hydraulic Tank	ℓ (gal)	3.9 (1)
POWER SUPPLY	Electric Power Supply	KVA	40
	Thickness of Power Cable	mm <sup>2</sup>	25 (AC 380V), 35 (AC 220V)
	Voltage	V/Hz	380,220/50,60
MACHINE	Floor Space (L×W)	mm(in)	2,410×4,469 (94.9"×175.9)
	Height	mm(in)	2,350 (92.5)
	Weight	kg(lb)	6,000 (13,228)
CNC	Controller	-	SIEMENS 840D sl

FM20  
5-AXIS MACHINING CENTER

20  
+  
21

CREATING VALUE  
IN SEAMLESS MOBILITY

# CONTROLLER

## SIEMENS 840D sl Standard

[ ] : Option ☆ Needed technical consultation

### Controlled axis / Display / Accuracy Compensation

Control axis	7 axis (X1, Y1, Z1, A1, C1, WR, AD)
Simultaneously controlled axis	Max. 5 axis
Least setting Unit	X, Y, Z axis : 0.001 mm (0.0001 inch), B, C, A axis : 0.001 deg
Least input increment	X, Y, Z axis : 0.001 mm (0.0001 inch), B, C, A axis : 0.001 deg
Inch / Metric changeover	G70 (inch) / G71 (metric)
Interlock	All axis / Each axis
Machine lock	All axis
Backlash compensation	
Pitch error compensation	
Feedforward control (Torque control)	
LCD / MDI	12 inch color LCD
Keyboard	ABCD Type
Stored stroke check	Over travel

### Operation

Automatic operation (Memory)	
MDI operation	
Program restart	
Program check function	Dry run / Program check / Machine lock
Single block	
Block search	Block search
Reposition	
Working area limit	Working area limitations

### Interpolation functions

Positioning	G00
Linear interpolation	G01
Circular interpolation	Circular interpolation CW (G02) Circular interpolation CCW (G03)
Exact position stop	Single block exact stop (G09) Exact stop G60 (G601, G602, G603)
Dwell	Dwell (G04)
Reference position return	Return to reference point Return to 2nd reference point
Helical interpolation	
Spline interpolation	Non-uniform rational B splines
Compressor (Improving machining quality)	Compcad / Compcurv (Cycle 832)

### Feed function / Acc. & Dec. control

Manual feed	Rapid traverse Jog Manual handle Reference position return
Cutting Feed command	Direct input F code
Feedrate override	0 ~ 120%
Rapid traverse override	1%, 25%, 50%, 100%
Feed per minute	G94
Feed per revolution	G95
Look-ahead block	3,000 block (With Mdynamics)

### Program input

ISO correspondence	G291(ISO)/G290 (SIEMENS) (ISO G Code system-A)
Optional block skip	8 ea (0~7)
Absolute / Incremental program	G90 / G91
Program stop / end	M00, M01 / M02, M30
Maximum command unit	± 999,999,999 mm, ± 99,999,9999 inch
Plane selection	X-Y : G17, X-Z : G18, Y-Z : G19 G54 ~ G57, G505~G549
Workpiece coordinate system	G500 (Basic frame - setable zero offset) G53 (Work offset non modal) G153 (basic frame non modal)
Sub program call	16 folds nested
G code preventing buffering	STOPRE
Drilling/Milling cycle	with programing support
User cycle	

### Auxiliary function / Spindle speed function

Auxiliary function	M Code 4 digit
Spindle speed function	S Code 5 digit
Spindle override	0% ~ 120%
Spindle orientation	SPOS
Rigid tapping	
Automatic mode Interchange	Spindle / Axis mode
Constant surface speed control	G96, G97
Spindle speed limitation	LIMS

### Tool function / Tool compensation

Tool function	Tool number & Tool name
Tool life management	
Tools in tool list	1,500 ea
Cutting Edges in tool list	3,000 ea
Tool radius compensation	ISO (G40, G41, G42)
Geometry / Wear compensation	
Measurement of tool length	
Tool management function	

### Editing function

Part program storage size	10MB
External Storage devices	USB
Background editing	
Extended part program editing	Copy, move and change of NC program
Memory card program edit	

### Data input / output & Interface

I/O interface	USB memory interface Embedded Ethernet memory interface
Screenshot	

### Setting, display and diagnosis

Self-diagnosis function	
History display & Operation	Alarm & Operator message & Operation
Run hour / Parts count display	
Regular maintenance screen	
Actual speed display	
Display of spindle speed / T code	
Graphic display	
Operating monitor screen	Spindle / Servo load etc.
Multi language display	Support 7 languages Chinese, English, French, German, Italian, Korean, Spanish
LCD Screen Saver	Screen saver & Motion sensing

### Function

ShopMill	Machining step programming for milling
3D simulation	
Real time simulation	

### Option

Built-in PC	Industrial PC (IPC427E)
Multi language display	☆ 20 Support languages : Inquiry need

Figures in inch are converted from metric values.

The SIEMENS controller specifications are subject to change based on the policy of company CNC supplying.