

HH40/50 SERIES

High Speed & Productivity Horizontal Machining Center

SGWIA Next Generation Machining Center



		HH40SMAX	HH50SMAX	HH505SMAX
Pallet Size (L×W)	mm(in)	2-400×400 (2-15.7"×15.7")	2-500×500 (2-19.7"×19.7")	
Maximum Load Capacity	kg(lb)	2-400 (2-881.8)	2-500 (2-1,102)	2-1,000 (2-2,205)
Spindle Taper	-	BBT40 [HSK-A63]		BBT50 [HSK-A100]
Spindle Speed	r/min	15,000 [15,000 High-Torque] [20,000]		10,000 [15,000]
Spindle Power (Max./Cont.)	kW(HP)	30/18.5 (40/25) [37/22 (50/30)] [37/18.5 (50/25)]		45/25 (60/33.5) [37/30 (50/40)]
Number of Tools	EA	Ring : 40 [60] [Chain : 90, 120] [Matrix : 240]		Ring : 40 [Chain : 60, 90, 120]
Travel (X/Y/Z)	mm(in)	560/640/660 (22"/25.2"/26")	730/730/880 (28.7"/28.7"/34.6")	800/800/880 (31.5"/31.5"/34.6")
Rapid Traverse Rate (X/Y/Z)	m/min	60/60/60		

[] : Option

Horizontal Machining Center with More Upgraded Quality & Performance

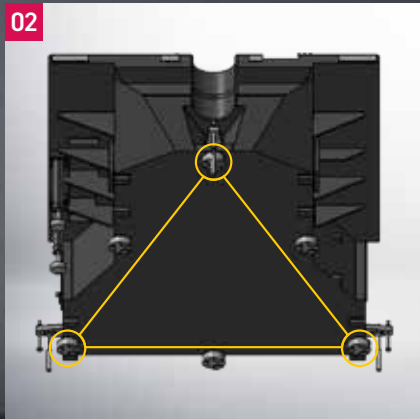

03 Built-in Spindle

01 High Speed Machining

04 Ring Type Magazine

02 High Rigidity Structure

05 High-performance APC

Highlight

The horizontal machining center is designed focus on achieving improvement in productivity compared to all other machine tools.

The HS-II Series offer high-speed feeding system, high-speed spindle, and high-speed ATC and APC for reduction of non-cutting time to guarantee global leading level of productivity.

Travel (X/Y/Z)

HH40SMAX

560/640/660 mm
(22"/25.2"/26")

HH50SMAX

730/730/880 mm
(28.7"/28.7"/34.6")

HH505SMAX

800/800/880 mm
(31.5"/31.5"/34.6")

Rapid Traverse Rate (X/Y/Z)

60/60/60 m/min

Acc./Deceleration Speed (X/Y/Z)

1.0/1.1/1.1 G
(HH40SMAX Standard)



60/60/60 min

Highlight

01 _ High Speed Machining



Roller LM Guideway

High-performance roller-type LM guide was applied to fulfill high-speed and rigidity.



Ball Screw Shaft Cooling

Shaft cooling type ball screw as a standard in order to minimize thermal displacement from repetitive motion of ball screw.



Large diameter ball screw of $\varnothing 50\text{mm}$ offers improvement in rigidity and lifespan.

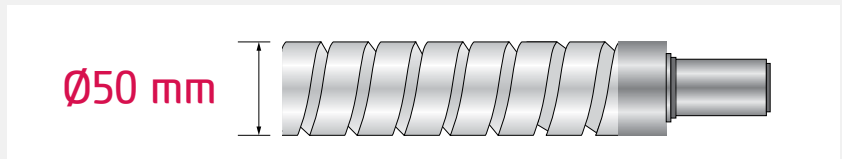

Grease Lubrication Device

Automatic grease lubrication eliminates the need for an oil skimmer and significantly reduces maintenance costs against oil lubrication.

Highlight

02 _ High Rigidity Structure

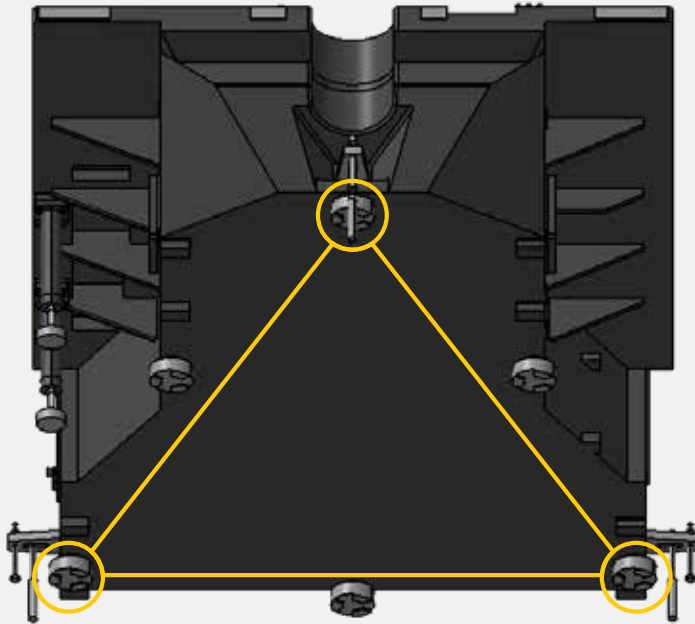

3-point Support Bed Structure

The HS-II Series is the first series of the company to apply the three-point support bed which is a criteria for high-rigidity structure.

The three-point support bed is a structure that allows easy machining as long as the three levels at the bottom of the bed are stabilized during initial setup, and such machining is only available with support from structural rigidity of the machine. Initial construction is especially not necessary during initial setup and this can minimize the equipment setup time which makes it very efficient for use of equipment.

Step Type Bed Structure

Step-type bed was applied to sufficiently withstand the thrust generated from Z-axis machining. Furthermore, stability was improved even more with the low center of gravity design of the feeding related unit.

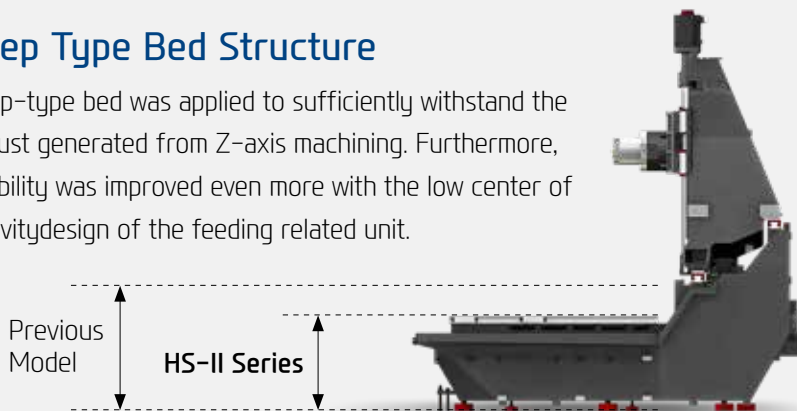



Max. 20,000 rpm (Opt.)

Highlight

03 _ Built-in Spindle



High-performance Built-in Spindle

The HS-II Series has applied a standard built-in spindle of 15,000 rpm to respond to high-speed machining. The built-in spindle capable of 15,000 rpm consists of standard specifications of 30kW (40HP)/230N·m (169.6 lbf·m) and 37kW (50HP)/303N·m (223.5 lbf·m) for customers to be able to select the spindle based on their machining conditions.

(HH505SMAX : 10,000 [Opt. : 15,000] rpm)

Chip Stack Prevention Coolant on the Upper Part of the Spindle

Chip stack prevention coolant is applied as a standard on the upper part of the spindle to create a pleasant working environment.

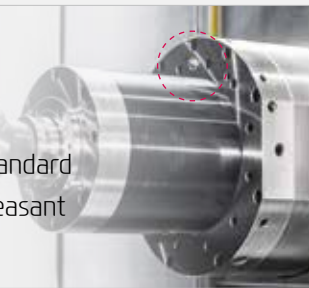

HH505MAX Cutting Possibility

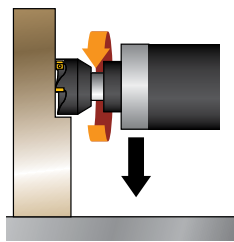

FACE MILL (Material : S45C (Carbon steel))

Tool dia.	Ø125 mm
Cutting quantity	788 cm ³ /min
Spindle speed	1,200 r/min
Rapid feed rate	2,160 mm/min

Highlight

04 _ Ring Type Magazine

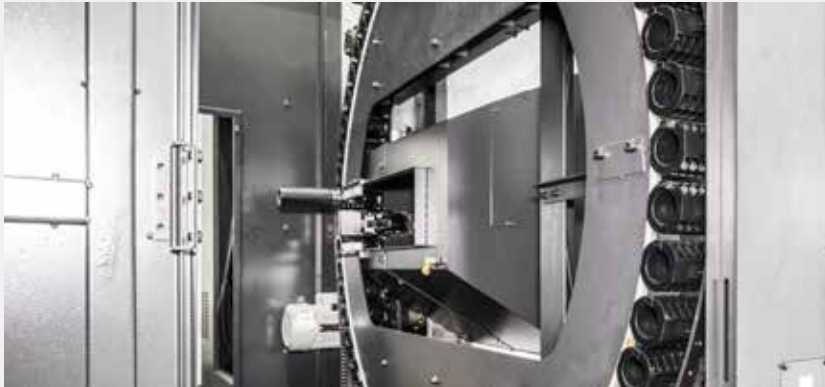

Ring Typ	Chain Type	Matrix Type
40 EA [60 EA]	[90, 120 EA]	[240 EA]

HH505SMAX : Ring Type : 40 EA [Chain Type : 60, 90, 120 EA] [] : Option

Ring Type Magazine

The HS-II series has a ring type magazine as standard.

The ring type magazine makes less noise than the existing chain type and has faster rotation of the magazine, which contributes to reduced tool exchange time and improved productivity.

Magazine Max Call Time (40T)

Previous Machine	C-C	3.7 sec
HH40SMAX	C-C	2.3 sec 30% reduction

Front Placement of the Magazine for Worker Convenience

Magazine installed at the side was installed at a location which is closest possible to the front door to improve material and tool exchange convenience.

Servo ATC

Servo motor is applied on the ATC to reduce tool change time.

Previous Machine	C-C	2.6 sec
HH40SMAX	C-C	2.3 sec 11% reduction

Ring Type / C-C : 2.3 sec



Highlight

SGWIA
MACHINE TOOL

HH40/50 Series
Horizontal Machining Center

08
+
09

CREATING VALUE
IN SEAMLESS MOBILITY

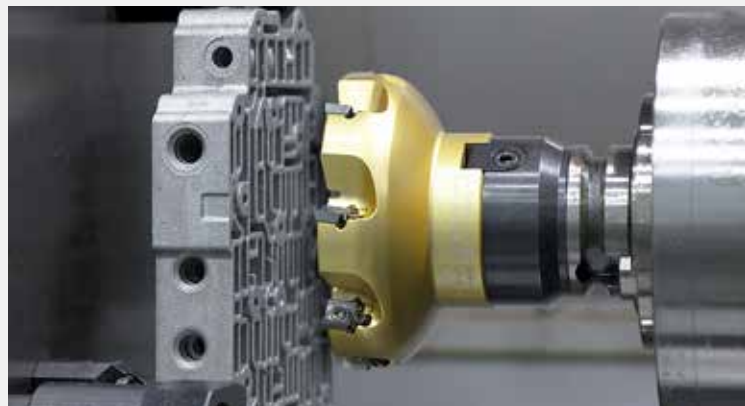

Applicability of Large Tools

The HS-II Series can apply larger tools compared to the previous model which improves machining capability.

Previous Machine Max. Tool Dia. $\varnothing 75/\varnothing 140$

HH40SMAX Max. Tool Dia. $\varnothing 75/\varnothing 170$ $\varnothing 30 \uparrow$

Previous Machine Max. Tool Weight 8 kg

HH40SMAX Max. Tool Weight 12 kg 4 kg \uparrow

Previous Machine Max. Tool Length 350 mm

HH40SMAX Max. Tool Length 450 mm 100 mm \uparrow

Highlight

05 _ High-performance APC



High Speed & Rigidity APC

The HS-II Series contributes to improvement in productivity by reducing the APC exchange time and increasing rigidity compared to the previous model.

Previous Machine	Pallet Changing Time	10 sec
HH40SMAX	Pallet Changing	8 sec 2 sec reduction
Previous Machine	Pallet Changing Time	12 sec
HH50SMAX	Pallet Changing Time	9.2 sec 1.8 sec reduction

Roller Gear Cam Type 0.001° Pallet **OPTION**

The pallet rotation for the previous model of the company and other equipment from different manufacturers operated by the worm gear method but the 0.001° pallet which comes as an option for HS-II Series operates by the roller gear cam method. The roller gear cam method features less power loss from smooth movement along the cam curve, and it is more advantageous for high-speed rotation due to generating less friction from rotation of the roller rather than the gear.

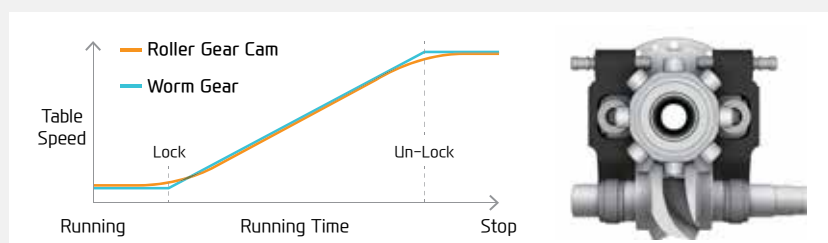

APC Change Time : 8 sec

Highlight

SGWIA
MACHINE TOOL

HH40/50 Series
Horizontal Machining Center

CREATING VALUE
IN SEAMLESS MOBILITY

10
+
11

Maximum Workpiece Size

The HS-II Series expanded the maximum size of workpiece compared to the previous model for large workpiece machining.

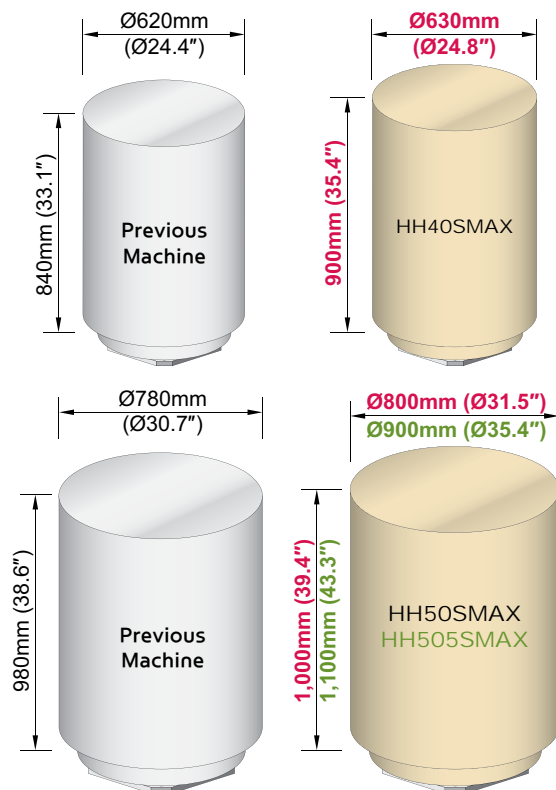

Chip Disposal

Chip Disposal



Direct Chip Discharge Structure

The structure was designed for the chip to fall directly to the center of the bed to improve chip discharge capability, and the lack of necessity for a separate internal screw conveyor fundamentally eliminated the chip trouble from the internal screw conveyor.



Chip Conveyor

Hinge	Chip Type : Roughing Chip, Long Chip, Chip complex
	Highly efficient when disposing a lot of chips. Capable of handling stringy chips.
Scraper	Chip Type : Finely broken chip blown out
	Convenient for shortly cut chips.
❖ Drum Filter	Chip Type : Powder, Micro Chip
	Advantageous in precision, as the chips do not flow in to the coolant nozzle.

Timely and effective disposal of chips will improve productivity as well as working environment.



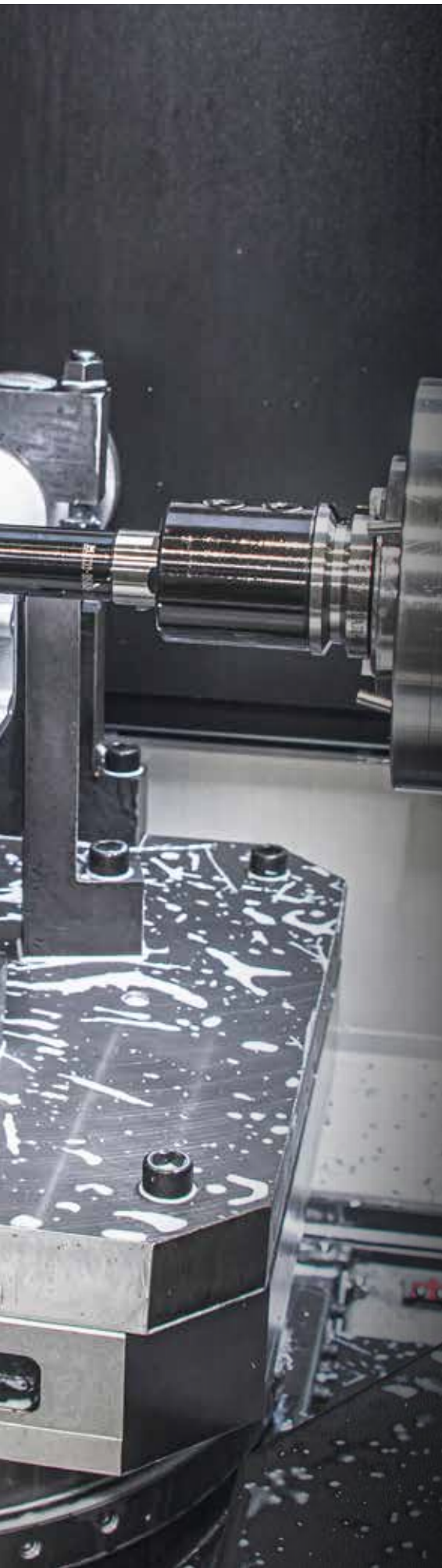

Coolant

Coolant Unit



Std. Coolant (Nozzle)



Shower Coolant (Opt.)



Gun Coolant (Opt.)



Air Gun (Opt.)

APC (Work Setting)

The height to the top of the pallet was designed to be lower compared to the previous model to improve convenience for work setting.

Height from the ground surface to the top of the pallet

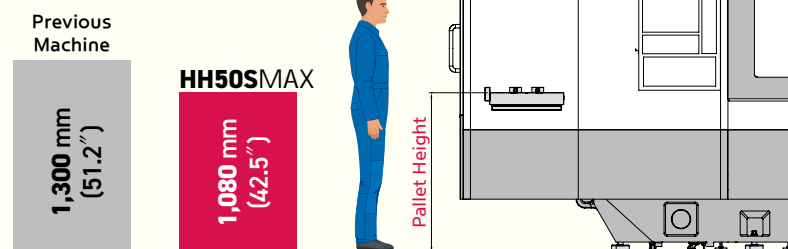

Convenience

PLS



PLS (Pallet Line System)

SGWIA Pallet Line System is High level of automation system with multi-level pallet rack

SGWIA PLS is an unmanned automation system for horizontal machining centers with two-storied pallet stackers to achieve a reasonable installation area.

Especially, it contributes to productivity improvement by easy and efficient system operation to flexibly respond to changes in production volume.

ITEM		HH40SMAX	HH50SMAX	HH505SMAX
Pallet Size (L×W)	mm (in)	400×400 (15.7"×15.7")	500×500 (19.7"×19.7")	
Max. Load Capacity	kg (lb)	400 (882)	500 (1,102)	800 (1763.7)
Max. Machining Dia.	mm (in)	Ø630 (24.8")	Ø800 (31.5")	Ø900 (35.4")
Max. Machining Height	mm (in)	900 (35.4")	1,000 (39.4")	1,100 (43.3")
No. of Pallet	EA	12~72		
No. of Loading Station	EA	1~4		
No. of Machine Tools	EA	1~7		

MPS



MPS (Multi Pallet System)

- Increased Operation Time & Utilization Rate
- Reduced Initial Investment Costs Compared to Single Machine
- PALLEX Operating S/W
- Compact installation area compared to other companies (4,375×3,266 mm)

ITEM		MPS500
Pallet Size (L×W)	mm (in)	500×500 (19.7"×19.7")
Max. Load Capacity	kg (lb)	700 (1,543) - Pallet included
Max. Machining Dia.	mm (in)	Ø800 (Ø31.5")
Max. Machining Height	mm (in)	700 (27.6")
No. of Pallet	EA	21 (7×3 Level)
Rotation Speed	min ⁻¹	9
Lifting/Poking Speed	m/min	15/15

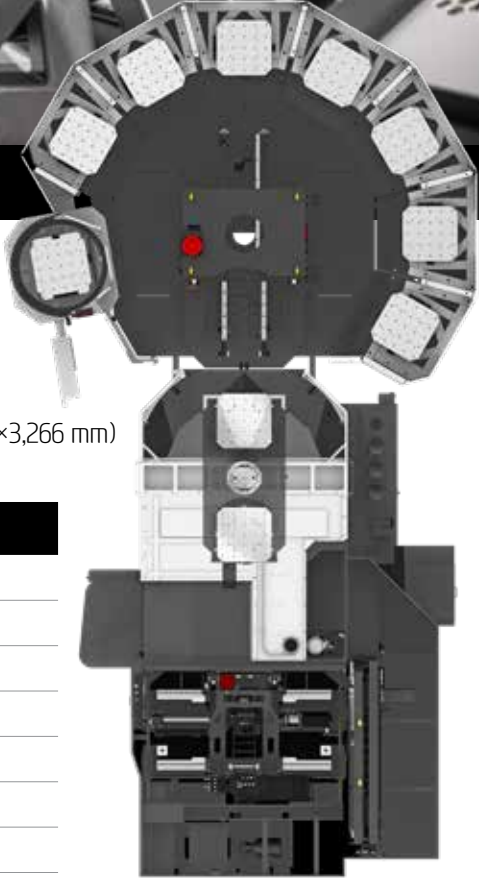

FANUC – Smart Plus

FANUC 31i-B Plus

This is the core model of FANUC CNC with the performance of the world highest level. With abundant functions and high-speed, highly-accurate and high-quality machining technology, it is the most suitable for a high-grade and machining center.



15" Touch Screen Monitor Applied

Control axis : 4 axis (X, Y, Z, B)

Simultaneously controlled axis :
3 axis [Max. 4 axis]

Part program storage size : 4 Mbyte (10240m)

No. of registerable programs : 1,000 EA

Tool offset pairs : 400 pairs

Look-ahead block : 1,000 block

Conversational auto program : Smart Guide i

The HS-II Series has a 15" large monitor for enhanced visibility.

In particular, we can create more convenient use conditions by improving the operating environment such as program setup and simulation through a large screen.



Convenience is increased when inputting and outputting program. The USB port is available in addition to the former input output methods such as CF memort card and LAN.

MMS (Machine Monitoring System)



Manufacturing big data solution with design, manufacturing, and intelligence technology of SG-WIA (Big data collection/Analysis/Visualization)



1. MMS Cloud

A cloud server-based machine monitoring system for collecting and analyzing facility operation data.

2. MMS Edge

A client server-based tool monitoring system for collection/analysis of facility operation data. (Compatible with client MES / ERP interface)

SMART CNC (FANUC Smart Plus)



1. Dialogue Program (Smart Guide-i)

This software offers the maximum user convenience through dialogue manipulation from setup to processing. This includes writing processing programs and simulation checks.

2. LAUNCHER

This software offers shortcuts for quick access to specialized features and frequently used features.

Specifications

Standard & Optional

Spindle		HH40SMAX	HH50SMAX
15,000rpm (30kW)		●	●
15,000rpm (37kW) - High Torque		○	○
20,000rpm (37kW)		○	○
Spindle Cooling System		●	●
ATC			
ATC Extension	40 (Ring)	●	●
	60 (Ring)	○	○
	90/120 (Chain)	○	○
	240 (Matrix)	☆	☆
Tool Shank Type	BBT40	●	●
	HSK-A63	○	○
	BCV40	○	○
Tool Weight	12KG	●	●
Table, APC & Pallet			
APC	Rotary Turn	●	●
Tap Type Pallet		●	●
T-Slot Pallet		○	○
B Axis Table	1°	●	●
	0.001°	○	○
Coolant System			
Std. Coolant (Nozzle)		●	●
*Through Spindle Coolant	20bar	○	○
	30bar	○	○
	70bar	○	○
Bed Flushing Coolant		●	●
Shower Coolant		○	○
Gun Coolant		○	○
Air Gun		○	○
Cutting Air Blow		○	○
Tool Measuring Air Blow (Only for TLM)		○	○
Air Blow for Automation		☆	☆
Thru MQL Device (Without MQL)		☆	☆
Coolant chiller (Sub tank)		☆	☆
Power Coolant System (For Automation)		☆	☆
Chip Disposal			
Coolant Tank	600 ℓ	●	●
Chip Conveyor (Hinge/Scraper)	Rear (Right)	○	○
	Rear (Rear)	○	○
Special Chip Conveyor (Drum Filter)		☆	☆
Chip Wagon	Standard (180 ℓ)	○	○
	Swing (200 ℓ)	○	○
	Large Swing (290 ℓ)	○	○
	Large Size (330 ℓ)	○	○
	Customized	☆	☆
S/W			
Dialogue Program (HW-DPRO)		○	○
DNC software (HW-eDNC)		○	○
Machine Monitoring System (HW-MMS Cloud)		☆	☆
Machine Monitoring System (Customer Installation : HW-MMS Edge)		☆	☆
Smart Guide-i : FANUC		●	●
Smart S/W		☆	☆

● : Standard ○ : Option ☆ : Prior Consultation - : Non Applicable

Electric Device		HH40SMAX	HH50SMAX
Call Light	1 Color : ●	●	●
Call Light & Buzzer	3 Color : ● ● ● B	○	○
Work Light (LED)		●	●
Electric Cabinet Light		○	○
Remote MPG		●	●
3 Axis MPG		○	○
Work Counter	Digital	○	○
Total Counter	Digital	○	○
Tool Counter	Digital	○	○
Multi Tool Counter	6EA/9EA	☆	☆
Electric Circuit Breaker		○	○
AVR (Auto Voltage Regulator)		☆	☆
Transformer	60kVA	○	○
Auto Power Off		○	○
Back up Module for Black out		○	○
Measuring Device			
Air Zero	TACO	○	○
	SMC	○	○
Work Measuring Device		☆	☆
TLM	Touch/Laser	○	○
Tool Broken Detective Device		☆	☆
Linear Scale	X/Y/Z Axis	○	○
Environment			
Air Conditioner		○	○
Dehumidifier		○	○
Oil Mist Collector		☆	☆
MQL (Minimal Quantity Lubrication)		☆	☆
Fixture & Automation			
Auto Door		○	○
Sub O/P		☆	☆
External M Code 4ea		○	○
Automation Interface		☆	☆
I/O Extension (In & Out)	16/32 Contact	☆	☆
6PPL / PLS		☆	☆
Hyd. Device			
Std. Hyd. Unit	65bar/45 ℓ	●	●
Center Type Hyd. Supply Unit (Upper)	2×3 (6P)	☆	☆
	2×4 (8P)	☆	☆
	2×6 (12P)	☆	☆
	2×8 (16P)	☆	☆
Center Type Hyd. Supply Unit (Lower)	2×6 (12P)-0.001°	-	-
Hyd. Unit for Fixture	45bar	☆	☆
	70bar	☆	☆
	100bar	☆	☆
	Customized	☆	☆
ETC			
Tool Box		●	●
Customized Color	Need for Munsel No.	☆	☆
CAD&CAM Software		☆	☆

* Through Spindle Coolant* : Please check the filter types with sales representative.

Specifications are subject to change without notice for improvement. / Please refer to the S/W catalog (iRIS) for details by S/W product.

Specifications

Standard & Optional

● : Standard ○ : Option ☆ : Prior Consultation - : Non Applicable

Spindle		HH505SMAX
10,000rpm (45kW)		●
15,000rpm (37kW)		○
Spindle Cooling System		○
ATC		
ATC Extension	40 (Ring)	●
	60/90/120 (Chain)	○
	240 (Matrix)	☆
Tool Shank Type	BBT50	●
	HSK-A100	○
	BCV50	○
Tool Weight		25KG ●
Table, APC & Pallet		
APC	Rotary Turn	●
Tap Type Pallet		●
T-Slot Pallet		○
B Axis Table	1°	●
	0.001°	○
Coolant System		
Std. Coolant (Nozzle)		●
*Through Spindle Coolant	20bar	○
	30bar	○
	70bar	○
Bed Flushing Coolant		●
Shower Coolant		○
Gun Coolant		○
Side Oil Hole Coolant		☆
Air Gun		○
Cutting Air Blow		☆
Tool Measuring Air Blow (Only for TLM)		○
Air Blow for Automation		☆
Thru MQL Device (Without MQL)		☆
Coolant chiller (Sub tank)		☆
Power Coolant System (For Automation)		☆
Chip Disposal		
Coolant Tank		600 ℓ ●
Chip Conveyor (Hinge/Scraper)	Rear (Right)	○
	Rear (Rear)	○
Special Chip Conveyor (Drum Filter)		☆
Chip Wagon	Standard (180 ℓ)	○
	Swing (200 ℓ)	○
	Large Swing (290 ℓ)	○
	Large Size (330 ℓ)	○
	Customized	☆
S/W		
Dialogue Program (HW-DPRO)		○
DNC software (HW-eDNC)		○
Machine Monitoring System (HW-MMS Cloud)		☆
Machine Monitoring System (Customer Installation : HW-MMS Edge)		☆
Smart Guide-i : FANUC		●
Smart S/W		☆

Electric Device		HH505SMAX
Call Light	1 Color : ●	●
Call Light & Buzzer	3 Color : ● ■ ■ B	○
Work Light (LED)		●
Electric Cabinet Light		○
Remote MPG		●
3 Axis MPG		○
Work Counter	Digital	○
Total Counter	Digital	○
Tool Counter	Digital	○
Multi Tool Counter	6EA/9EA	☆
Electric Circuit Breaker		○
AVR (Auto Voltage Regulator)		☆
Transformer	65kVA	○
Auto Power Off		○
Back up Module for Black out		○
Measuring Device		
Air Zero	TACO	○
	SMC	○
Work Measuring Device		☆
TLM	Touch/Laser	○
Tool Broken Detective Device		☆
Linear Scale	X/Y/Z Axis	○
Environment		
Air Conditioner		○
Dehumidifier		○
Oil Mist Collector		☆
MQL (Minimal Quantity Lubrication)		☆
Fixture & Automation		
Auto Door		○
Sub O/P		☆
External M Code 4ea		○
Automation Interface		☆
I/O Extension (In & Out)	16/32 Contact	☆
6PPL / PLS		☆
Hyd. Device		
Std. Hyd. Unit	65bar/45 ℓ	●
Center Type Hyd. Supply Unit (Upper)	2×3 (6P)	☆
	2×4 (8P)	☆
	2×6 (12P)	☆
Center Type Hyd. Supply Unit (Lower)	2×8 (16P)	☆
	2×6 (12P)-0.001°	-
Hyd. Unit for Fixture	45bar	☆
	70bar	☆
	100bar	☆
	Customized	☆
ETC		
Tool Box		●
Customized Color	Need for Munsel No.	☆
CAD&CAM Software		☆

* Through Spindle Coolant* : Please check the filter types with sales representative.

Specifications are subject to change without notice for improvement. / Please refer to the S/W catalog (iRS) for details by S/W product.

Specifications

Spindle Output/Torque Diagram

HH40SMAX | HH50SMAX
15,000rpm

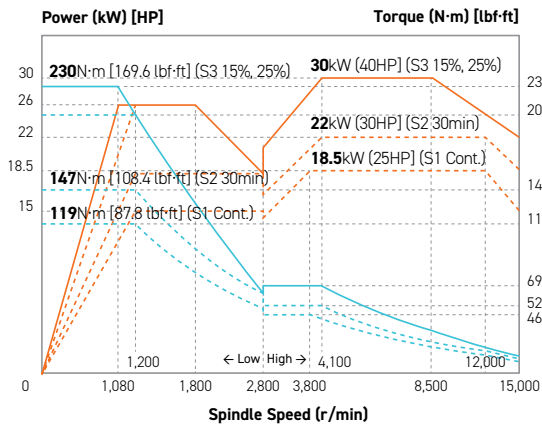

HH40SMAX | HH50SMAX
15,000rpm (High-Torque)

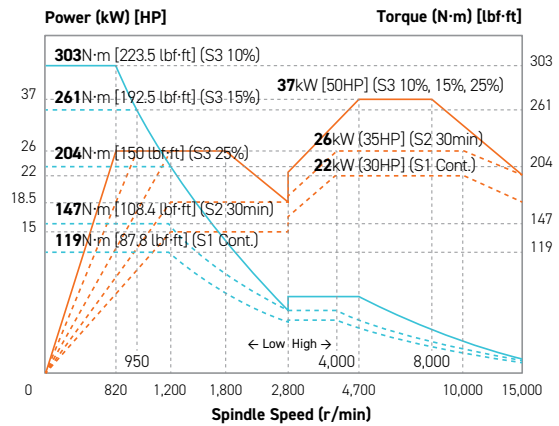

HH40SMAX | HH50SMAX
20,000rpm

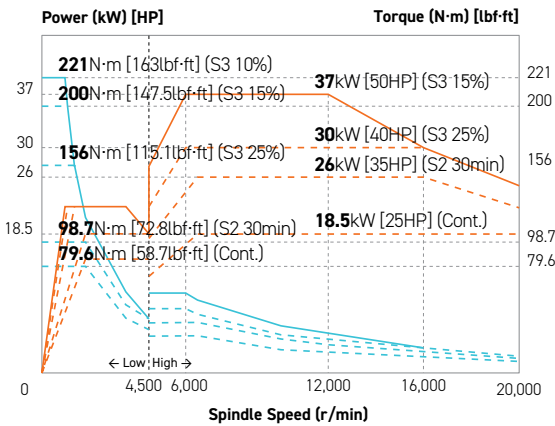

HH505SMAX
10,000rpm

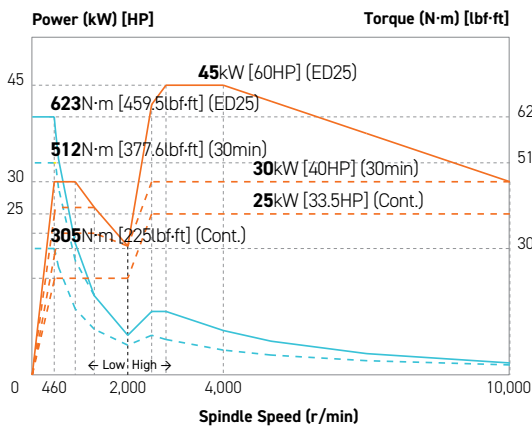

HH505SMAX
15,000rpm

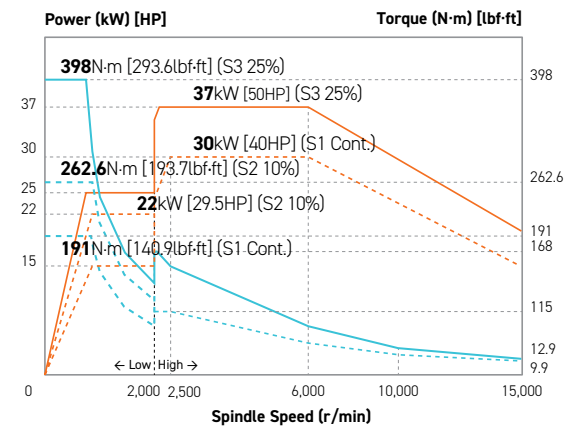

Specifications

External Dimensions

unit : mm(in)

HH40SMAX

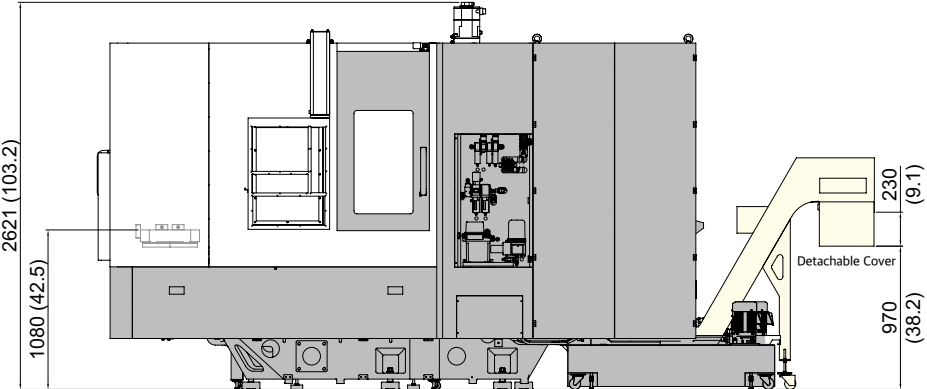
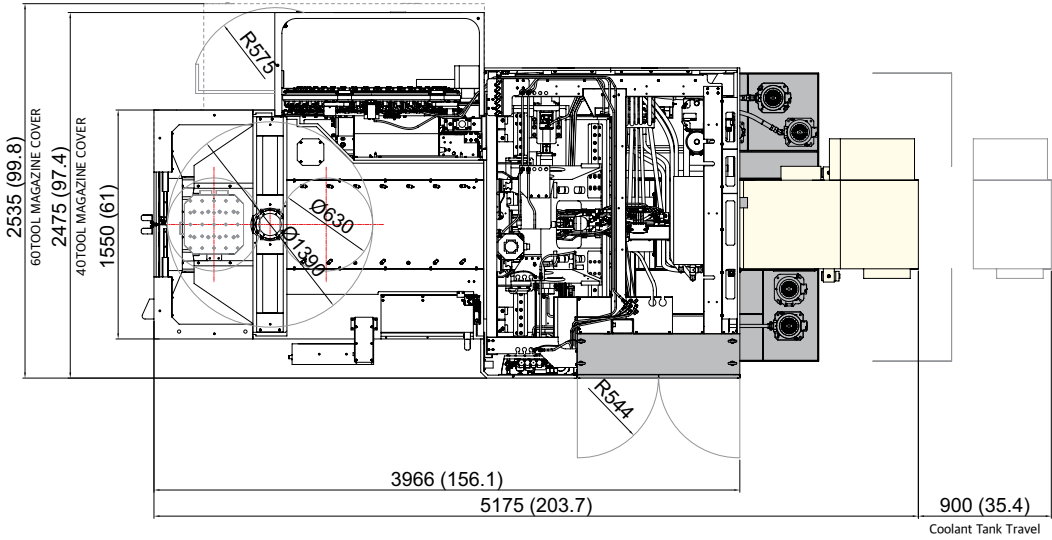

Specifications

External Dimensions

unit : mm(in)

HH50SMAX
HH50SMAX

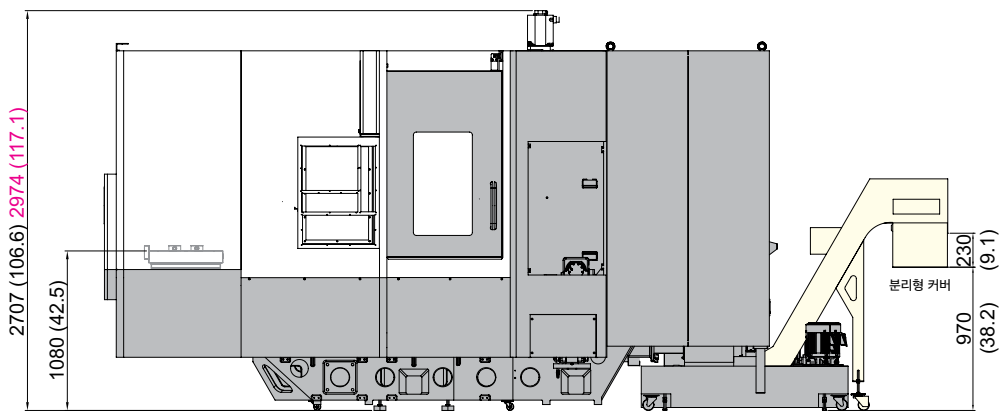
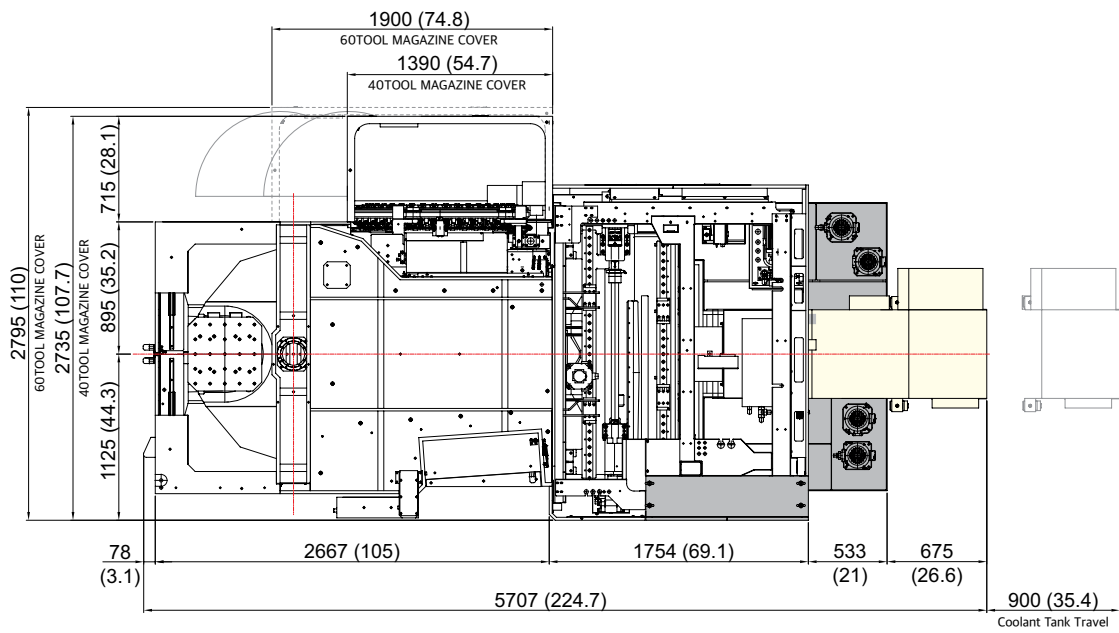

Specifications

Table Dimensions

unit : mm(in)

HH50SMAX | HH505SMAX

TAP

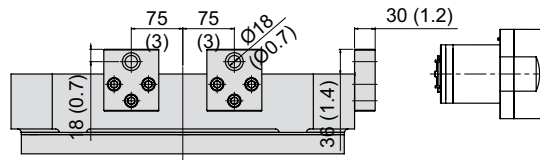
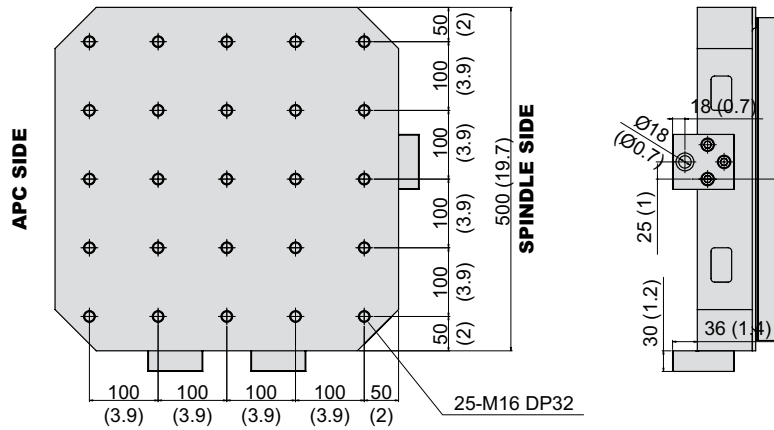

T-SLOT

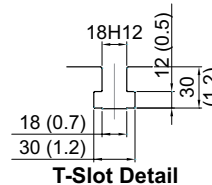
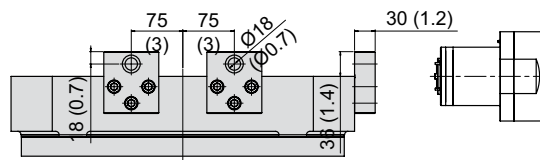
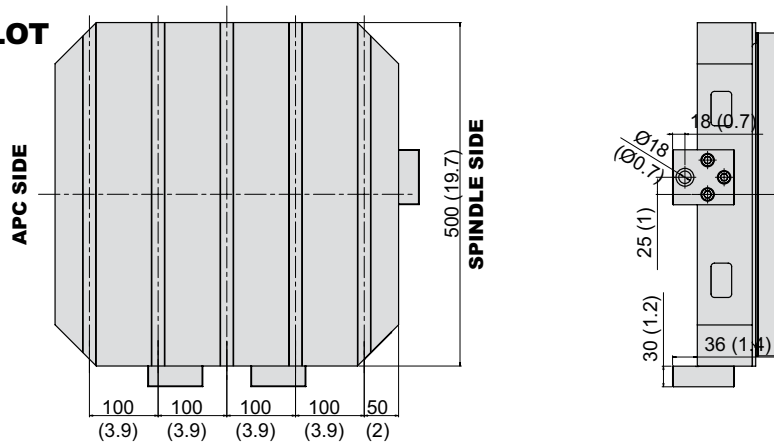

Specifications

Table Dimensions

unit : mm(in)

HH40SMAX | HH50SMAX

BT40/BBT40, BIG PLUS

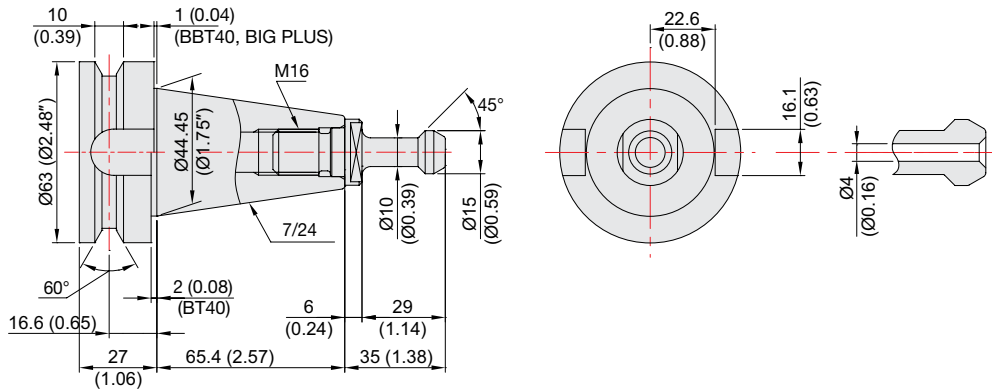

HSK A-63

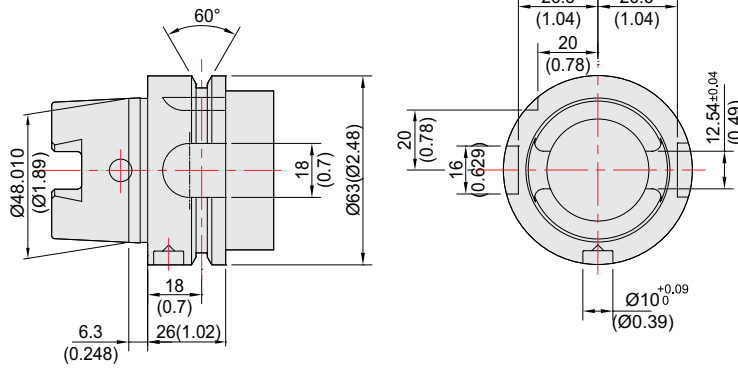

CAT40/BCV40

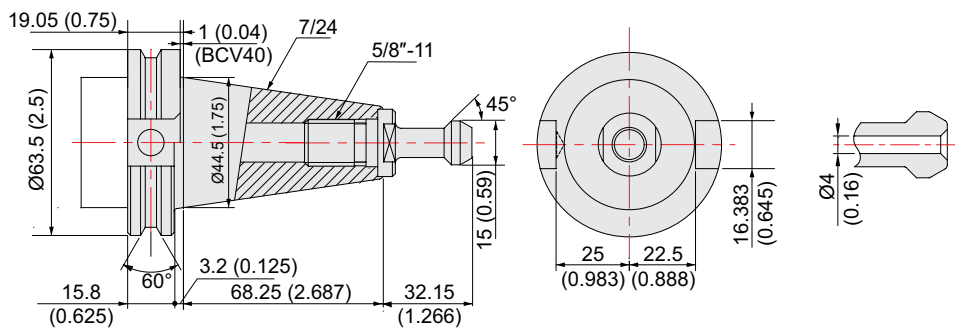

Specifications

Table Dimensions

unit : mm(in)

HH505SMAX

BT50/BBT50, BIG PLUS

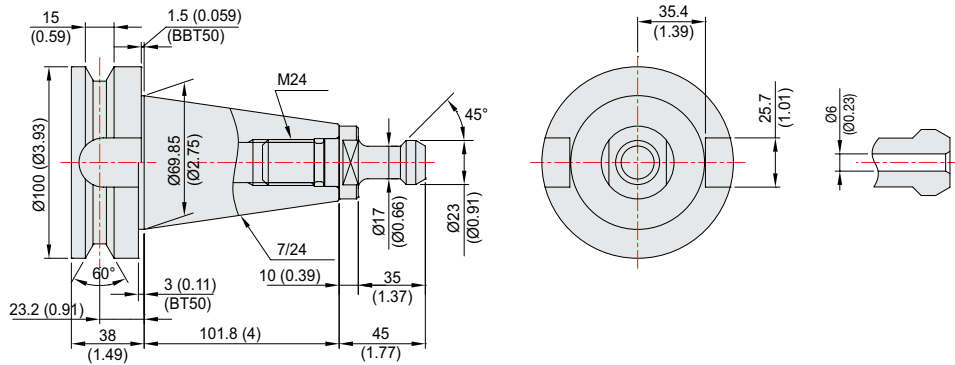

HSK A-100

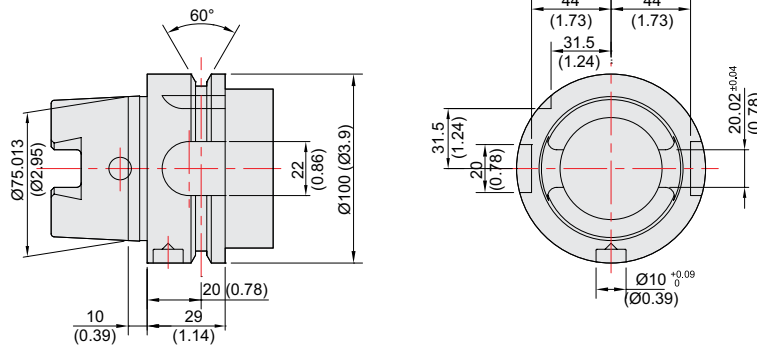

CAT50/BCV50

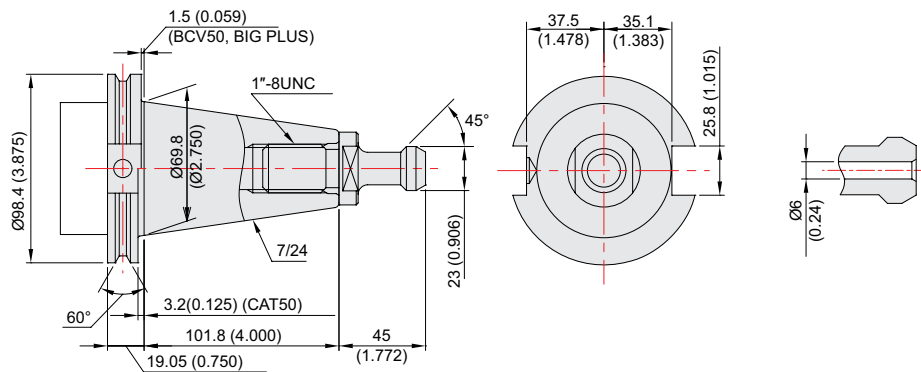

Specifications

Specifications

[] : Option

ITEM		HH40SMAX	HH50SMAX	
PALLET	Pallet Size (L×W)	mm(in)	2 - 400×400 (2-15.7"×15.7")	2-500×500 (2-19.7"×19.7")
	Maximum Load Capacity	kg(lbf)	2 - 400 (2 - 882)	2 - 500 (2 - 1,102)
	Maximum Workpiece Size	mm(in)	Ø630×H900 (24.8"×H35.4")	Ø800×H1,000 (Ø31.5"×H39.4")
	Min. Indexing Angle	deg	1° [0.001°]	
SPINDLE	Spindle Taper	-	BBT40 [HSK-A63]	
	Spindle RPM	r/min	15,000 [15,000 High-Torque] [20,000]	
	Spindle Motor Output (Max./Cont.)	kW(HP)	30/18.5 (40/25) [37/22 (50/30)] [37/18.5 (50/25)]	
	Spindle Torque (Max./Cont.)	N·m(lbf·ft)	230/119 (169.6/87.8) [303/119 (223.5/87.8)] [221/79.6 (163/58.7)]	
	Spindle Driving Method	-	Built-in	
FEED	Travel (X/Y/Z axis)	mm(in)	560/640/660 (22"/25.2"/26")	730/730/880 (28.7"/28.7"/34.6")
	Distance from Table Top to Sp. Center	mm(in)	80 ~ 720 (3.1" ~ 28.3")	80 ~ 810 (3.1" ~ 31.9")
	Rapid Traverse Rate (X/Y/Z)	m/min	60/60/60	
	Slide Type	-	Roller Guide	
ATC	Number of Tools	EA	Ring Type : 40 [60] [Chain Type : 90, 120] [Matrix : 240]	
	Tool Shank	-	BBT40 [HSK-A63]	
	Max. Tool Dia. (W.T/W.O)	mm(in)	Ø75/Ø170 (Ø3"/Ø6.7")	
	Max. Tool Length	mm(in)	450 (17.7")	550 (21.7")
	Max. Tool Weight	kg(lb)	12 (26.5)	
	Tool Selection Method	-	Ring Type : Random [Chain Type : Fixed]	
	Tool Change Time	T-T	sec	0.9
C-C		sec	2.3	2.6
APC	No. of Pallet	ea	2	
	APC Type	-	Direct Turn	
	Pallet Change Time (Vacant)	sec	* 8.0	* 9.2
TANK CAPACITY	Coolant Tank	ℓ(gal)	600 (158.5)	
	Lubricating Tank	ℓ(gal)	0.7 (0.2)	
	Hyd. Tank Unit	ℓ(gal)	20 (5.3)	
POWER SUPPLY	Air Consumption (0.5MPa)	ℓ /min(gal/min)	500 (132.1)	
	Electric Power Supply	kVA	46.4 [49.4]	
	Thickness of Power Cable	mm ²	Over 35	
	Voltage	V/Hz	220/60 (200/50*)	
MACHINE	Floor Space (L×W)	mm(in)	2,475×3,966 (97.4"×156.1")	2,719×4,402 (107"×173.3")
	Height	mm(in)	2,621 (103.2")	2,707 (106.6")
	Weight	kg(lb)	9,500 (20,944)	11,500 (25,353)
CNC	Controller	-	FANUC 31i-B Plus	

* APC changing time can vary depending on the weight of work piece.

*) Using 50Hz voltage instead of 60Hz may lower the output of motors. (excluding servo motors and inverter motors)

Specifications are subject to change without notice for improvement.

Specifications

Specifications

[] : Option

ITEM			HH505SMAX
PALLET	Pallet Size (L×W)	mm(in)	2-500×500 (2-19.7"×19.7")
	Maximum Load Capacity	kgf(lbf)	2 - 1,000 (2 - 2,205)
	Maximum Workpiece Size	mm(in)	Ø900×H1,100 (Ø35.4"×H43.3")
	Min. Indexing Angle	deg	1° [0.001°]
SPINDLE	Spindle Taper	-	BBT50 [HSK-A100]
	Spindle RPM	r/min	10,000 [15,000]
	Spindle Motor Output (Max./Cont.)	kW(HP)	45/25 (60/33.5) [37/30 (50/40)]
	Spindle Torque (Max./Cont.)	N·m(lbf·ft)	623/305 (459.5/225) [398/191 (293.6/140.9)]
	Spindle Driving Method	-	BUILT IN
FEED	Travel (X/Y/Z axis)	mm(in)	800/800/880 (31.5"/31.5"/34.6")
	Distance from Table Top to Sp. Center	mm(in)	100 ~ 810 (3.9" ~ 31.9")
	Rapid Traverse Rate (X/Y/Z)	m/min	60/60/60
	Slide Type	-	ROLLER GUIDE
ATC	Number of Tools	EA	Ring Type : 40 [Chain Type : 60, 90, 120] [Matrix : 240]
	Tool Shank	-	BBT50 [HSK-A100]
	Max. Tool Dia. (W.T/W.O)	mm(in)	Ø125/Ø320 (Ø4.9"/Ø12.6")
	Max. Tool Length	mm(in)	530 (20.9")
	Max. Tool Weight	kg(lb)	25 (55)
	Tool Selection Method	-	Ring Type : Random [Chain Type : Fixed]
	Tool Change Time	T-T	sec
C-C		sec	4.0
APC	No. of Pallet	ea	2
	APC Type	-	ROTARY TURN
	Pallet Change Time (Vacant)	sec	* 10
TANK CAPACITY	Coolant Tank	ℓ(gal)	600 (158.5)
	Lubricating Tank	ℓ(gal)	1.8/0.7 (0.5/0.2) : GREASE
	Hyd. Tank Unit	ℓ(gal)	20 (5.3)
POWER SUPPLY	Air Consumption (0.5MPa)	ℓ / min(gal/min)	500 (132.1)
	Electric Power Supply	kVA	53.2
	Thickness of Power Cable	mm ²	Over 50
	Voltage	V/Hz	220/60 (200/50*)
MACHINE	Floor Space (L×W)	mm(in)	3,061×4,962 (120.5"×195.4")
	Height	mm(in)	2,974 (117.1")
	Weight	kg(lb)	16,000 (35,274)
CNC	Controller	-	FANUC 31i-B Plus

* APC changing time can vary depending on the weight of work piece.

*) Using 50Hz voltage instead of 60Hz may lower the output of motors. (excluding servo motors and inverter motors)

Specifications are subject to change without notice for improvement.

Controller

FANUC 31i-B Plus

[] : Option ☆ Needed technical consultation

Controlled axis / Display / Accuracy Compensation	
Control axis	4 axis (X, Y, Z, B)
Simultaneously controlled axis	3 axis [Max. 4 axis]
Least setting Unit	X, Y, Z axis : 0.001 mm (0.0001 inch) B axis : 1 deg [0.001] deg
Least input increment	X, Y, Z axis : 0.001 mm (0.0001 inch) B axis : 1 deg [0.001] deg
Inch / Metric conversion	G20 / G21
High response vector control	
Interlock	All axis / Each axis
Machine lock	All axis
Backlash compensation	± 0 ~ 9999 pulses (Rapid traverse / Cutting feed)
Position switch	
LCD / MDI	15" color LCD with Touch screen
Feedback	Absolute motor feedback
Stored stroke check 1	Over travel
Stored stroke check 2, 3	
Pitch error compensation	
Operation	
Automatic operation (Memory)	
MDI operation	
DNC operation	Needed DNC software / CF card
Program restart	
Wrong operation prevention	
Program check function	Dry run, Program check Z axis Machine lock, Stroke check before move
Single block	
Search function	Program Number / Sequence Number
Retraction for rigid tapping	
Manual guide i	Smart Guide i
Interpolation functions	
Nano interpolation	
Positioning	G00
Linear interpolation	G01
Cylindrical interpolation	G02, G03
Exact stop mode	Single : G09, Continuous : G61
One-way positioning	G60
Inverse-time feed	G93
Dwell	G04, 0 ~ 9999.9999 sec
Skip	G31
Reference position return	1st reference : G28 2, 3, 4 reference : G30 P2, P3, P4 Ref. position check : Z7
Thread synchronous cutting	G33
Helical interpolation	Circular + Linear interpolation 2 axis(max.)
Feed function / Acc. & Dec. control	
Rapid traverse	
Manual feed	Jog : 0~5,000mm/min (197 ipm) Manual handle : x1, x10, x100 pulses Reference position return
Cutting Feed command	Direct input F code
Feedrate override	0 ~ 200% (10% Unit)
Rapid traverse override	F0% (F1%), F25%, F50%, F100%
Override cancel	
Feed per minute	G94
Feed per revolution	G95
Look-ahead block	1,000 Block
Program input	
Tape Code	EIA / ISO
Optional block skip	9 ea
Absolute / Incremental program	G90 / G91
Program stop / end	M00, M01 / M02, M30
Maximum command unit	± 999,999.999 mm (± 99,999.9999 inch)
Plane selection	X-Y : G17 / Z-X : G18 / Y-Z : G19
Workpiece coordinate system	G52, G53, 48 pairs (G54.1 P1 ~ P48)
Manual absolute	Fixed ON
Programmable data input	G10
Sub program call	10 folds nested
Custom macro	#100~#199, #500~#599, #98000~#98499
Programmable mirror image	G51.1, G50.1

Controlled axis / Display / Accuracy Compensation	
Polar coordinate command	G15, G16
Do not look ahead function	G4.1
Including Chamfering / Corner R	
Canned cycle	G73, G74, G76, G80 ~ G89
Coordinate rotation	G68, G69
Scaling	G50, G51
Auxiliary function / Spindle speed function	
Auxiliary function	M 4 digit
Level-up M Code	Multi / By-Pass
Spindle speed command	S 5 digit , Binary output
Spindle override	50% ~ 120% (10% Unit)
Spindle orientation	M19
FSSB high speed rigid tapping	
Tool function / Tool compensation	
Tool function	Max. T 8 digit
Tool life management	256 pairs ☆
Tool offset pairs	400 pairs
Tool nose radius compensation	G40, G41, G42
Tool nose length compensation	G43, G44, G49
Tool offset memory C	Tool length, diameter, abrasion (Length/Dia.)
Tool length measurement	Z axis Input C
Editing function	
Part program storage size	10240m (4MB)
No. of registerable programs	1,000 ea
Program protect	
Background editing	
Extended part program editing	
Memory card program edit	Copy, move and change of file program
Protection of data at 8 levels	
Data input / output & Interface	
I/O interface	Memory card, USB memory interface Embedded Ethernet interface
Screen hard copy	
External message	
External key input	
External workpiece number search	
Automatic data backup	
Setting, display and diagnosis	
Self-diagnosis function	
History display	Alarm & Operator message & Operation
Run hour / Parts count display	
Maintenance information	
Actual cutting feedrate display	
Display of spindle speed / T code	
Graphic display	
Operating monitor screen	
Power consumption monitoring	Spindle & Servo
Multi language display	Support 25 languages
Display language switching	Selection of 5 optional Languages
LCD Screen Saver	Screen saver
Macro Excutor	Custom software 8MB (WIA Screen)☆
Processing select	Speed/ridigity setting
Option	
Fast ethernet	Needed option board
Data server	Needed option board (1GB, 2G, 4GB)
Sub Spindle control	☆
Polar coordinate interpolation	G12.1, G13.1
Cylindrical interpolation	G07.1
Manual handle feed	2/3 units
Tool offset number	Max. 2,000 pair
Program storage capacity	~32MByte
Program registration number	Max. 4,000 ea
Additional work coordinate	300 pair (G54.1 P1 ~ P300)

Figures in inch are converted from metric values.

The FANUC controller specifications are subject to change based on the policy of company CNC supplying.

SGWIA ECO SYSTEM

MQL (Minimal Quantity Lubrication)

The goal of this system is to spray only the amount of lubricant required to prevent heat and chip build up at the cutting tool or work piece face.

Example of Machining Center Application

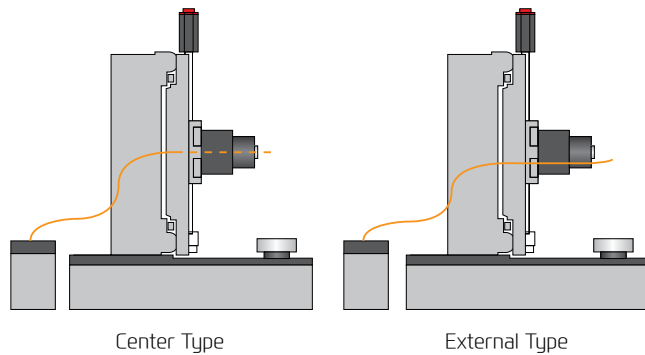

Example of Etc.

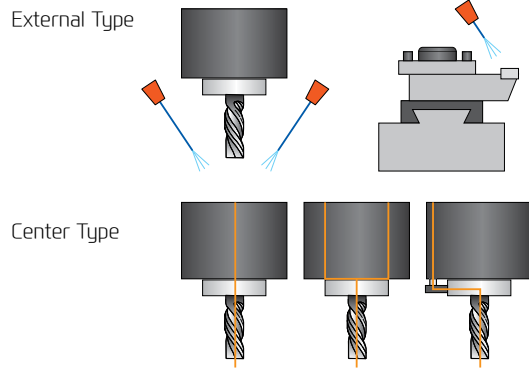

Oil Skimmer

An oil skimmer can increase coolant and tool life by removing tramp oil contaminants.



Mist Collector

Mist Collector reduces the amount of smoke and oil mist in the air. This helps build a safe and comfortable working environment and improve durability.

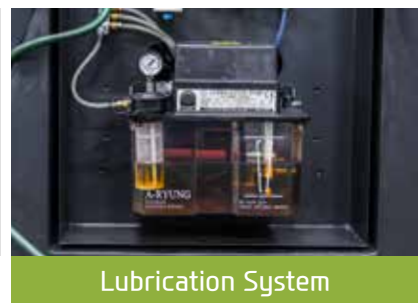

Lubrication System

By applying lubricant only when the machines axis are moving lubrication consumption is reduced by compared to standard systems.

SGWIA ENERGY SAVING

HW-ESS (SGWIA Energy Saving System)

SGWIA Machine tool provides the optimum power saving function that can easily save energy with an intuitive user interface.



1. **Machine-ready power saving function** : Put all servo motors and other motors into sleep mode when no control or operation is done for a set time
2. **Work light auto-off function** : The work light is turned off automatically when no control or operation is done for a set time
3. **Chip conveyor auto power saving** : Operation/non operation time (timer) can be set to save energy
4. **Auto Power-off** : Auto power off after ending the an operation after a period of time
5. **Eco function** : Machine ready sleep mode can be activated/de-activated from the controller panel
6. **Power consumption monitor** : Real time power consumption can be monitored through the OP screen