

HH63/80S MAX

Next-Generation High-speed Horizontal Machining Center

SGWIA Horizontal Machining Center

Technical Leader

Horizontal Machining Center HH63/80SMAX, designed by SGWIA with years of expertise and the latest technology, provides high speed, high performance and maximum productivity.

		HH63S MAX	HH80SMAX
Pallet Size (L×W)	mm(in)	2-630×630 (24.8"×24.8")	2-800×800 (31.5"×31.5")
Max. Load Capacity	kg(lb)	2-1,500 (3,307)	2-2,000 (4,409)
Spindle Taper	-	BBT50 [HSK-A100]	
Spindle Speed	r/min	10,000 [15,000] [6,000]	
Spindle Output (Max./Cont.)	kW(HP)	45/25 (60/33.5) [37/30 (50/40)] [55/30 (74/40)]	
No. of Tools	EA	40 [60, 90, 120, 150] [Matrix : 240 ~]	
Travel (X/Y/Z)	mm(in)	1,050/900/1,000 (41.3"/35.4"/39.4")	1,400/1,200/1,370 (55.1"/47.2"/53.9")
Rapid Traverse Rate (X/Y/Z)	m/min(ipm)	60/60/60 (2,362/2,362/2,362)	50/50/50 (1,969/1,969/1,969)

[] : Option

- High Rigidity Box-type Structure
- A symmetrical structure design with the center of gravity of Z-axis and transfer axis matching
- Easy chip disposal with direct chip discharging structure
- Best-in-class rapid traverse rate of 60m/min (2,362ipm)
- Machining of the largest workpiece in its class
- ATC design capable of attaching the largest tools in its class



01 BASIC STRUCTURE

High Quality & Productivity Horizontal Machining Center

ATC & Magazine

- No. of Tools : 40 [60/90/120/150] EA (MATRIX : 240 EA)
- Tool Selection Method : Fixed

High Precision Spindle

- Built-in Spindle : 10,000 r/min
- Oil Cooling System
- BBT50 [HSK-A100]

Pallet

- Pallet Size (X/Y)
HH63S MAX : 630×630 mm (24.8"×24.8")
HH80SMAX : 800×800 mm (31.5"×31.5")- Air
Clearing System



15" Large Monitor Applied

The HH63/80SMAX has a 15" large monitor for enhanced visibility. In particular, we can create more convenient use conditions by improving the operating environment such as program setup and simulation through a large screen.

HIGH RIGIDITY BOX-TYPE STRUCTURE

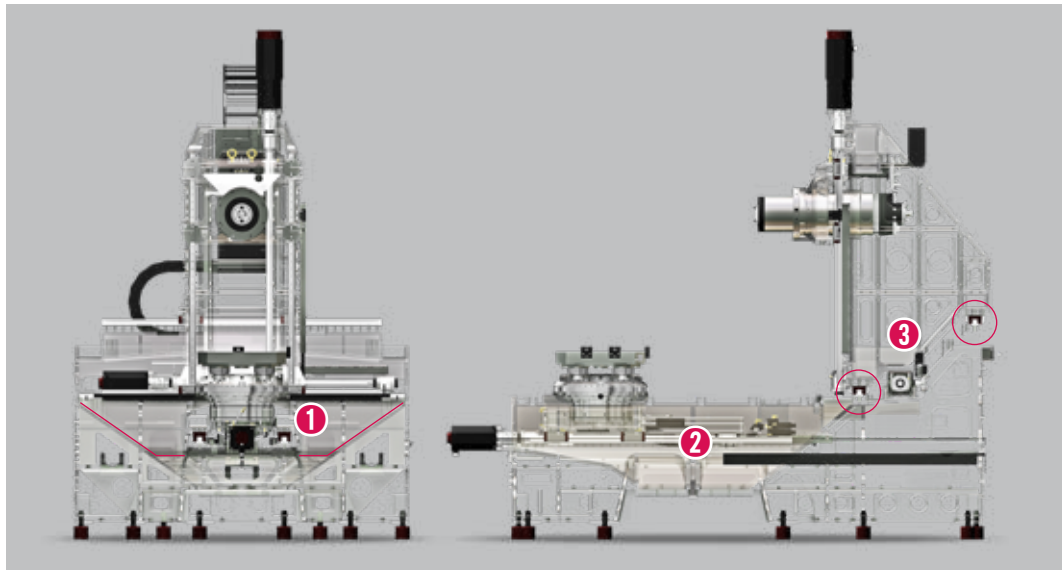

① Highly Rigid Box-type Bed

Unlike the previous reverse T-shaped structures, HH63/80SMAX has a horizontally symmetrical design with the Z-axis transfer system at the center of the material. In particular, a boxed bed design with extremely high rigidity not only secured the structural stability but also improved vibration absorption, enabling ample medium cutting and excellent illumination for machining with a symmetrical structure on the Z-axis.

② Changed Chip Disposal Structure

Designed to directly drop chips onto the chip conveyor, HH63/80SMAX enables seamless chip disposal even during mass chip generation. (Chip processing capability has been greatly improved compared to the screw-type chip conveyor in existing machines.)

③ Step Type Bed Structure

It is designed to minimize the load occurring at the front. Also, travel stability is increased by column weight optimization.

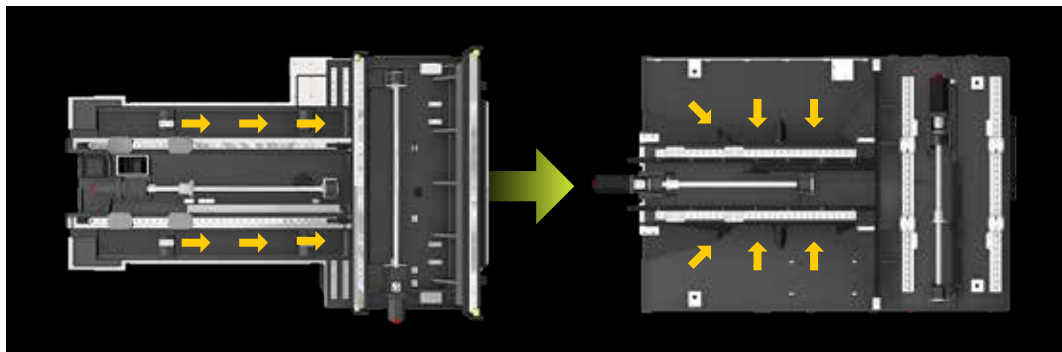

<Reversed 'T' Type Bed>

<HH63S MAX 'Box' Type Bed>

02 HIGH-SPEED FEED

Highest Quality, High-speed Horizontal Machining Center



High-Speed Roller Type Guideway

Linear roller guideways are applied to reduce non-cutting time and bring high rigidity. Each axis is directly connected to a highly reliable digital servo motor to provide high rigidity and minimal thermal displacement.



Large Ball Screw

The increased diameters of all ball screws allow for high accuracy even during heavy duty machining.



Linear Scale **OPTION**

Linear scales on all axis providing high precision positioning accuracy and compensates for ball screw thermal displacement ensuring extremely precise machining.

In addition, the absolute type linear scale is installed in close proximity to the ball screw of each axis.

Travel (X/Y/Z) HH63SMAX

1,050/900/1,000 mm
(41.3"/35.4"/39.4")

Travel (X/Y/Z) HH80SMAX

1,400/1,200/1,370 mm
(55.1"/47.2"/53.9")

◎ HH80SMAX Expansion of Transfer Distance

X-axis	1,050 mm (41.3")	1,400 mm (55.1")	350 mm (13.8")
Y-axis	875 mm (34.4")	1,200 mm (47.2")	325 mm UP (12.8")
Z-axis	875 mm (34.4")	1,370 mm (53.9")	495 mm UP (19.5")
	Previous model	HH80SMAX	



Basic Structure

HIGH-PRECISION & HIGH-SPEED

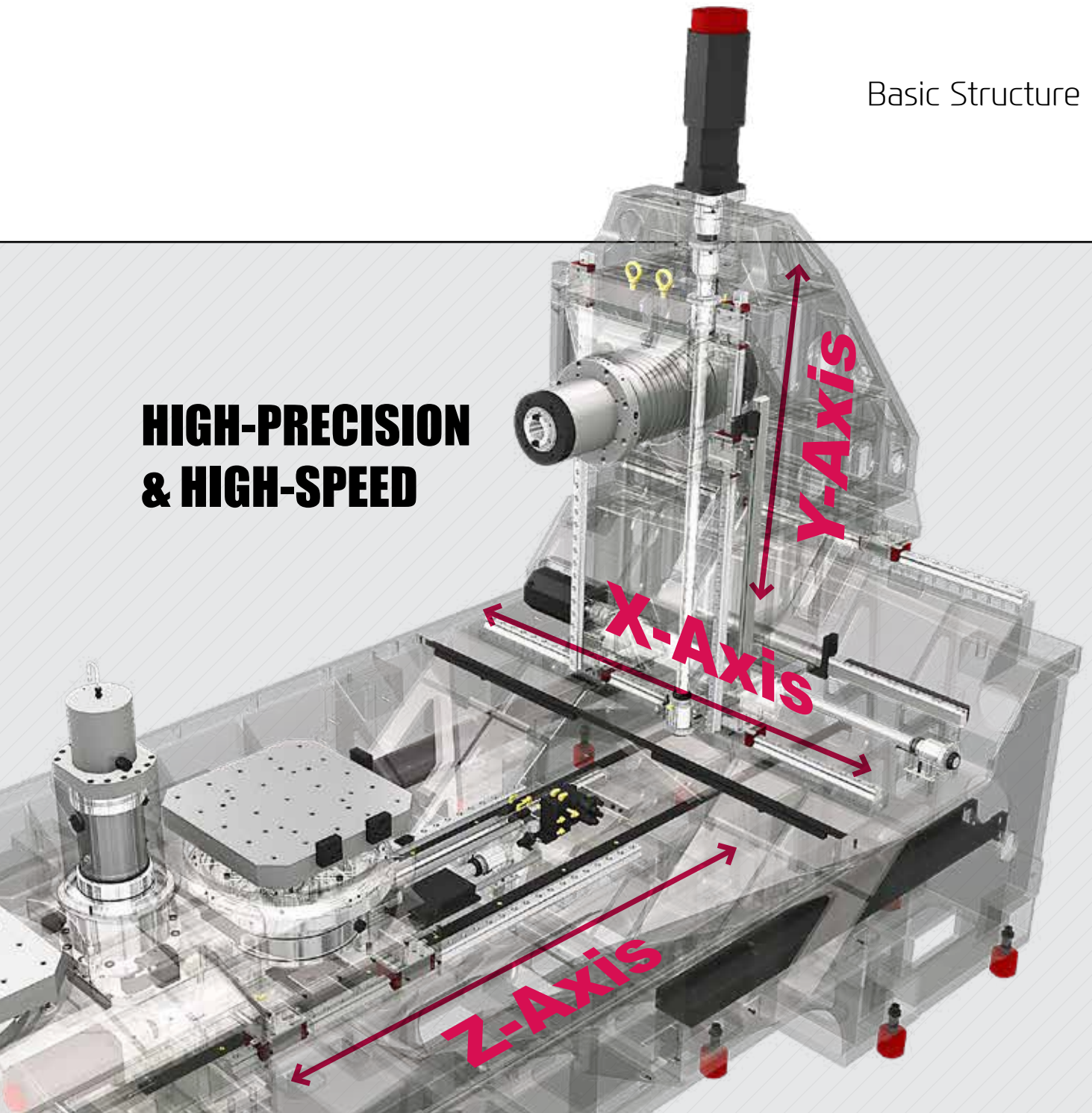

Rapid Traverse Rate (X/Y/Z) HH63SMAX

60/60/60 m/min
(2,362/2,362/2,362 ipm)

Distance from Table Top to Sp. Center

75 mm (3")

Rapid Traverse Rate (X/Y/Z) HH80SMAX

50/50/50 m/min
(1,968/1,968/1,968 ipm)

03 HIGH PRECISION SPINDLE

Excellent machining performance with high-precision spindle

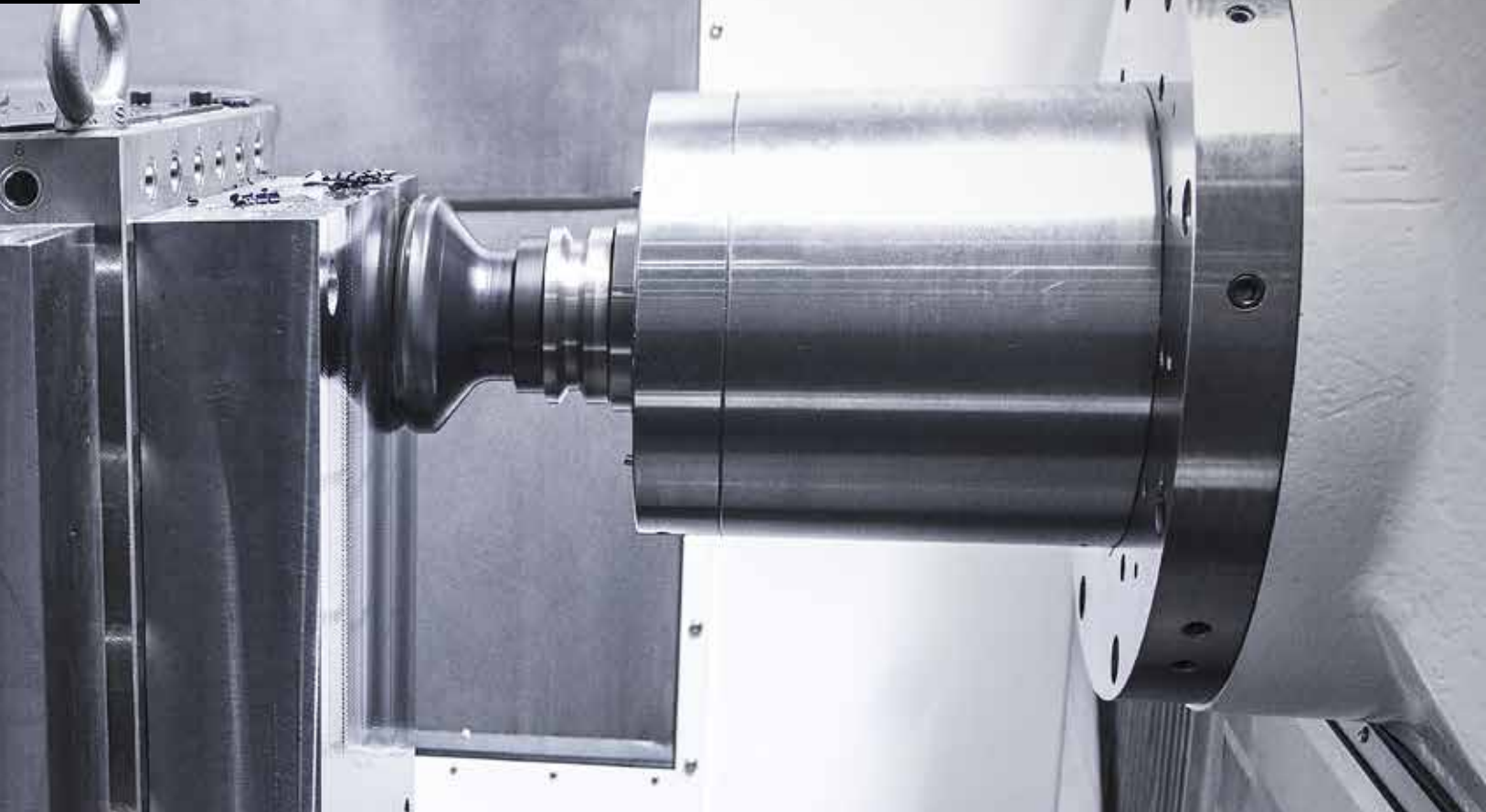

The secret to maintaining high quality even during a long-term machining, starts with the performance of the spindle.

HH63/80SMAX incorporated a high performance built-in spindle as a standard.

The built-in spindle, with the spindle and motor combined, exhibits superior performance during high speed rotations, minimizing vibration.

In addition, HH63/80SMAX will realize the best-in-class acceleration and deceleration time of the spindle, contributing to improved productivity. By improving the acceleration performance of the spindle motor compared to competition models, it has shortened the time to reach the RPM necessary for machining, and the tool exchange time has been greatly improved by minimizing the spindle motor down time

◎ Spindle Acceleration (0 → 10,000 rpm)

Previous model	7 sec
HH63SMAX	3.4 sec 3.6 sec reduction

High performance spindle of HH63/80SMAX, developed in consideration of even high quality performance and productivity, This is the main feature of HH63/80SMAX.

HIGH-SPEED, HIGH-POWER BUILT-IN SPINDLE

SPINDLE

Built-in Spindle

By using ultra precision class angular ball bearings, fast acc/deceleration of the main spindle is achieved. The spindle head is designed to minimize heat displacement therefore reducing heat generation and making it possible to maintain high accuracy.

Oil Cooling System.

Spindle temperature is controlled by the use of a spindle oil chiller. This ensures consistent spindle temperature which minimizes thermal displacement.

Through Spindle Coolant (20/30/70 bar) **OPTION**

Through Spindle Coolant is exceedingly useful when drilling deep holes. It helps increase the lifetime of the tool, while decreasing cycle time.



Dual contact Spindle

The Big Plus spindle system (BBT#50) provides dual contact between the spindle face and the flange face of the tool holder.

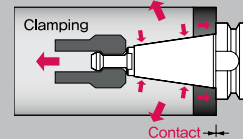

Spindle Specifications

Speed (rpm)	Motor (Max./Cont.)	Torque (Max./Cont.)	Type
10,000 rpm	45/25 kW (60/33.5 HP)	623/305 N·m (459.5/225 lbf-ft)	[] : Option
[15,000 rpm]	[37/30 kW (50/40 HP)]	[398/191 N·m (293.6/140.9 lbf-ft)]	Built-in
[6,000 rpm]	[55/30 kW (74/40 HP)]	[807/353 N·m (595.2/260.4 lbf-ft)]	

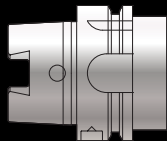

HSK Tool Holder **OPTION**

HSK tool holder is utilized for precise positioning with less expansion in the spindle taper during high speed rotation. This ensures an excellent level of precision for high precision machining.

04 APC & PALLET

Productivity improvement through servo motor drive type APC

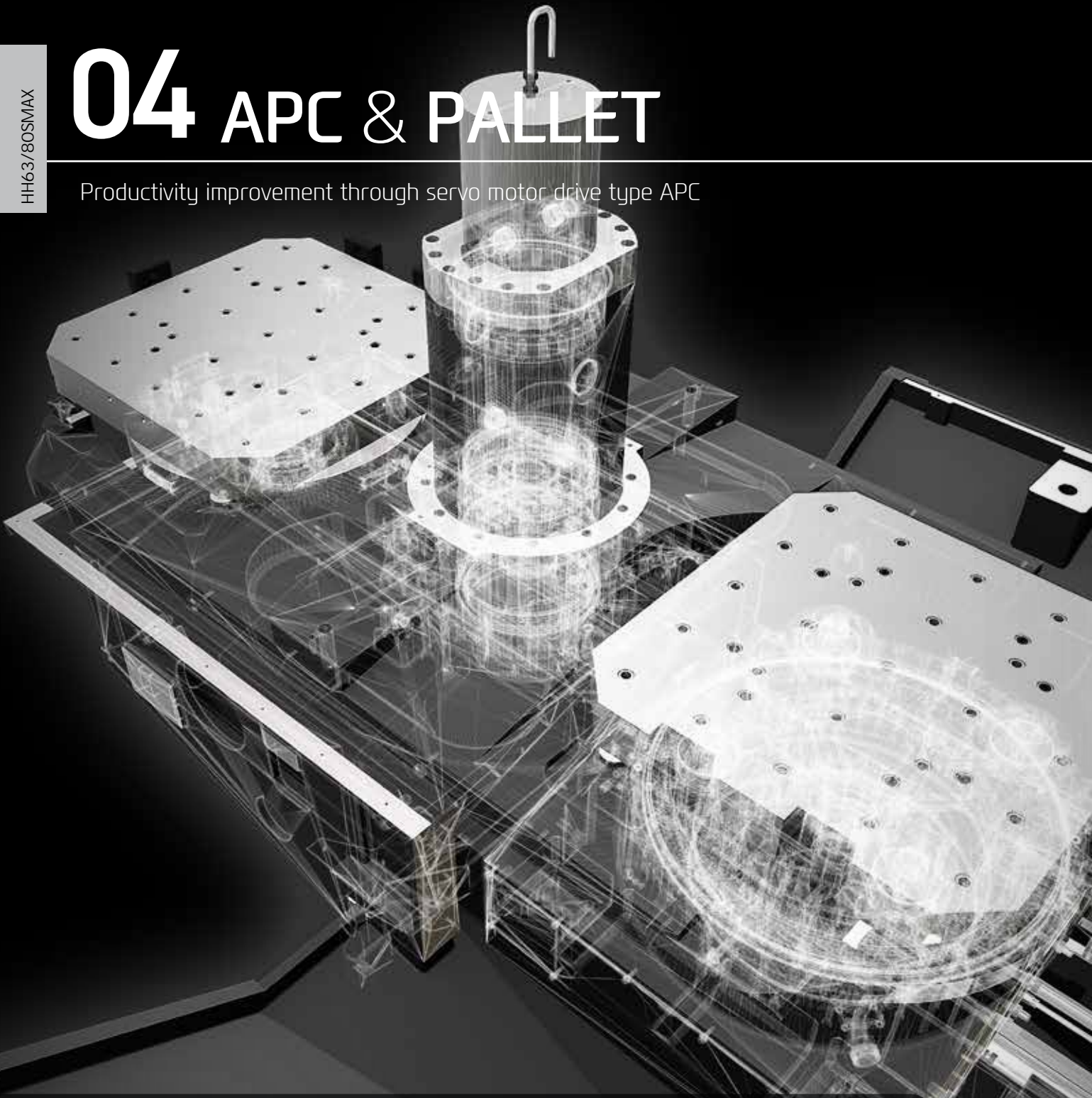

APC & Pallet Specifications

Model	Pallet Size	Max. Load Capacity	Min. Indexing Angle	APC Type
HH63SMAX	2 - 630×630 mm (24.8"×24.8")	2 - 1,500 kg (3,307 lb)	1° [0.001°]	Direct Turn
HH80SMAX	2 - 800×800 mm (31.5"×31.5")	2 - 2,000 kg (4,409 lb)	1° [0.001°]	

HIGH RIGIDITY & HIGH SPEED PALLET EXCHANGE SYSTEM

APC

High Speed APC

HH63/80SMAX provides a lift rotary type APC(automatic pallet changer) as standard. The loading station pallet can be rotated and locked in 90° increments for convenient loading/unloading of workpieces.

APC Change Time	12 SEC (Vacant)
Previous Machine	16 sec
HH63SMAX	12 sec 4 sec reduction

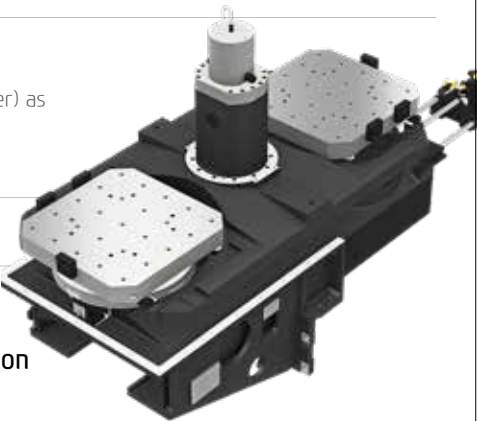

PALLET

High Precision Pallet

Inside the cones, there are clamping devices for powerful clamping of pallets which is suitable for heavy duty cutting. 1° (0.001° Opt.) index table is applied with high precision curvic coupling for accurate indexing.

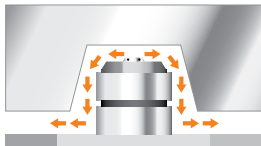

Air Clearing System

During the pallet change cycle, strong air blasts from the taper cones on the machine table help remove chips and provide clean surfaces for locating the pallet. This ensures high accuracy of pallet positioning and guarantees optimum rigidity.

Largest Workpiece Machining

HH63SMAX	Max. dia. $\varnothing 1,050\text{mm}$ ($\varnothing 41.3''$) Max. length 1,400mm (55.1'')	Weight: 1,500KG (3,307 lb)
HH80SMAX	Max. dia. $\varnothing 1,470\text{mm}$ ($\varnothing 457.9''$) Max. length 1,600mm (63'')	Weight: 2,000KG (4,409 lb)

⦿ Increase Machining Area

Previous model	Max. Dia.	$\varnothing 930\text{mm}$ (36.6'')
HH63SMAX	Max. Dia.	$\varnothing 1,050\text{mm}$ (41.3'')
Previous model	Max. Length	1,000 mm (39.4'')
HH63SMAX	Max. Length	1,400 mm (55.1'')

05 ATC & MAGAZINE

High Productivity Achieved with High Rigidity, Accuracy Machining

ATC & Magazine Specifications <Largest tool size and weight in its class : Std.>

[] : Option

Model	No. of Tools	Max. Tool Dia. (W.T/W.O)	Max. Tool Length	Max. Tool Weight
HH63/80SMAX	40 [60, 90, 120, 150] EA	Ø135/Ø320 mm (Ø5.3"/Ø12.6")	630 mm (24.8")	30 kg (66.1 lb)

❖ No. of Tools - Matrix Magazine : 240 EA (Option)

HIGH RIGIDITY, TOOL CHANGE SYSTEM

ATC & MAGAZINE

High Speed Servo Motor ATC

The tool magazine holds 40 tools as standard and up to 150 tools as an option depending on the model.

Servo control, fixed address tool selection method and a separate magazine control panel enhance user convenience. The twin arm ATC provides fast and reliable tool change to reduce non-cutting time.

⊙ Improved Tool Change time (C-C)

Previous model	7.0 sec
HH63SMAX	4.9 sec

2.1 sec reduction



Max. Tool Dia. / Length

Ø320/630 mm

Max. Tool Weight

30 kg (40 ~ 150 Tool)



Expand Tool Selection

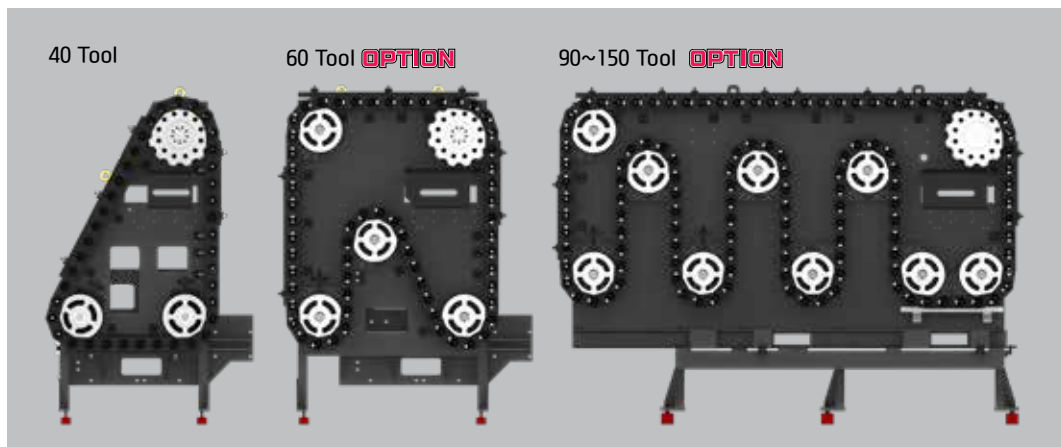

❖ Matrix Magazine : 240 Tool (When PLS is Applied)

06 AUTOMATION SYSTEM

Automatic Solutions to Improve Productivity

High level of automation system with multi-level pallet rack

SGWIA PLS is an unmanned automation system for horizontal machining centers with two-storied pallet stackers to achieve a reasonable installation area. Especially, it contributes to productivity improvement by easy and efficient system operation to flexibly respond to changes in production volume.

PLS (Pallet Line System)

Horizontal Machining Center (HH63SMAX)



Loading Station

PALLEX (Operating S/W)



Matrix ATC



PLS (Pallet Line System)

ITEM		HH63SMAX
Pallet Size	mm(in)	Ø630 (Ø24.8")
Max. Load Capacity	kg(lb)	1,500 (3,307)
Max. Machining Dia.	-	Ø1,050 (Ø41.3")
Max. Machining Length	mm(in)	1,350 (53.1")
Po. of Pallet	EA	10~ 72 [☆81]
Po. of Loading Station	EA	1~4
Po. of Machine Tools	EA	1~7 [☆10]

[☆]: Prior consultation needed

MATRIX ATC

Po. of Tools	EA	240
Driving Method	-	Servo
Tool Selection Method	-	Fixed
Max. Tool Dia.	mm(in)	Ø135/Ø320 (Ø5.3"/Ø12.6")
Max. Tool Length	mm(in)	630 (24.8")
Max. Tool Weight	kg(lb)	30 (66.1)

SPECIFICATIONS

Standard & Optional

Spindle		HH63SMAX	HH80SMAX
10,000rpm (45/25kW)	Built-In	●	●
15,000rpm (37/30kW)	Built-In	○	○
6,000rpm (55/30kW)	Built-In	○	○
Spindle Cooling System		●	●
ATC			
ATC Extension	40	●	●
	60	○	○
	90	○	○
	120	○	○
	150	○	○
	240 (MatrixX)	○	○
Tool Shank Type	BBT50	●	●
	HSK-A100	○	○
	BCV50	○	○
Tool Weight	30kg	●	●
U-Center	D'andrea	☆	☆
Pull Stud	45°	●	●
Servo Motor Magazine		●	●
Table, APC & Pallet			
APC	Rotary Turn	●	●
Tap Type Pallet		●	●
T-Slot Pallet		○	○
B Axis Table	1°	●	●
	0.001°	○	○
Coolant System			
Std. Coolant (Nozzle)		●	●
Bed Flushing Coolant		●	●
*1) Through Spindle Coolant	20bar	○	○
	30bar, 20 ℓ (5.3 gel)	○	○
	70bar, 15 ℓ (4 gel)	○	○
	70bar, 20 ℓ (5.3 gel)	○	○
	70bar, 30 ℓ (7.9 gel)	○	○
Shower Coolant		○	○
Gun Coolant		○	○
Side Oil Hole Coolant		☆	☆
Air Gun		○	○
Cutting Air Blow		○	○
Tool Measuring Air Blow (Only for TLM)		○	○
Air Blow for Automation		☆	☆
Thru MQL Device (Without MQL)		☆	☆
Coolant chiller (Sub Tank)		☆	☆
Power Coolant System (For Automation)		☆	☆
Chip Disposal			
Coolant Tank	680 ℓ (180 gal)	●	●
Chip Conveyor (Hinge/Scraper)	Left / *1) Rear	○	○
Chip Conveyor (Magnetic)	Left / *1) Rear	○	○
Chip Conveyor (Mesh Drum)	Left / *1) Rear	○	○
Special Chip Conveyor (Drum Filter)		☆	☆
Chip Wagon	Standard (180 ℓ [47.5 gal])	○	○
	Swing (200 ℓ [52.8 gal])	○	○
	Large Swing (290 ℓ [76.6 gal])	○	○
	Large Size (330 ℓ [87.2 gal])	○	○
	Customized	☆	☆
S/W			
Dialogue Program (HW-DPRO)		○	○
DNC software (HW-eDNC)		○	○
Machine Monitoring System (HW-MMS Cloud)		☆	☆
Machine Monitoring System (Customer Installation : HW-MMS Edge)		☆	☆
Smart Guide-i : FANUC		☆	☆
Smart S/W		☆	☆

● : Standard ○ : Option ☆ : Prior Consultation - : Non Applicable

Safety Device		HH63SMAX	HH80SMAX
Total Splash Guard		●	●
Electric Device			
Call Light	1 Color : ●	●	●
Call Light & Buzzer	3 Color : ● ● ● B	○	○
Work Light		●	●
Electric Cabinet Light		○	○
Remote MPG		●	●
3 Axis MPG		○	○
Work Counter	Digital	○	○
Total Counter	Digital	○	○
Tool Counter	Digital	○	○
Multi Tool Counter	6 EA	☆	☆
	9 EA	☆	☆
Electric Circuit Breaker		○	○
AVR (Auto Voltage Regulator)		☆	☆
Transformer	65kVA	○	○
Auto Power Off		○	○
Back up Module for Black out		○	○
Measuring Device			
Air Zero	TACO	○	○
	SMC	○	○
Work Measuring Device		○	○
TLM	Touch	○	○
(Marposh/Renishaw/Blum)	Laser	○	○
Tool Broken Detecting Device		☆	☆
Linear Scale	X/Y/Z Axis	○	○
Pallet Close Confirmation Device		○	○
Coolant Level Sensor (Only for Chip Conveyor, Bladder Type)		☆	☆
Environment			
Air Conditioner		○	○
Dehumidifier		○	○
Oil Mist Collector		☆	☆
Oil Skimmer (Only for Chip Conveyor)		○	○
MQL (Minimal Quantity Lubrication)		☆	☆
Fixture & Automation			
Auto Door	Std.	○	○
	High Speed	☆	☆
Auto Shutter (Only for Automatic System)		-	-
Sub O/P		☆	☆
Control of Additional Axis	1Axis	☆	☆
	2Axis	☆	☆
External M Code 4EA		○	○
Automation Interface		☆	☆
I/O Extension (In & Out)	16Contact	☆	☆
	32Contact	☆	☆
6PPL		○	○
PLS		○	○
Hyd. Device			
Std. Hyd. Unit	70bar/45 ℓ (11.8 gal)	●	●
Center Type Hyd. Supply Unit (Upper)	2×2 (4P)	☆	☆
	2×4 (8P)	☆	☆
	2×8 (16P)	☆	☆
Center Type Hyd. Supply Unit (Lower)	6P (Standby Pallet)	☆	☆
	2×6 (12P)	-	-
Hyd. Unit for Fixture	45bar	☆	☆
	70bar	☆	☆
	100bar	☆	☆
	Customized	☆	☆
ETC			
Tool Box		●	●
Customized Color	Need for Munsel No.	☆	☆
CAD&CAM Software		☆	☆

*1) Through Spindle Coolant : Please check the filter types with sales representative. *2) Chip Conveyor : When ordering a rear chip conveyor, prior consult with hyudai wa's sales person. Specifications are subject to change without notice for improvement. / Please refer to the S/W catalog (iRIS) for details by S/W product.

SPECIFICATIONS

Spindle Output/Torque Diagram

Built-in 10,000rpm

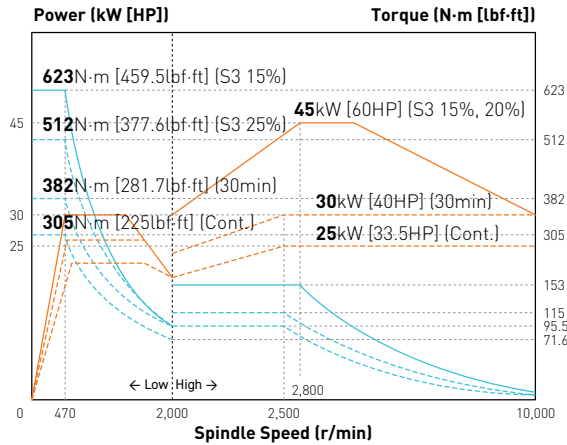

Built-in 15,000rpm

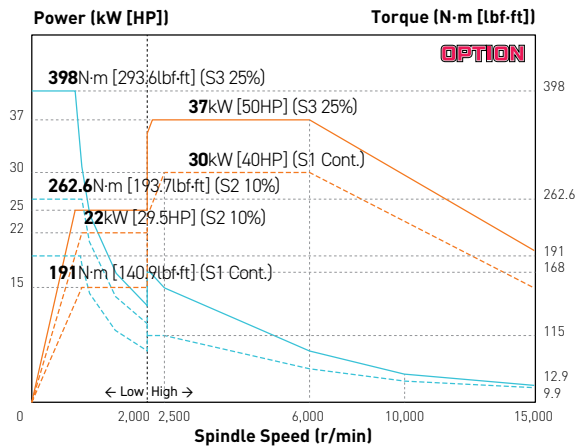

Built-in 6,000rpm

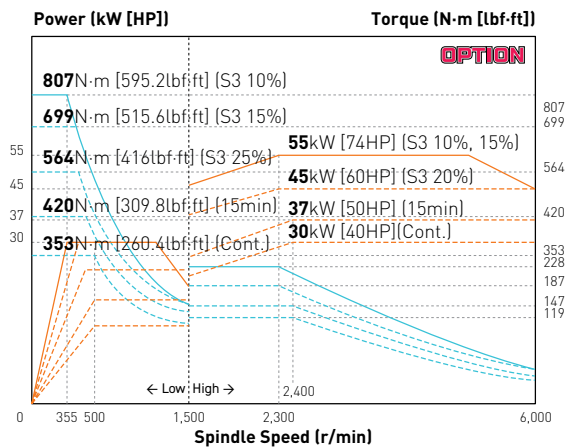

SPECIFICATIONS

External Dimensions

unit : mm(in)

HH63SM
AX
HH80SM
AX

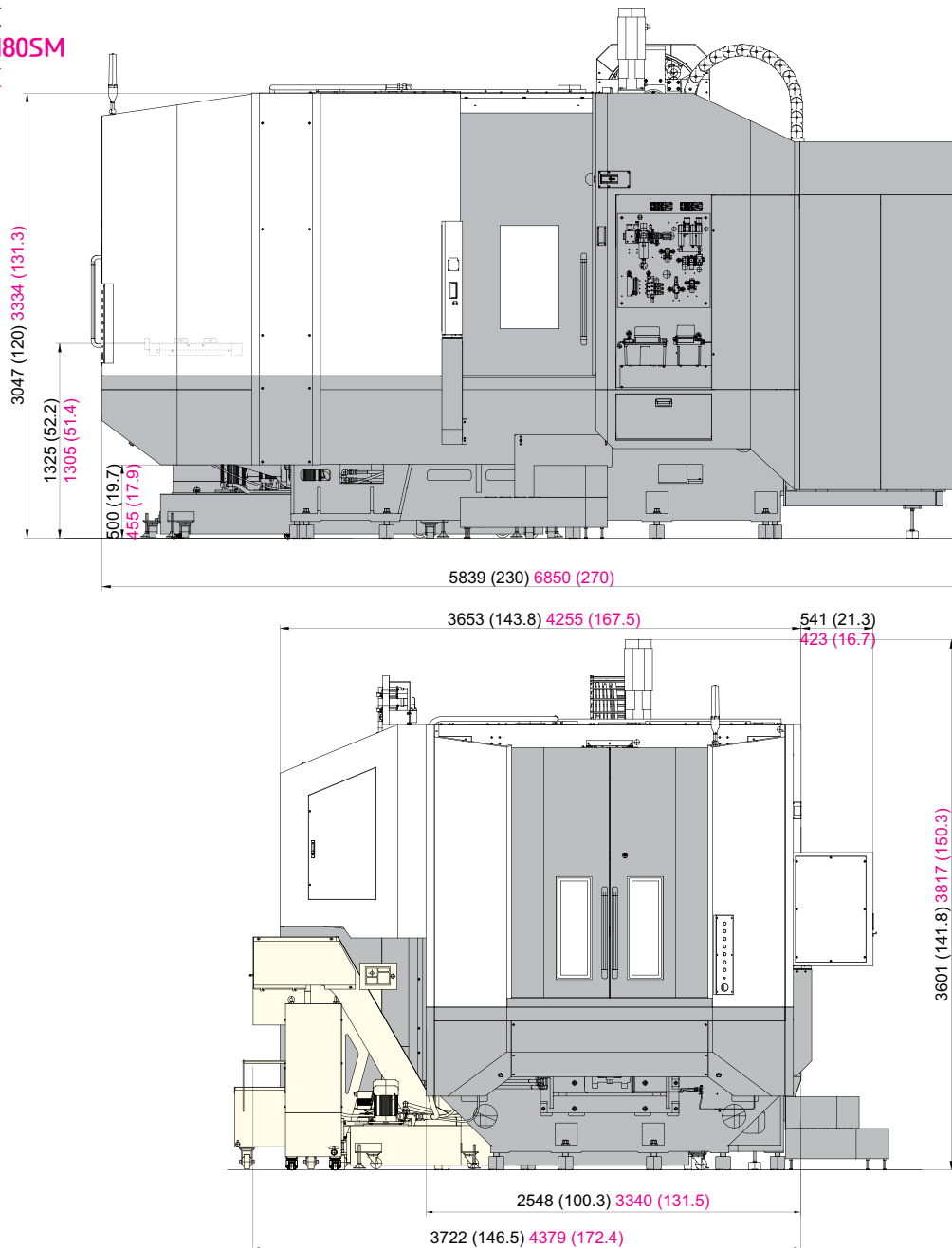

Machine length

Magazine	40EA	60EA	90EA	120EA	150EA	240EA
HH63SMAX	5,839 (230")	5,839 (230")	6,105 (240.4")	7,240 (285")	8,135 (320.3")	9,443.5 (371.8")
HH80SMAX	6,850 (270")	6,850 (270")	7,160 (281.9")	8,295 (326.6")	9,295 (365.9")	10,500 (413.4")

❖ 240 Tool : Matrix Type

SPECIFICATIONS

Transfer Range & Machining Area

unit : mm(in)

HH63S MAX HH80S MAX

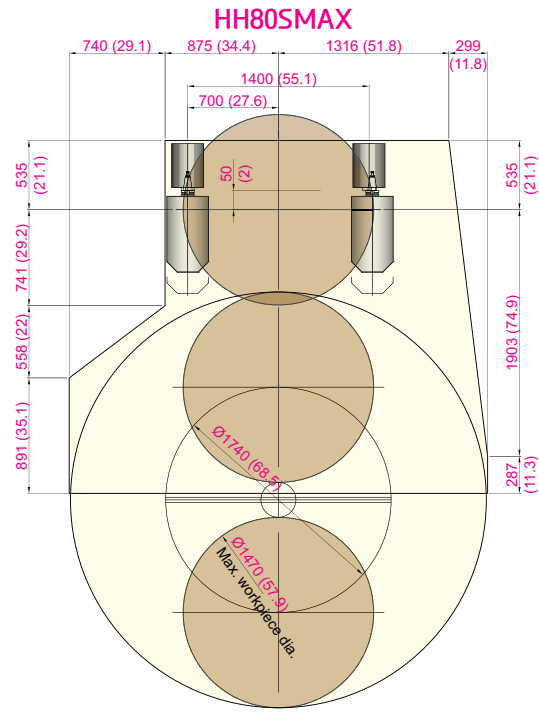
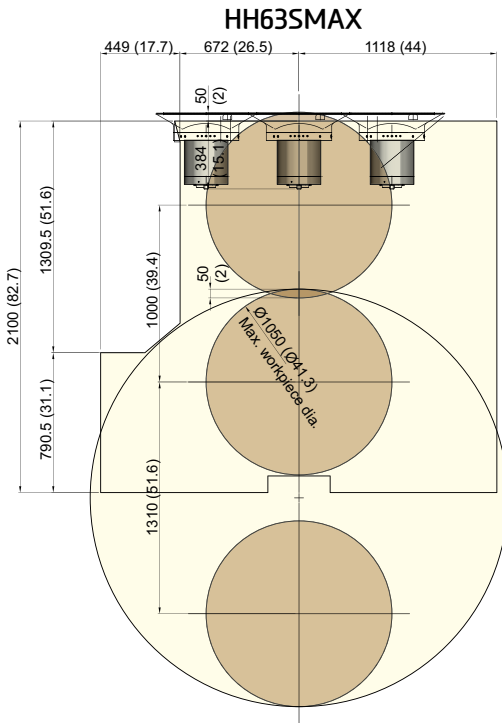
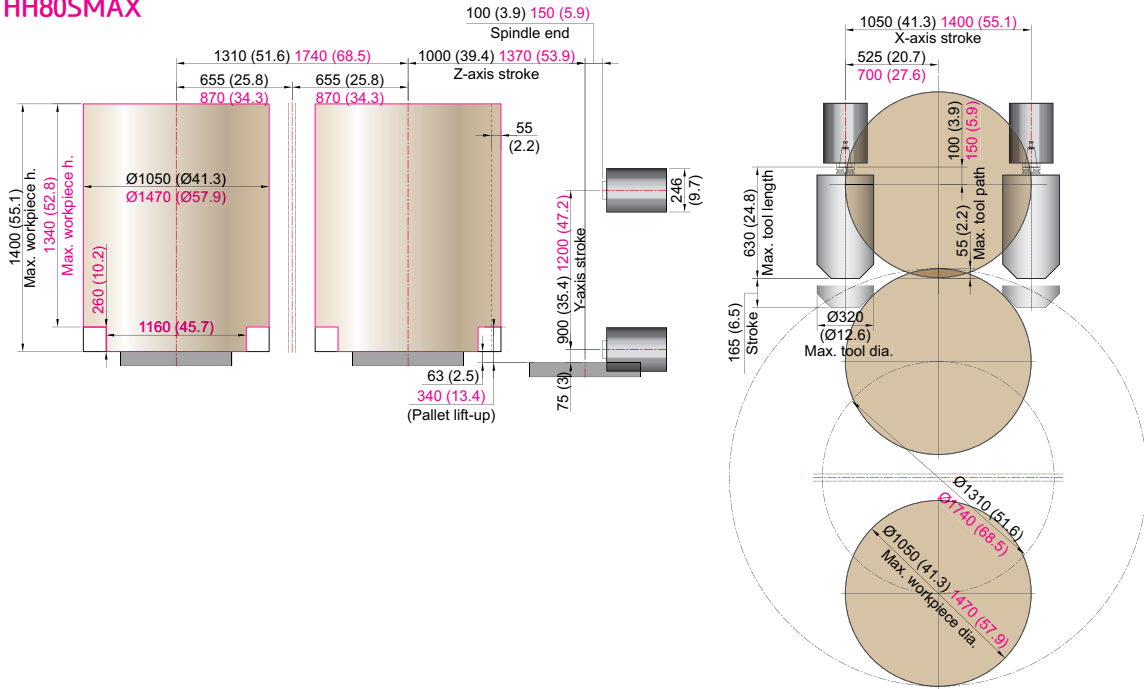

SPECIFICATIONS

Table Dimensions

unit : mm(in)

HH63SMAX
HH80SMAX

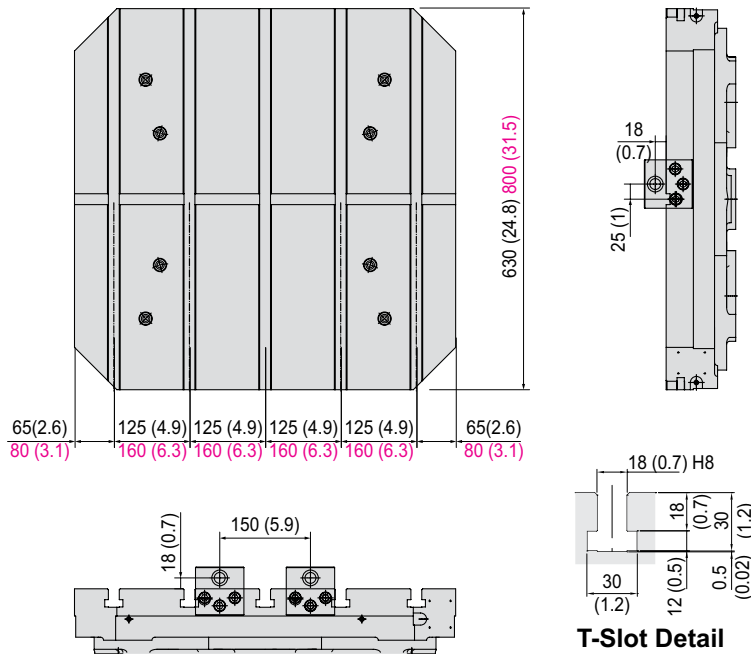
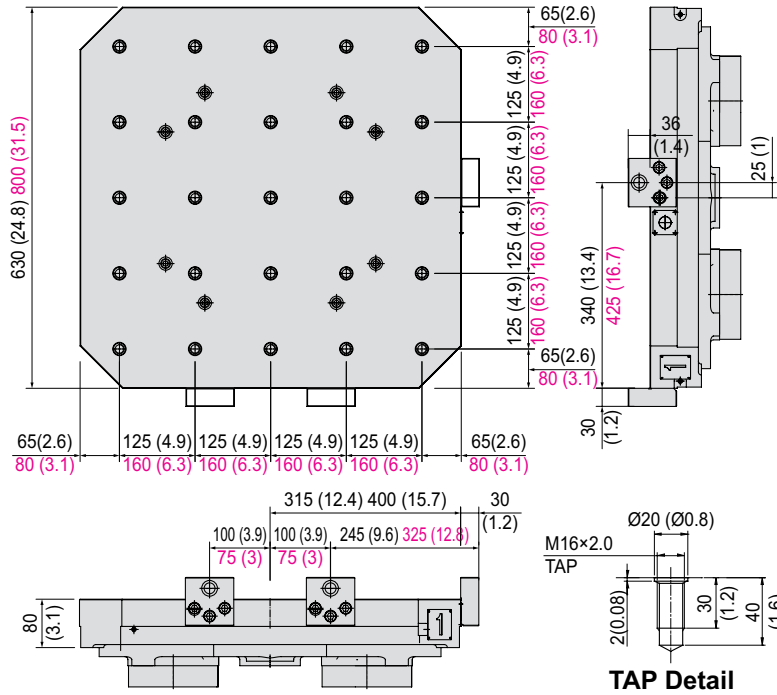

SPECIFICATIONS

Tool Shank

unit : mm(in)

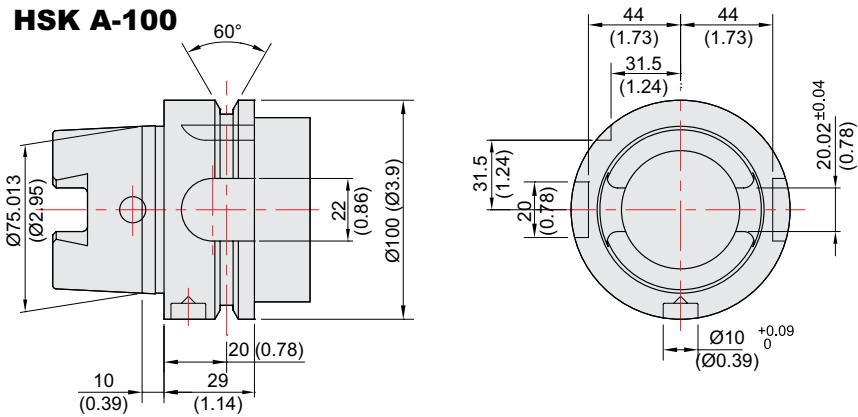
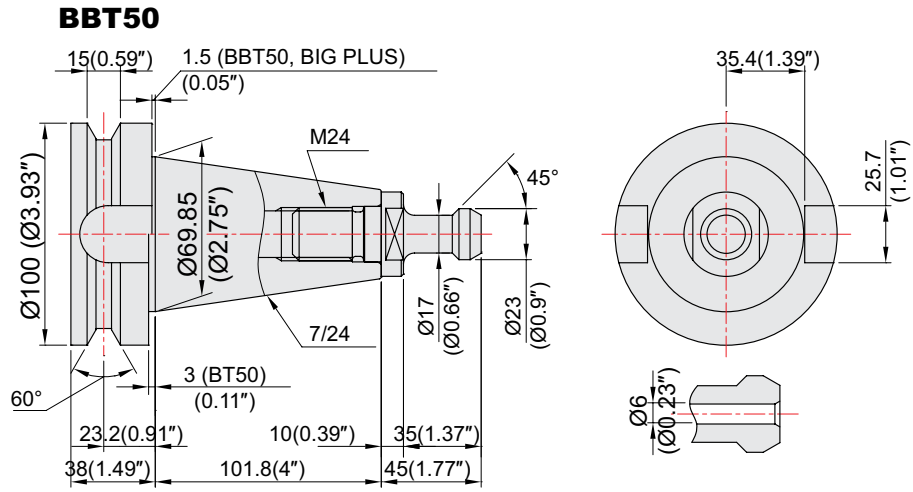

SPECIFICATIONS

Specifications

[] : Option

ITEM		HH63SMAX	HH80SMAX	
PALLET	Pallet Size (L×W)	mm(in)	2 - 630×630 (24.8"×24.8")	2 - 800×800 (31.5"×31.5")
	Maximum Load Capacity	kgf(lbf)	2 - 1,500 (3,307)	2 - 2,000 (4,409)
	Maximum Working Size	mm(in)	Ø1,050×H1,400 (Ø41.3"×H55.1")	Ø1,470×H1,600 (Ø57.9"×H63")
	Min. Indexing Angle	deg	1° [0.001°]	
SPINDLE	Spindle Taper	-	BBT50 [HSK-A100]	
	Spindle RPM	r/min	10,000 [15,000] [6,000]	
	Spindle Motor Output (Max./Cont.)	kw(HP)	45/25 (60/33.5) [37/30 (50/40)] [55/30 (74/40)]	
	Spindle Torque (Max./Cont.)	N·m(lbf·ft)	623/305 (459.5/225) [398/191 (293.6/140.9)] [807/353 (595.2/260.4)]	
	Spindle Driving Method	-	BUILT-IN	
FEED	Travel (X/Y/Z axis)	mm(in)	1,050/900/1,000 (41.3"/35.4"/39.4")	1,400/1,200/1,370 (55.1"/47.2"/53.9")
	Distance from Table Top to Sp. Center	mm(in)	75 ~ 975 (3"/38.4")	75 ~ 1,275 (3"/50.2")
	Distance from Table Center to Sp. Nose	mm(in)	100 ~ 1,100 (3.9"/43.3")	150 ~ 1,520 (5.9"/59.8")
	Rapid Traverse Rate (X/Y/Z)	m/min(ipm)	60/60/60 (2,362/2,362/2,362)	50/50/50 (1,969/1,969/1,969)
	Slide Type	-	ROLLER GUIDE	
ATC	Number of Tools	EA	40 [60, 90, 120, 150] [Matrix : Over 240]	
	Tool Shank	-	BBT50 [HSK-A100]	
	Max. Tool Dia. (W.T/W.O.)	mm(in)	Ø135/Ø320 (Ø5.3"/Ø12.6")	
	Max. Tool Length	mm(in)	630 (24.8")	
	Max. Tool Weight	kg(lb)	30 (66.1)	
	Tool Selection Method	-	FIXED ADDRESS	
	Tool Change Time	C-C	sec	4.9
APC	No. of Pallet	EA	2	
	APC Type	-	DIRECT TURN	
	Pallet Change Time (Vacant)	sec	* 12	* 16
TANK CAPACITY	Coolant Tank	ℓ (gal)	680 (179.6)	
	Lubricating Tank	ℓ (gal)	4 (1.06)	
	Hyd. Tank Unit	ℓ (gal)	45 (11.9)	
POWER SUPPLY	Air Consumption (0.5MPa)	ℓ /min(gal/min)	450 (118.9)	
	Electric Power Supply	KVA	59	57
	Thickness of Power Cable	mm ²	Over 50	
	Voltage	V/Hz	220/60 (200/50*)	
MACHINE	Floor Space (L×W)	mm(in)	3,722×5,839 (146.5"×229.9") (40 Tool)	4,379×6,850 (172.4"×269.7") (40 Tool)
	Height	mm(in)	3,601 (141.8")	3,817 (150.3")
	Weight	kg(lb)	19,000 (41,888)	27,000 (59,525)
PC	Controller	-	FANUC 31i-B Plus	

* APC changing time can vary depending on the weight of work piece.

*) Using 50Hz voltage instead of 60Hz may lower the output of motors. (excluding servo motors and inverter motors)

Specifications are subject to change without notice for improvement.

CONTROLLER

FANUC 31i-B Plus

[] : Option ☆ Needed technical consultation

Controlled axis / Display / Accuracy Compensation	
Control axis	4 axis (X, Y, Z, B)
Simultaneously controlled axis	3 axis [Max. 4 axis]
Least setting Unit	X, Y, Z axis : 0.001 mm (0.0001 inch) B axis : 1 deg [0.001] deg
Least input increment	X, Y, Z axis : 0.001 mm (0.0001 inch) B axis : 1 deg [0.001] deg
Inch / Metric conversion	G20 / G21
High response vector control	
Interlock	All axis / Each axis
Machine lock	All axis
Backlash compensation	± 0 ~ 9999 pulses (Rapid traverse / Cutting feed)
Position switch	
LCD / MDI	15" color LCD with Touch screen
Feedback	Absolute motor feedback
Stored stroke check 1	Over travel
Stored stroke check 2, 3	
Pitch error compensation	
Operation	
Automatic operation (Memory)	
MDI operation	
DNC operation	Needed DNC software / CF card
Program restart	
Wrong operation prevention	
Program check function	Dry run, Program check Z axis Machine lock, Stroke check before move
Single block	
Search function	Program Number / Sequence Number
Retraction for rigid tapping	
Manual guide i	Smart Guide i
Interpolation functions	
Nano interpolation	
Positioning	G00
Linear interpolation	G01
Cylindrical interpolation	G02, G03
Exact stop mode	Single : G09, Continuous : G61
One-way positioning	G60
Inverse-time feed	G93
Dwell	G04, 0 ~ 9999.9999 sec
Skip	G31
Reference position return	1st reference : G28 2, 3, 4 reference : G30 P2, P3, P4 Ref. position check : Z7
Thread synchronous cutting	G33
Helical interpolation	Circular + Linear interpolation 2 axis(max.)
Feed function / Acc. & Dec. control	
Rapid traverse	
Manual feed	Jog : 0~5,000mm/min (197 ipm) Manual handle : x1, x10, x100 pulses Reference position return
Cutting Feed command	Direct input F code
Feedrate override	0 ~ 200% (10% Unit)
Rapid traverse override	F0% (F1%), F25%, F50%, F100%
Override cancel	
Feed per minute	G94
Feed per revolution	G95
Look-ahead block	1,000 Block
Program input	
Tape Code	EIA / ISO
Optional block skip	9 ea
Absolute / Incremental program	G90 / G91
Program stop / end	M00, M01 / M02, M30
Maximum command unit	± 999,999.999 mm (± 99,999.9999 inch)
Plane selection	X-Y : G17 / Z-X : G18 / Y-Z : G19
Workpiece coordinate system	G52, G53, 48 pairs (G54.1 P1 ~ P48)
Manual absolute	Fixed ON
Programmable data input	G10
Sub program call	10 folds nested
Custom macro	#100~#199, #500~#599, #98000~#98499
Programmable mirror image	G51.1, G50.1

Controlled axis / Display / Accuracy Compensation	
Polar coordinate command	G15, G16
Do not look ahead function	G4.1
Including Chamfering / Corner R	
Canned cycle	G73, G74, G76, G80 ~ G89
Coordinate rotation	G68, G69
Scaling	G50, G51
Auxiliary function / Spindle speed function	
Auxiliary function	M 4 digit
Level-up M Code	Multi / By-Pass
Spindle speed command	S 5 digit , Binary output
Spindle override	50% ~ 120% (10% Unit)
Spindle orientation	M19
FSSB high speed rigid tapping	
Tool function / Tool compensation	
Tool function	Max. T 8 digit
Tool life management	256 pairs ☆
Tool offset pairs	400 pairs
Tool nose radius compensation	G40, G41, G42
Tool nose length compensation	G43, G44, G49
Tool offset memory C	Tool length, diameter, abrasion (Length/Dia.)
Tool length measurement	Z axis Input C
Editing function	
Part program storage size	10240m (4MB)
No. of registerable programs	1,000 ea
Program protect	
Background editing	
Extended part program editing	
Memory card program edit	Copy, move and change of file program
Protection of data at 8 levels	
Data input / output & Interface	
I/O interface	Memory card, USB memory interface Embedded Ethernet interface
Screen hard copy	
External message	
External key input	
External workpiece number search	
Automatic data backup	
Setting, display and diagnosis	
Self-diagnosis function	
History display	Alarm & Operator message & Operation
Run hour / Parts count display	
Maintenance information	
Actual cutting feedrate display	
Display of spindle speed / T code	
Graphic display	
Operating monitor screen	
Power consumption monitoring	Spindle & Servo
Multi language display	Support 25 languages
Display language switching	Selection of 5 optional Languages
LCD Screen Saver	Screen saver
Macro Excutor	Custom software 8MB (WIA Screen)☆
Processing select	Speed/ridigity setting
Option	
Fast ethernet	Needed option board
Data server	Needed option board (1GB, 2G, 4GB)
Sub Spindle control	☆
Polar coordinate interpolation	G12.1, G13.1
Cylindrical interpolation	G07.1
Manual handle feed	2/3 units
Tool offset number	Max. 2,000 pair
Program storage capacity	~32MByte
Program registration number	Max. 4,000 ea
Additional work coordinate	300 pair (G54.1 P1 ~ P300)

Figures in inch are converted from metric values.

The FANUC controller specifications are subject to change based on the policy of company CNC supplying.

SGWIA ECO SYSTEM

MQL (Minimal Quantity Lubrication)

The goal of this system is to spray only the amount of lubricant required to prevent heat and chip build up at the cutting tool or work piece face.

Example of Machining Center Application

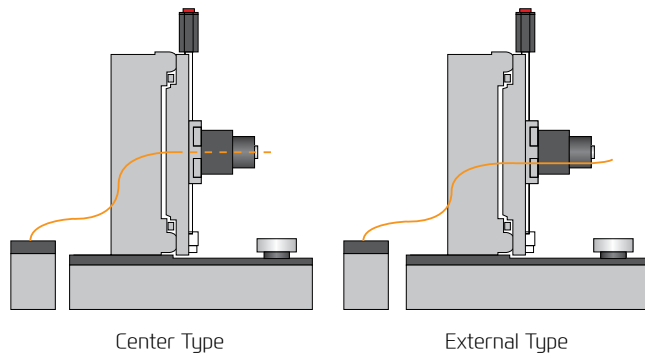

Example of Etc.

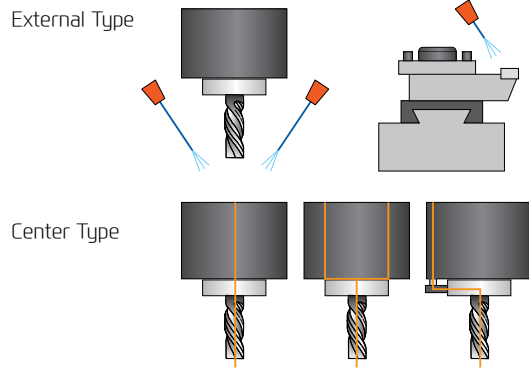

Oil Skimmer

An oil skimmer can increase coolant and tool life by removing tramp oil contaminants.



Mist Collector

Mist Collector reduces the amount of smoke and oil mist in the air. This helps build a safe and comfortable working environment and improve durability.

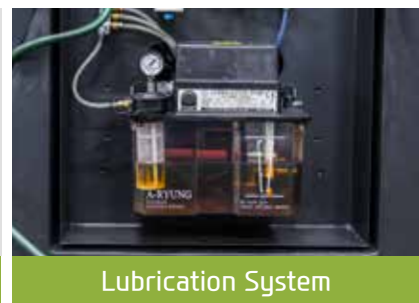

Lubrication System

By applying lubricant only when the machines axis are moving lubrication consumption is reduced by compared to standard systems.

SGWIA ENERGY SAVING

HW-ESS (SGWIA Energy Saving System)

SGWIA Machine tool provides the optimum power saving function that can easily save energy with an intuitive user interface.



1. **Machine-ready power saving function** : Put all servo motors and other motors into sleep mode when no control or operation is done for a set time
2. **Work light auto-off function** : The work light is turned off automatically when no control or operation is done for a set time
3. **Chip conveyor auto power saving** : Operation/non operation time (timer) can be set to save energy
4. **Auto Power-off** : Auto power off after ending the an operation after a period of time
5. **Eco function** : Machine ready sleep mode can be activated/de-activated from the controller panel
6. **Power consumption monitor** : Real time power consumption can be monitored through the OP screen